

# GEIS

## Critical Power Transfer System

GEIS Electrical Protection

Safer Smarter Greener



## About GEIS

GEIS was established in 2019 following the spin-off of several businesses and assets that ABB had acquired from GE on July 1, 2018, including 3 manufacturing centers, Warehousing & Trading business at FTZ, China Technology Center.

- Components: Full range of circuit breakers up to 40.5kV: Medium voltage vacuum circuit breakers, LV circuit breakers: ACB, MCCB, MCB, RCD, RCBO: Control components.
- Equipment: MV switchgear (Air insulation and Gas Insulation Technology), LV switchgear, switchboard.
- Medium voltage distribution transformer.
- Medium voltage ATS system (Paralleling Switchgear).

After the separation, all the above product lines were rebranded as AEG for selected markets and GEIS for global markets. Moreover, GEIS has expanded its technological portfolio to include medium-voltage controls such as VFDs and soft starters, as well as ATS systems and EV chargers.



## Quality is Built-in

### Where Technology Meets Manufacturing Excellence for Customers

- Since 2000, we have been specializing in localizing world-class products and manufacturing technologies, developing strong expertise and a highly capable team.
- Vertical integrated Shanghai Manufacturing Center brought key manufacturing processes into a 75,000 m<sup>2</sup> facility, enabling high-quality, high-efficiency production and fostering innovation. A dedicated R&D team committed to developing products that meet global standards and serve diverse applications.
- Global expansion: GEIS's first Thailand facility makes it easier to serve customers worldwide.



### GEIS deliver complete range of products for the evolving electrification needs:



**SecoVac VCB**



**M-PACT Plus ACB**



**Elfa Series MCB/RCBO**



**SolidDrive MV VFD**



**SecoGear MV Switchgear**



**RMU Gas Insulated Switchgear**



**WaveCast Transformer**



**MLS LV Switchgear**

# Critical Power Transfer System

## Catalogue

### A

#### MAST MV Automatic Transfer Switch System

### B

#### MEAT LV Automatic Transfer Switch System

- B.1 E2 Automatic Power Transfer System
- B.1 E3 Automatic Power Transfer System
- B.1 Adapter
- B.1 Size
- B.4 Ordering information

### C

#### MARS Automatic Transfer Switch

- C.1 AT50 PC-level Bypass Automatic Transfer Switch AT30
- C.1 Industrial PC-level Automatic Transfer Switch AT20
- C.1 Construction PC-level Automatic Transfer Switch AT10
- C.1 Terminal PC-level Automatic Transfer Switch AT10B
- C.4 CB-level Automatic Transfer Switch

# MAST MV Automatic Transfer Switch System

## Overview

Medium-voltage automatic transfer switch system is mainly used in data centers, highways, medical facilities, banking systems, airports, telecommunications, semiconductors and other important load grid. When the utility power failure or outage occurs, it will switch to the auxiliary power, such as diesel generator through the ATS system to ensure the normal operation of important loads. The MAST medium-voltage ATS system has the advantages of high transfer reliability, short transfer time, and simple structure. The dual interlocking functions of electrical and mechanical ensure the safety of power supply. The MAST-LM medium-voltage automatic sequential switching system can automatically disconnect or connect the medium-voltage feed lines in a pre-set sequence during the transition between the utility power and the backup power source, ensuring the reliability of important power supply circuits.



## Product

- Multiple design schemes, integrated and split-type, to meet the needs of different customers.
- The minimum width of a single cabinet is 650mm, the overall width of the split-type is less than 2000mm, and the overall width of the integrated type is less than 1500mm, saving space.
- It has both power transfer and load sequential switching functions, with excellent performance.
- The transfer control unit can provide protection for the lines simultaneously, which is economical and efficient.
- Multiple safeguards including mechanical interlocking, electrical interlocking, and logical interlocking ensure safety and reliability.
- It has passed the integrated type test and is certified by the authoritative institution Xi'an High Voltage Apparatus Research Institute

## Standards

<b>GB/T 3906-2006</b>	Alternating-current metal-enclosed switchgear and controlgear for rated voltages above 3.6kV and up to and including 40.5kV
<b>GB/T 11022-2011</b>	Common specifications for high-voltage switchgear and controlgear standards
<b>GB/T 1984-2014</b>	High-voltage alternating-current disconnectors and earthing switches
<b>GB/T 1985-2014</b>	Common specifications for high-voltage switchgear and controlgear standards
<b>IEC 60694-2002</b>	AC metal-enclosed switchgear and controlgear for rated voltages above 1 kV and up to and including 52kV
<b>IEC 62271-200-2011</b>	Alternating current circuit-breakers
<b>IEC 62271-100-2012</b>	Alternating current disconnectors and earthing switches
<b>IEC 62271-102-2012</b>	Alternating current disconnectors and earthing switches

# MAST MV Automatic Transfer Switch System

## Ambient Conditions

### Temperature

- 40°C ~+55°C

### Humidity

- Maximum daily relative average humidity ≤95%
- Maximum monthly relative average humidity ≤90%

### Seismic intensity

- No more than 9 degree

### Altitude

- No more than 2,000m

### Other

- Translation: The use site should be free of water droplets, flammable and explosive hazards, corrosive chemical gases, severe contamination, and intense vibrations.
- For special requirements under non-standard operating conditions, the user needs to consult with the manufacturer and reach a mutual agreement.

## Model Description

MAST	-12	/630	-25	C
<b>Product range</b>	<b>Rated Voltage</b>	<b>Rated current</b>	<b>Thermal Stability</b>	<b>Type of construction</b>
MAST Automatic dual power conversion system	12-12kV	630-630A	25-25kA	C: Integrated
	15-15kV	1250-1250A	31.5-31.5kA	S: Split
	17.5-17.5kV	1600-1600A	40-40kA	TB: bypass type
	24-24kV	2000-2000A		
		2500-2500A		

MAST-LM	-L	D1
<b>Product Series</b>	<b>Configuration</b>	<b>Control Power Configuration</b>
MAST-LM Medium-voltage Automatic Stage Switching System	L-- Main control pan	D1-DC110V
	R-- Remote control pan	D2-DC220V

Note: Integrated rated current are 630A, 1250A; Split type rated current is 2500A, please contact us if current is upper.

## Main Performance Parameters

item	Units	Parameters
Rated voltage	kV	12, 15, 17.5, 24
Rated powerfrequency withstand voltage (1 min)	kV	42
Rated lightning impulse withstand voltage	kV	75
Rated current	A	630/1250/1600/2000/2500
Rated short circuit breaking current	kV	25/31.5/40
Rated short-time withstand current (4s)	kV	25/31.5/40
Rated peak withstand current	kV	63/80/125
Internal arc protection class		IAC A FLR 31.5kA/1s
Conversion mode of operation		Cold receptor/hot receptor

## MAST MV Automatic Transfer Switch System

### Main Technology

#### SecoVac series medium voltage circuit breaker/MAST integrated transfer circuit breaker

The MAST system utilizes the SecoVac series vacuum circuit breaker or the MAST integrated transfer circuit breaker, which represent the perfect combination of AEG's reliable vacuum arc-extinguishing chamber and manufacturing technology, as well as advanced actuator development, design, and production technology.

The MAST split-type actuator unit consists of two circuit breakers placed separately in independent compartments, while the integrated actuator unit is composed of a single integrated transfer circuit breaker with an upper and lower structure. Both are equipped with fixed mechanical interlocks and electrical interlocks to ensure that only one of the two incoming circuits can be in a connected state at any time.

- High performance AVI arc-extinguishing chamber with rated short circuit breaking current up to 100 times
- Modular spring mechanism with mechanical life of up to 60,000 times
- The ASP type solid-insulated pole offers superior performance, is recyclable, and is more environmentally friendly
- The electroplating process with strong corrosion resistance ensures that the equipment is suitable for various environments.

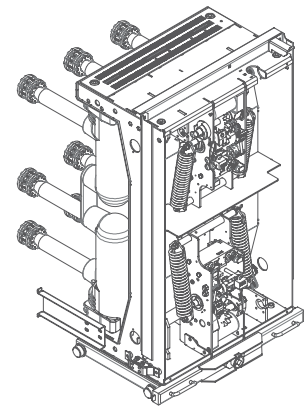

#### MAST Power Transfer Intelligent Controller

The MAST power transfer intelligent controller has flexible software and hardware configurations, capable of collecting multiple sets of current and voltage signals, position signals of circuit breakers and trolleys, as well as control output signals, fully meeting the requirements for automatic transfer of medium-voltage dual power sources and step-by-step load switching functions.

- Transfer function, load switching function
- Logic programming function
- Event recording with time stamp
- Two-stage time-bound load shedding
- Current protection and voltage protection functions
- Accident transfer caused by low voltage, high and low voltage side tripping, switch mis-tripping, and other switching quantities
- PT break alarm
- Multiple blocking functions, such as protection blocking and switch one-time blocking
- Measurement and communication functions are available with selectable communication interfaces such as Ethernet cable, fiber optic, and RS485, with various communication protocols such as Modbus, 103, and 104 available for choice.
- Circuit breaker status monitoring function
- Panel LED status indication

## MAST MV Automatic Transfer Switch System

### Latching Protection

The MAST medium-voltage dual power transfer system has a complete interlocking protection mechanism, ensuring safe operation for users through interlocking between circuit breakers, five-prevention interlocking of the cabinet, and internal and external program locking methods.

### Mechanical Interlocking

- By mechanically linking the closing and opening mechanisms of the two circuit breakers with a cross-connecting rod, it ensures that the two vacuum circuit breakers for the mains power supply and the backup power supply cannot be closed simultaneously when in the working position.
- An electric chassis car scheme can be selected. By mechanically interlocking the chassis car, the vacuum circuit breaker is controlled to be in the working / test position, ensuring that the two vacuum circuit breakers cannot be in the working position at the same time, achieving a cold backup of the system.

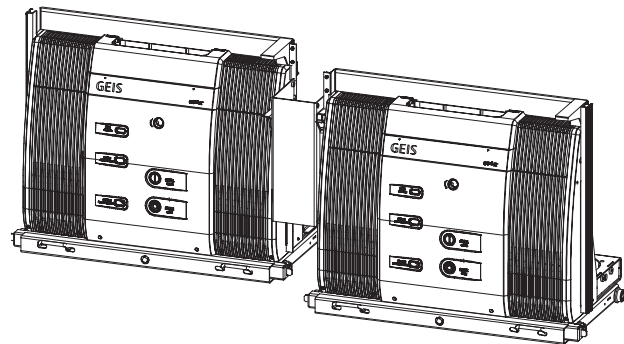
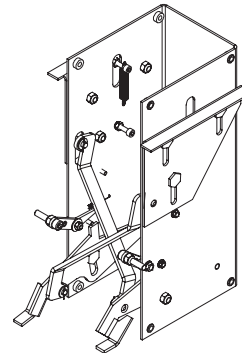

### Electrical Interlocking

- The closing and opening signals of the two vacuum circuit breakers are interlocked through external secondary wiring. This ensures that when one vacuum circuit breaker is closed, the other vacuum circuit breaker cannot be closed.
- Through the internal program lock of the ATS controller, input circuit breaker status signals, after the internal program is locked, it is not possible to output two closing signals simultaneously.

### Short-circuit protection block

If the incoming line protection device trips, it will immediately lock, preventing system transfer and avoiding the expansion of the fault area and irreversible damage to the equipment.

### PT break block

When the system detects a broken line in the PT circuit, the main circuit and the detection circuit will become out of sync. The system will immediately lock the transfer action to prevent faultless transfer.

# MAST MV Automatic Transfer Switch System

## Control System - Transfer Operation Mode

The MAST control system includes a power management terminal and a terminal management system, which can achieve three control modes of manual, automatic, and remote according to user needs. Under the automatic mode, it supports three types of conversion: open circuit conversion, delayed conversion, and user-defined conversion. It also realizes automatic operation, self-investment and self-recovery, and self-investment without self-recovery, meeting the application requirements for power conversion and load switching.

### Automatic Transfer mode

In the automatic conversion mode, the system determines whether the power supply is normal based on the pre-set power detection conditions. When a power supply fails, it automatically switches according to the set working mode.

#### Auto transfer & retransfer

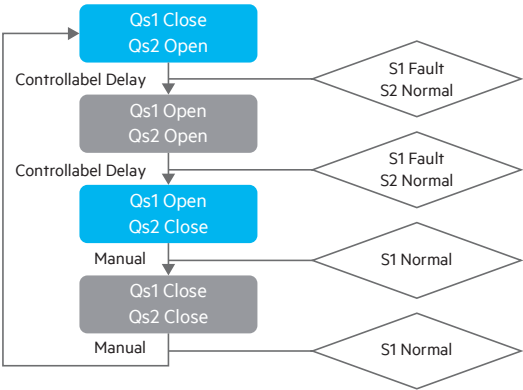

#### Auto transfer & not retransfer

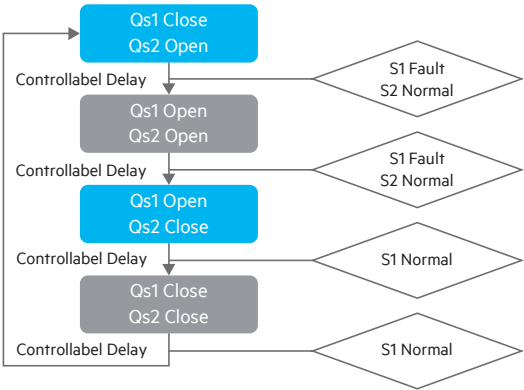

### Cold/hot Standby Transfer

In accordance with the operational specifications of the State Grid, the process simulates manual operation, and during the automatic conversion, it safely isolates the two power sources.

- Cold Standby Transfer Process**

During normal operation, the mains power supply is working, and the backup power supply is in the maintenance isolation position, with the circuit breaker VCB2 open. When a fault occurs in the main power supply, after a delay, the main power supply circuit breaker VCB1 opens and exits the working position. The backup power supply automatically enters the working position, the circuit breaker VCB2 closes, completing the switchover.

Note: Cold standby need to choose the electric handcart type circuit breaker

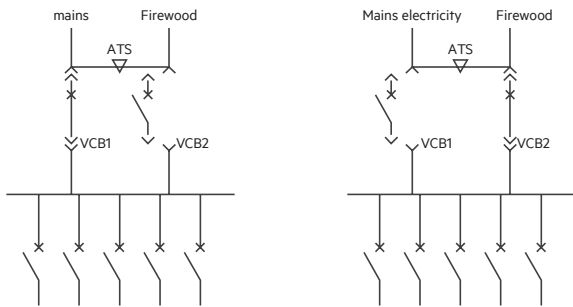

- Hot Standby Transfer Process**

During normal operation, the primary power supply is active, and the backup power supply is in the working position with the circuit breaker VCB2 open. After a fault occurs in the primary power supply, following a delay, the primary power supply circuit breaker VCB1 opens. The backup power supply circuit breaker VCB2 closes, completing the switchover.

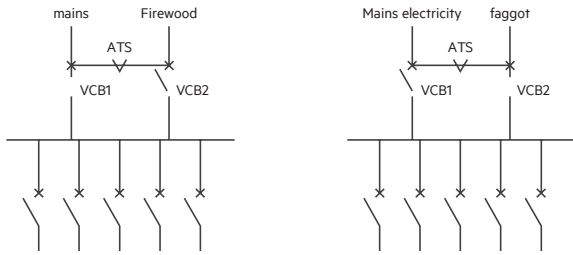

## MAST MV Automatic Transfer Switch System

### Control System - Staged Switching

#### Feature

The main function of the staged switching control is to prevent multiple transformers from experiencing a strong inrush current or startup current when they are put into operation or disconnected under load simultaneously. This can cause a significant impact on the entire power supply system and may lead to tripping of the incoming line or misoperation of the upstream substation

- Generator start/stop signal control
- Load control sequential switching
- In line with generator usage habits
- Ensure the continuous power supply of important loads
- Reduce load and busbar current fluctuations
- Prevent impulse current from causing protective action
- Prevents unlining caused by fluctuations in voltage



#### Monitoring and control

The MAST staged switching control system can monitor and control both the mains power supply lines and the backup power supply lines, while also controlling the positions of all feeder circuit breakers, the positions of the trolleys, and each individual circuit breaker. It can also simultaneously monitor the voltage and frequency of the busbar sections.

#### Operation procedure

##### Auxiliary Generator Power Supply

After the mains power fails, based on the status of the diesel generator, the corresponding load break circuit breakers are tripped in a pre-set sequence. After the load is cut off, all mains power supply circuit breakers are tripped, and then the backup power supply circuit breaker (diesel generator) is closed. After the backup power supply (diesel generator) is closed, the load break circuit breakers are phased in with a delay according to the pre-set sequence, achieving staged load switching.

##### The Mains Power Supply

After the mains power is restored, after tripping the corresponding load break circuit breakers in the preset sequence, the backup power supply (diesel generator) is cut off, and then the mains power supply circuit breakers are closed. After the mains power supply is closed, the

# MAST MV Automatic Transfer Switch System

## Typical Application Solution

### Main to Main Transfer

Common mains S1 power supply failure automatically disconnect circuit breaker VCB1. Put in VCB2, powered by auxiliary S2.

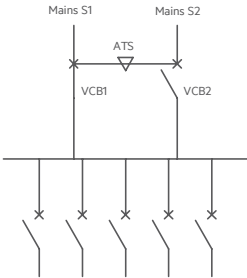

### Main to chip-power transfer

When the mains power supply fails, the circuit breaker VCB1 is automatically tripped, and the generator is started. After a period of time, the voltage magnitude and frequency of the generator circuit are checked. Once the set values are met, VCB2 is closed. The system is then powered by the generator.

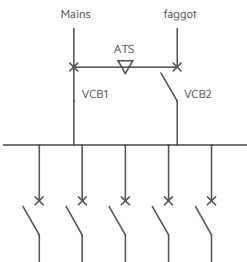

### Main to main to firewood transfer

When the mains power supply S1 fails, automatically disconnect the circuit breaker VCB11, put it into the busbar, and take the full load from the other mains.

When both medium-voltage mains power supplies fail, the mains circuit breakers are tripped, the generator is started, and at the same time, the corresponding load break circuit breakers are tripped in a pre-set sequence. By inspection, the voltage magnitude and frequency of the generator circuit are checked. Once the set values are met, the generator power supply circuit breakers VCB12 and VCB22 are closed, and then the load break circuit breakers are phased in one by one according to the pre-set sequence with a delay.

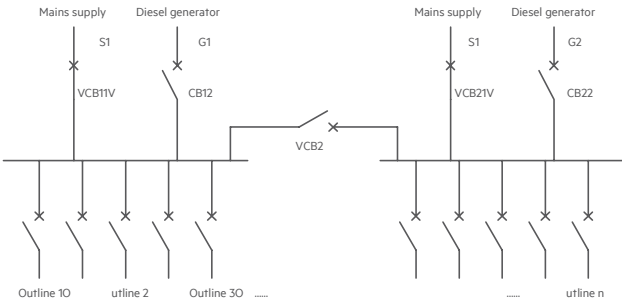

# MAST MV Automatic Transfer Switch System

## Basic Type

When installing on-site, appropriate space should be left between the cabinet and the surrounding walls to serve as a maintenance passage. The attached figure shows a reference plan for the layout of the distribution room. It is recommended that the effective distance in front of the cabinet be 1200-2500mm, the effective distance from the back of the cabinet to the wall be 1000mm, and the effective distance on both sides be 1200mm. The construction of the ground foundation for the installation of the switchgear should comply with the regulations for the connection between the cabinet and the channel steel in the “Technical Specifications for Construction and Acceptance of Electric Power Construction” to ensure the quality of the installation. The technical requirements for the installation of the foundation channel steel structure allow for an error of no more than 1mm per meter, with a total length error of  $\pm 3$ mm.

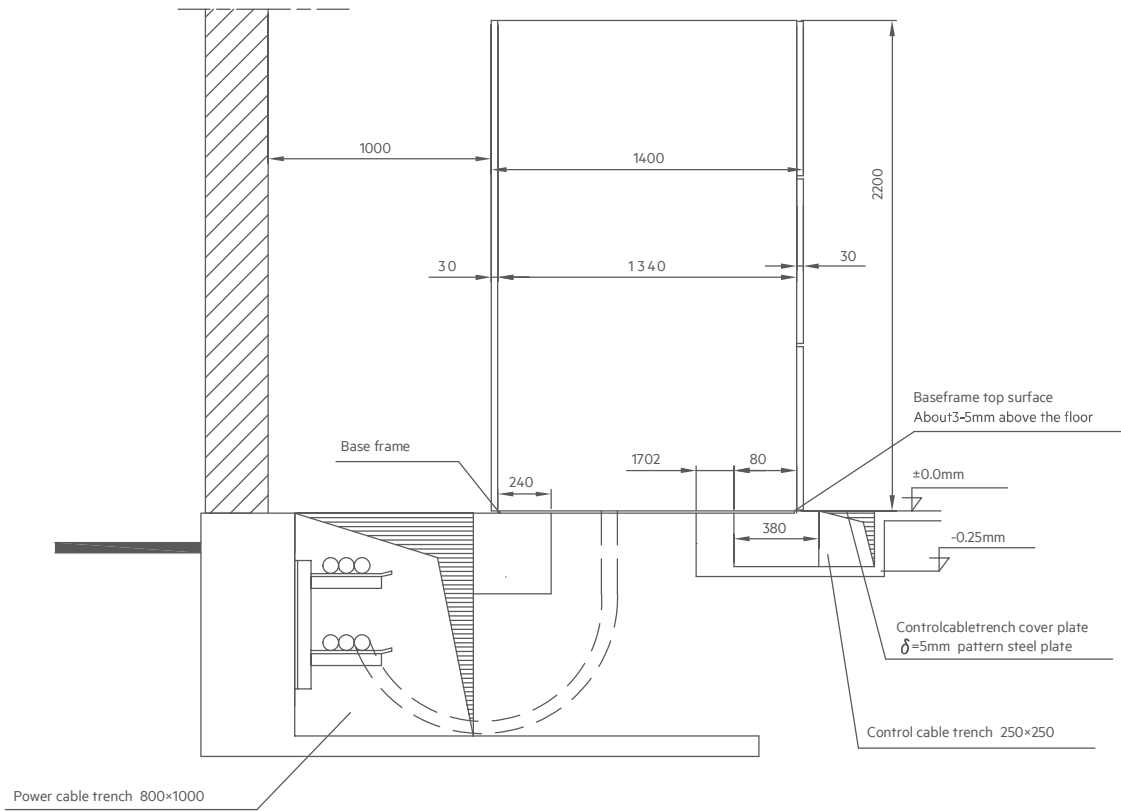

Mode	specification	Units	Width (w)	Depth (d)	Hight (h)
MAST-S	Rated current 1250A and below,heat stable current 31.5kA and below	mm	1950/2400	1400/1600	2200
	Rated current 1250A,heat stabilized current 40kA	mm	2400	1400/1600	2200
	Rated current 1600A, heat stable current 40kA and below	mm	2400	1400/1600	2200
	Rated current 2000 or2500A, heat stabilized current 40kA and below	mm	3000	1400/1600	2200
MAST-TB	Rated current 1250A and below, heat stable current 31.5kA and below	mm	2400	1800	2200
MAST-LM		mm	800	600	2200

# MEAT LV Automatic Transfer Switch System

## Product

GEIS has always been committed to providing customers with the most advanced and GEIS has been dedicated to providing customers with the most advanced and reliable power distribution protection. From the mass production of air circuit breakers in Neumünster, Germany, in 1947, to the subsequent ME series, each series has become a classic product of low-voltage circuit breakers at that time. Based on the successful experience of the ME air circuit breakers, GEIS continuously introduces new products and technologies. The circuit breakers feature the most advanced structures and tripping mechanisms, offering customers comprehensive and optimal solutions.

The MEAT low-voltage automatic transfer switch system monitors the main power supply for undervoltage, overvoltage, and phase loss, while also monitoring whether the backup voltage is normal. If any phase in the main power supply circuit experiences an abnormality, the controller can automatically issue commands to the ME air circuit breaker according to the preset program, completing the power transfer automatically.

The MEAT automatic transfer switch system can be widely applied to occasions with high demands for continuous power supply, such as power plants, petrochemical industries, data centers, government public buildings, institutions, hospitals, schools, and large commercial complexes.

The MEAT automatic transfer switch system integrates control and protection, and works in conjunction with interlocking mechanisms. The entire system has passed the CCC product certification.



# MEAT LV Automatic Transfer Switch System

## Transfer Solution

The MEAT controller utilizes an advanced microprocessor unit and, combined with applications in various scenarios, has multiple preset working programs. Users can adjust the settings on-site according to the operating procedures based on their actual needs.

### MEAT automatic transfer switch system, there are E2, E3, E3S3 three transfer mode:

- MEAT automatic transfer switch system, there are E2, E3, E3S3 three transfer mode:

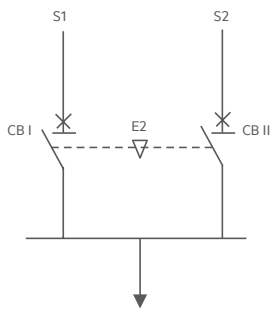

- The E3 controller combines three ME air circuit breakers, serving as a power supply switching solution that includes a bus-tie circuit breaker for two power sources.

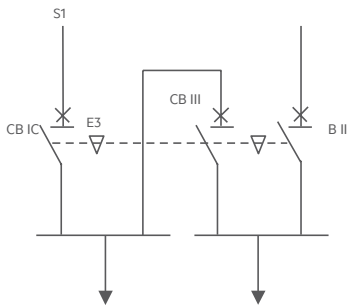

- The E3S3 controller combines three ME air circuit breakers, serving as a switching solution for three power sources supplying the same downstream load.

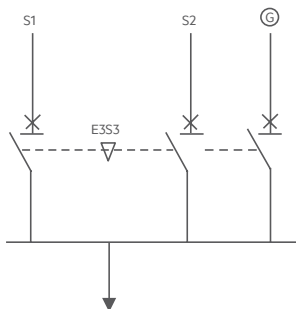

MEAT Universal Scheme		
Controller type	E2	E3
Rated voltage	AC230V	AC230V
Rated frequency	50Hz	50Hz
Auxiliary power supply	DC24V	DC24V
Detection power supply	S1/S2 (L-N)	S1/S2 (L-N)
Undervoltage setting (L-N)	150-218V	150-218V
Overtoltage setting (L-N)	242-300V	242-300V
Throw oneself in and restore oneself	■	■
One's own self will not recover	■	■
Generator starts	■	-
Busbar function	-	■
Manually operated	■	■
Remote operation	■	■
Fire linkage	■	■
Communication function	■	■
Communication protocol	Modbus	Modbus

# MEAT LV Automatic Transfer Switch System

## E2 Automatic Power Transfer System

### E2 Automatic Power Transfer Solution

The E2 controller can monitor the main power supply for under-voltage, over-voltage, and phase loss, while also monitoring whether the backup voltage is normal. If any phase in the main power supply circuit encounters an abnormality, the controller can automatically issue commands to the ME air circuit breaker according to the preset program, automatically switching to the backup power supply. The controller can be set to operate in modes of self-starting and self-recovery.

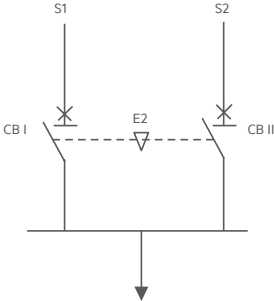

### E2 applicable type

- Mains - Mains, which controls the conversion between two mains
- Mains - generator that controls the conversion between mains and generators

### E2 Automatic Operating Mode

In automatic operation mode, the E2 controller can perform real-time sampling of the phase voltage effective values of the two power sources. The control circuit processes the sampled data and displays the status of the two power sources in real-time on the panel. After voltage effective value and phase loss detection, the control circuit calculates it against the overvoltage and undervoltage values set by the user. When an abnormality occurs in any phase of the power supply voltage, the system automatically makes a power failure judgment, and the corresponding normal power supply indicator light goes out. Depending on the user-set working mode and parameters, the controller carries out the corresponding delay. During the delay, the indicator light for the current power supply circuit breaker flashes. After the delay ends, the controller drives the circuit breaker to perform the appropriate make or break operations.

### E2 automatic mode, self - casting self - recovery

The MEAT series automatic transfer switch system E2 controller, in automatic mode (auto-throw and auto-return), has two modes of operation:

#### Mains-Mains

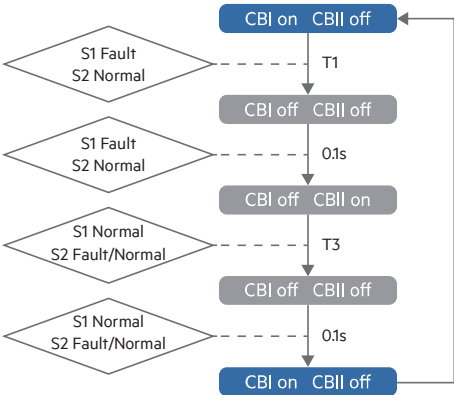

#### Mains-Generator

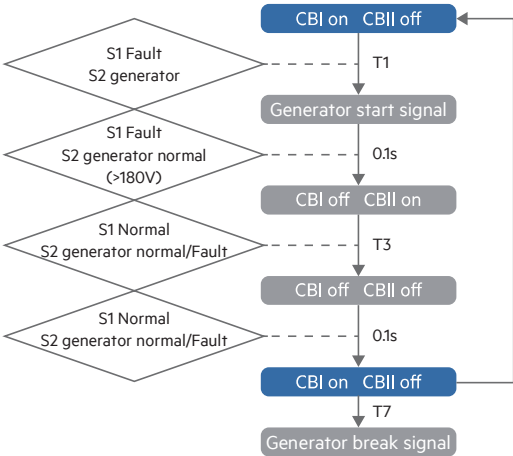

Note: S1 - Main power supply, S2 - Backup power supply; T1, T3, T7 are the delay times, with a delay range of 0 to 480 seconds.

# MEAT LV Automatic Transfer Switch System

## E2 Automatic Power Transfer System

### E2 Automatic mode Self-feed non-self-restart market power - mains power

MEAT series automatic power conversion System E2 controller, in the automatic mode (self-feed no self-recovery), the mains - mains has two working modes:

**mains - mains, self-feed no self-recovery mode 1:**

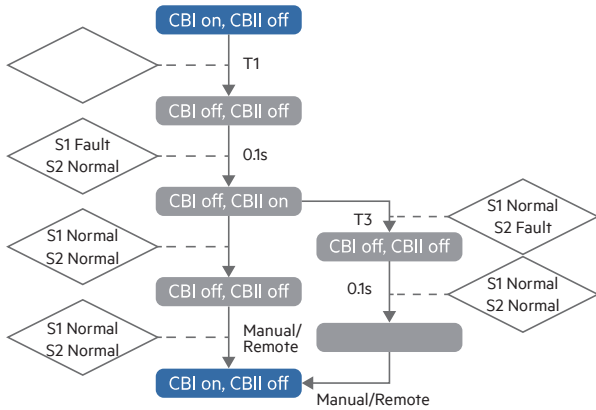

**Mains - Mains, self-feed no self-recovery mode 2:**

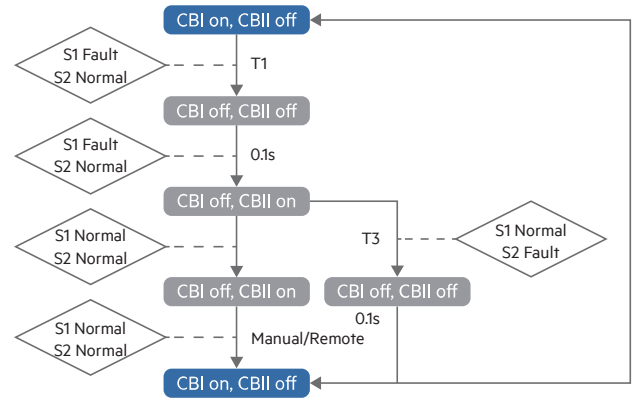

### E2 Automatic mode self-feed non-self-restart market power - generator

MEAT Series Automatic Power Conversion System E2 controller, in automatic mode (self-feed no self-recovery), the mains-generator has two modes of operation:

**mains - generator, self-feed no self-recovery mode 1:**

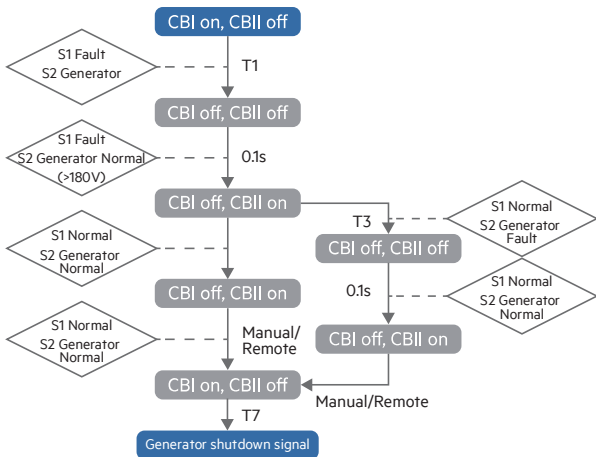

**Mains - generator, self casting non self restoring mode 2:**

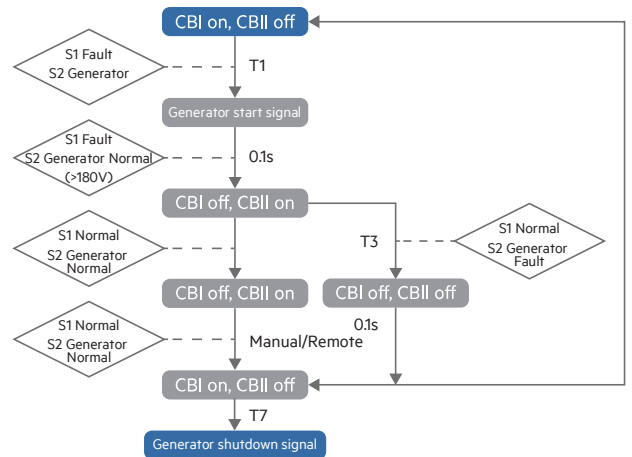

Note: S1- common power supply, S2- standby power supply; T1, T3, T7 is the delay time, the delay range is 0~480s

## MEAT LV Automatic Transfer Switch System

### E2 Automatic Power Transfer System

#### Remote operation mode

In the automatic mode, the E2 controller can be converted to the remote operation mode, and the user can access the three terminals and the commonend respectively with no source lock contact to achieve remote control:

- Remote I power supply
- Remote II power supply
- Remote switching (dual switching)



#### Communication operation mode

The E2 controller, equipped with communication features for the user, not only enables remote control operations but also allows for reading the parameters collected by the power supply system. In the event of a fault, it can retrieve fault records.

- Communication protocol: MODBUS-RTU
- Communication interface: RS485

#### Fire operation mode

In emergency situations, users can connect to the fire-fighting linkage terminals of the E2 controller without an external power source, through a self-locking contact, to perform fire-fighting operations and cut off all power supplies.

- Fire linkage is the highest priority for all operating instructions

#### Manual working mode

The humanized design of the E2 controller allows for easy installation on the cabinet door, enabling manual control mode locally. By operating different buttons on the control panel, direct priority switching can be performed:

- Switch button, switch on CBI, disconnect CBII
- Switch on key to switch on CBII and disconnect CBI
- Break key to disconnect CBI and CBII

Under the above 3 priority operating procedures, other working modes are invalid

# MEAT LV Automatic Transfer Switch System

## E3 Low Voltage Automatic Transfer Switch System

### E3 power transfer scheme

The E3 controller can monitor the main power supply for under voltage, over voltage, and phase loss, while also monitoring whether the backup voltage is normal. If any phase in the dual power supply circuit experiences an abnormality, the controller can automatically disconnect the main circuit breaker of the faulty power supply line according to the preset program. After a preset time delay, the ME circuit breaker located at the bus tie position will close, ensuring continuous power supply to the downstream critical circuits. The controller can be set to operate in both auto-throw auto-return and auto-throw no auto-return modes.

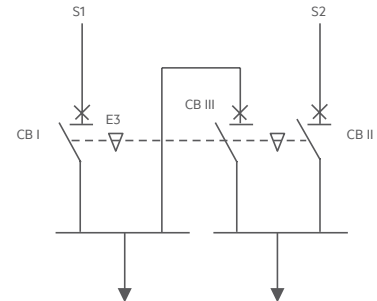

### E3 Applicable type

- Mains - Mains, which controls the transfer of the two-way inlet tape busbar

### E3 Automatic working mode

In the automatic operation mode, the E3 controller can perform real-time sampling of the phase voltage effective values of the two power sources. The control circuit processes the sampled data and displays the status of the two power sources in real-time on the panel. After voltage effective value and phase loss detection, the control circuit calculates against the user-set overvoltage and undervoltage values. When an abnormality occurs in any phase of the power supply voltage, the system automatically makes a power failure judgment, and the corresponding normal power supply indicator light goes out. The controller, based on the user-set working mode and parameters, carries out the appropriate delay. During the delay, the indicator light for the currently supplied power circuit breaker flashes. After the delay ends, the controller drives the circuit breaker to perform the corresponding make or break actions.

MEAT series automatic power conversion system E3 controller, in the automatic mode, there are two ways to work:

#### Auto transfer & retransfer

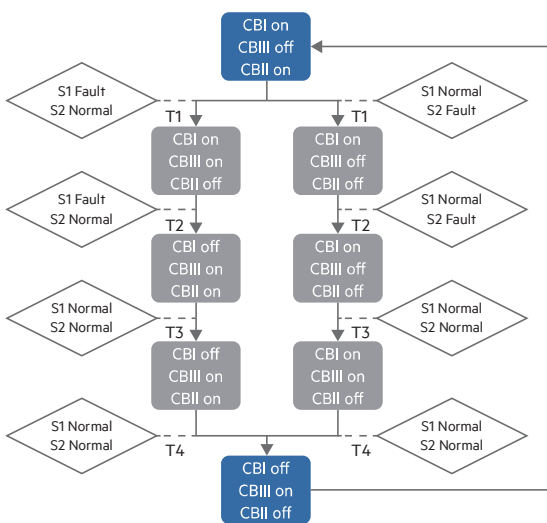

#### Auto transfer & Not retransfer

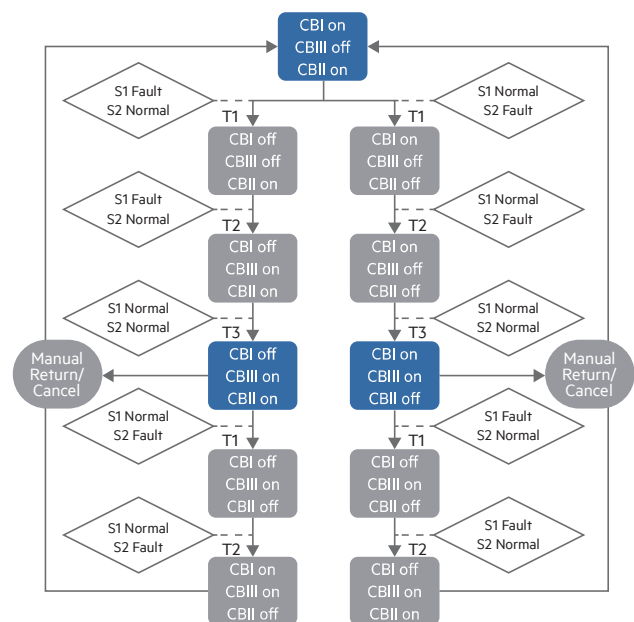

## MEAT LV Automatic Transfer Switch System

### E3 Low Voltage Automatic Transfer Switch System

#### E3 Non-automatic operation mode Remote operation mode

In the automatic mode, the E3 controller can be switched to remote operation mode, where users can use self-locking contacts without a power source connected to three terminals and a common terminal to achieve remote control:

- Remote I power supply
- Remote II power supply
- Remote switching (three circuit breakers)



#### Communication operation mode

The E3 controller, equipped with communication features for the user, not only enables remote control operations but also allows for reading the parameters collected by the power supply system. In the event of a fault, it can retrieve fault records.

- Communication protocol: MODBUS-RTU
- Communication interface: RS485

#### Fire operation mode

In case of emergency, the user can access the fire linkage terminal of the E3 controller through the self-locking contact, without external power supply, for fire operation and cut off all power supply.

- Fire linkage is the highest priority for all operating instructions
- In the above manual mode, other working modes are invalid

#### Manual operation mode

The humanized design of the E3 controller allows for easy installation on the cabinet door, enabling manual control mode locally. By operating different buttons on the control panel, direct priority switching can be performed:

- IOI, CBI, CBII close, CBIII break
- OII, CBII, CBIII close, CBI break
- IIO, CBI, CBIII close, CBII break
- IOO, CBI is close, CBII, CBIII is break
- OOI, CBII is close, CBI, CBIII is break
- OOO, all break

# MEAT LV Automatic Transfer Switch System

## Adapter

The MEAT automatic power transfer system is designed with a dedicated adapter for customer selection, featuring quick-connecting terminals. The adapter provides a fast connection method, which not only enhances the interlocking function between the executing circuit breakers but also greatly optimizes the secondary circuit design in the customer's usage phase, saving labor costs. It offers a systematic solution in terms of reliability and protective logic.

MEAT adapter provides two kinds of system solutions:

Adapter type	Suitable conversion system	Configuration checklist
E2-Adaptor	MEAT-E2 automatic powerconversion system	2 Adaptors (Separately installed on each breaker) Electrical interlocking harness Adaptors interlock harnesses with circuit breakers Adapter interlocks harness with controller Energy storage motor harness
E3-Adaptor	MEAT-E3 automatic powerconversion system	3 Adaptor (Separately installed on each breaker) Electrical interlocking harness Adaptors interlock harnesses with circuit breakers Adapter interlocks harness with controller Energy storage motor harness

### Functional characteristics of the adapter

- Sampling input for both main and backup power sources, with protection and isolation.
- Electrical interlocking between circuit breakers to achieve rapid connection.
- Realization of a quick connection between the circuit breakers and the MEAT-specific controller.
- Power supply for pre-charging the motors of the executing circuit breakers.
- Optimization of secondary design.
- Reduction of the complex wiring involved in installation and maintenance, avoiding errors.

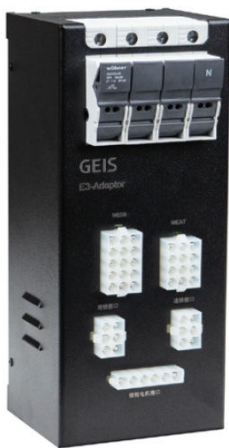

Adapters

# MEAT LV Automatic Transfer Switch System

## Adapter Wiring and Installation

### MEAT adapter wiring and installation

The adapter is fixed on the side of the circuit breaker, and the wiring harness connecting the circuit breaker to the adapter is already connected to the circuit breaker before leaving the factory.

The wiring between the controller and the adapter, the electrical interlock wire, and the power supply line for the energy storage motor can be selected according to the needs of the site with lengths of 3/5/10/15/20/30 m.

Note: For other lengths, please contact us

### E2-Adaptor wiring and installation

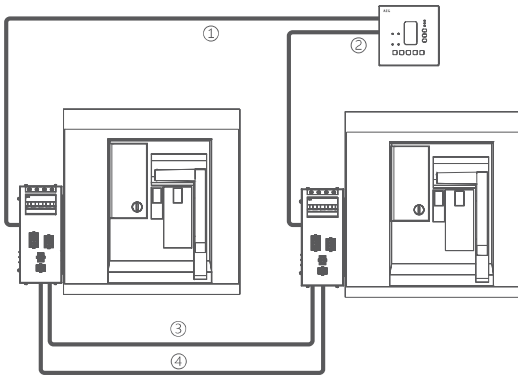

1. Controller and CBI connection cable
2. Cable connecting the controller to the CBII
3. Circuit breaker Electrical interlock cable between CBI and CBII
4. circuit breaker energy storage motor power supply line

### E3-Adaptor wiring and installation 1. Controller

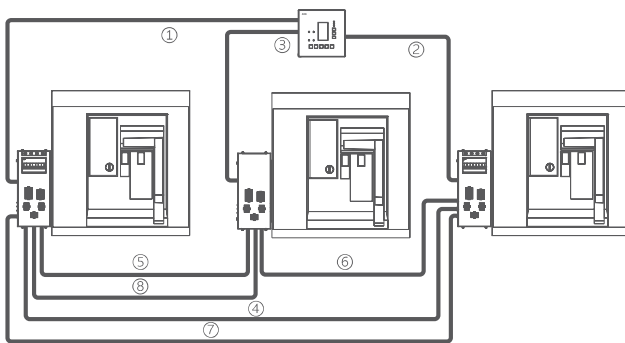

1. Connection cable between controller and CBI
2. Cable connecting the controller to the CBII
3. Connection cable between controller and CBIII
4. Circuit breaker CBI and circuit breaker CBII electrical interlock line
5. Circuit breaker CBI and circuit breaker CBIII electrical interlock line
6. Circuit breaker CBII and circuit breaker CBIII electrical interlock line
7. Circuit breaker CBI and circuit breaker CBII energy storage motor power supply line
8. Circuit breaker CBIII Energy storage motor power supply line

# MEAT LV Automatic Transfer Switch System

## E2 Controller Size

### E2 Controller Diagram

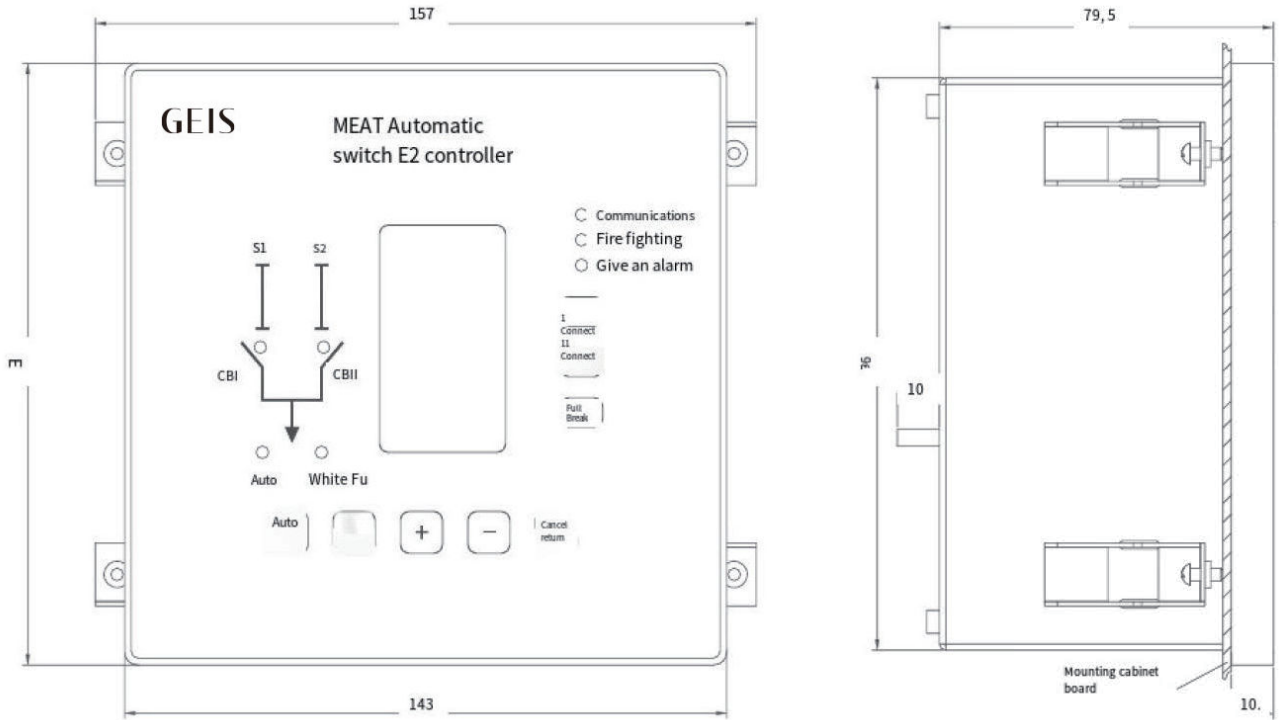

### E2 controller hole size

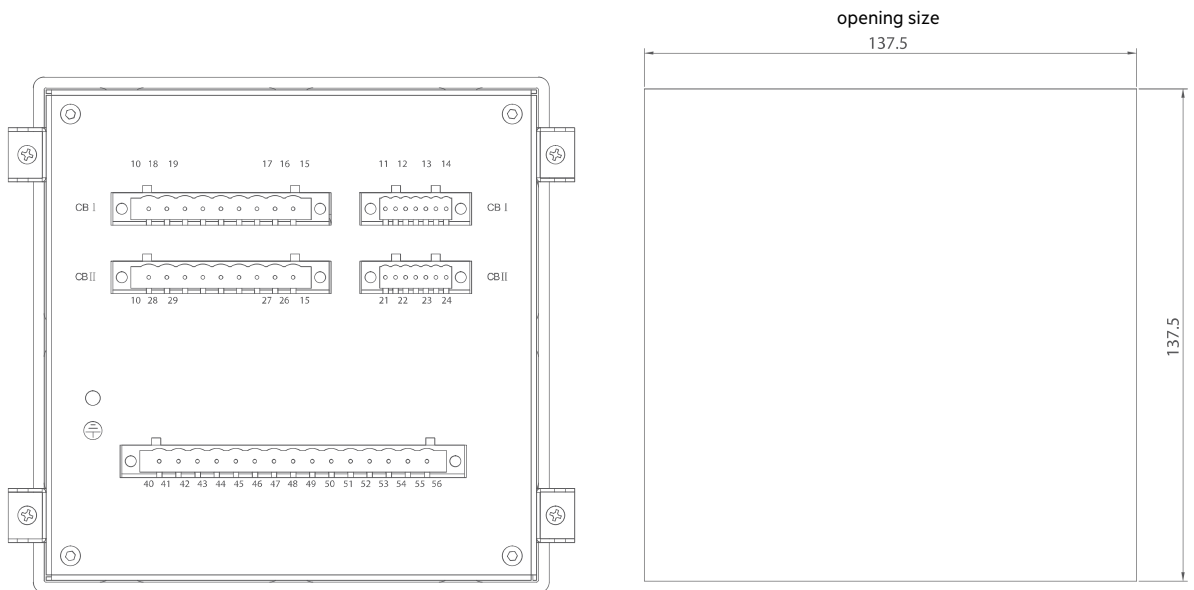

# MEAT LV Automatic Transfer Switch System

## E3 Controller Size

### E3 Controller Diagram

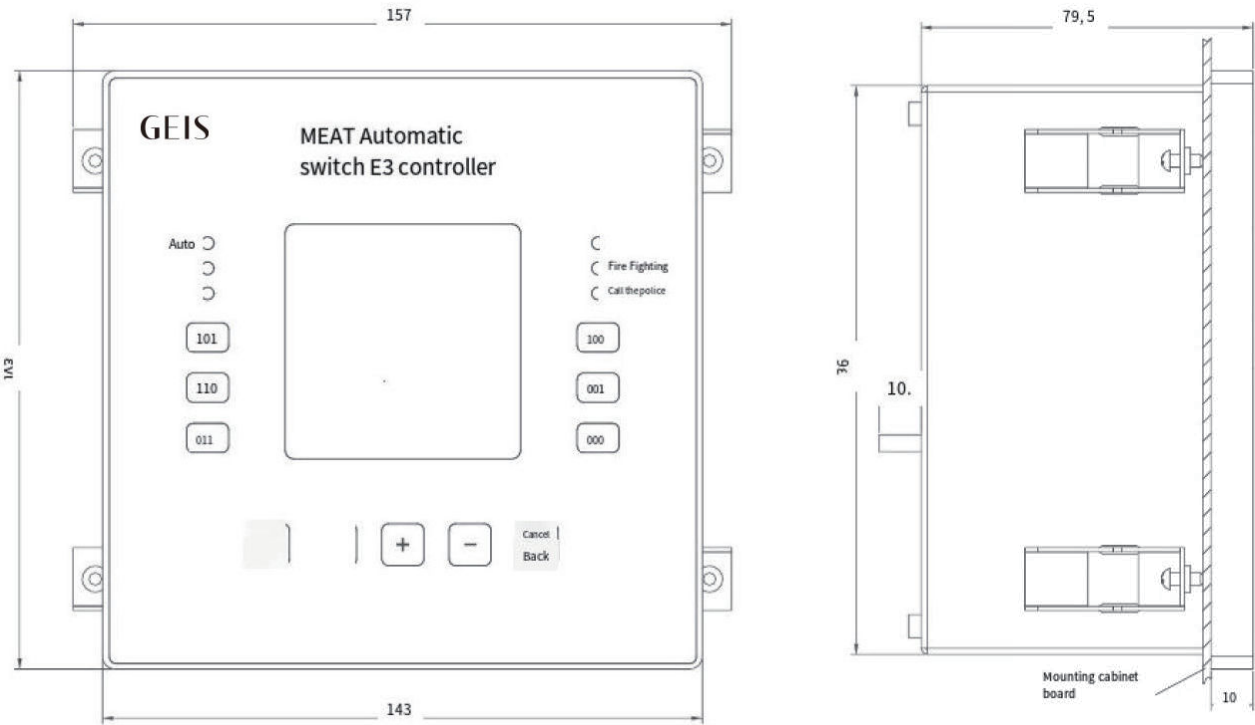

### E3 controller hole size

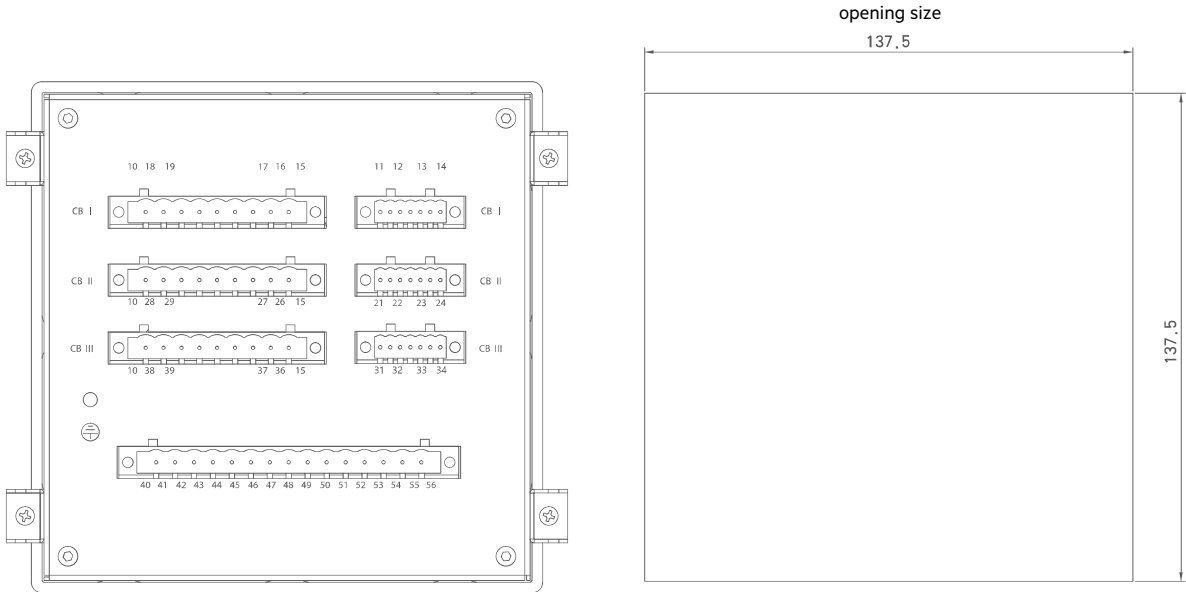

# MEAT LV Automatic Transfer Switch System

## Adapter Size

### Adapter diagram

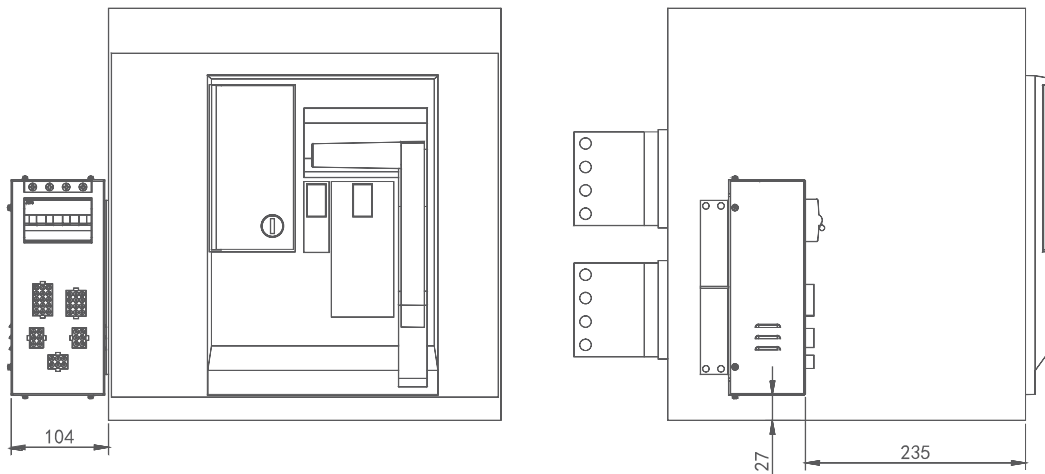
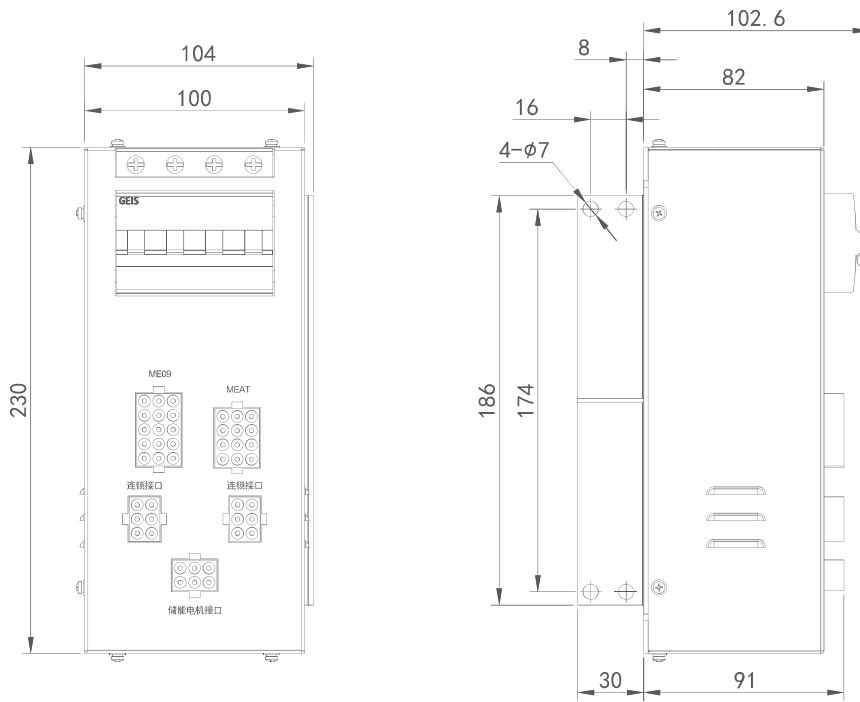

## MEAT LV Automatic Transfer Switch System

### Model Description

MEAT	Adapter type	Adapter type	Adapter type	Adapter type
Product Series	Rated current	Breaking ability	Number of poles	Controller
MEAT Automatic transfer switch system	04-400A	D: Icu=70kA, Ics=Icw=65kA	3:3 poles	E2: Regular function, two power supplies
	08-800A	H1: Icu=Ics=80kA, Icw=65kA	4:4 poles	E3: Regular function with busbar, two power supply
	10-1000A			
	12-1250A	H2: Icu=Ics=Icw=80kA		
	16-1600A	M: Icu=Ics=Icw=100kA		
	20-2000A			
	25-2500A			
	32-3200A			
	40-4000A			
	50-5000A			
	64-6400A			

### Standard Configuration Scheme

Circuit breaker installation method:

Standard configuration drawer-type air circuit breaker.

- Circuit Breaker protection unit:  
400-4000A Standard Configuration LSI Three-Stage Protection, Optional Additional Protections.
- Breaking ability:  
400-4000A Standard Configuration D-Break Products, 5000-6400A Standard Configuration M-Break Products.
- Number of poles:  
The number of poles can be 3P or 4P according to the system requirements
- Certification:  
Overall CCC Certificate

Note: MEAT non-standard configuration requirements, can be selected according to the parameter function of the air breaker, or call 400-820-5234

## MEAT LV Automatic Transfer Switch System

### Ordering Information

Order type	Breaking capacity (1cn) AC415V	Rated current In (A)	Number of poles	Air circuit breaker installation mode	Controller type	Stock type
MEAT04D3-E2	65kA	400	3P	drawer type	two-way power supply	Order product
MEAT08D3-E2	65kA	800	3P	drawer type	two-way power supply	Order product
MEAT10D3-E2	65kA	1000	3P	drawer type	two-way power supply	Order product
MEAT12D3-E2	65kA	1250	3P	drawer type	two-way power supply	Order product
MEAT16D3-E2	65kA	1600	3P	drawer type	two-way power supply	Order product
MEAT20D3-E2	65kA	2000	3P	drawer type	two-way power supply	Order product
MEAT25D3-E2	65kA	2500	3P	drawer type	two-way power supply	Order product
MEAT32D3-E2	65kA	3200	3P	drawer type	two-way power supply	Order product
MEAT40D3-E2	65kA	4000	3P	drawer type	two-way power supply	Order product
MEAT50M3-E2	100kA	5000	3P	drawer type	two-way power supply	Order product
MEAT64M3-E2	100kA	6400	3P	drawer type	two-way power supply	Order product
MEAT04D4-E2	65kA	400	4P	drawer type	two-way power supply	Order product
MEAT08D4-E2	65kA	800	4P	drawer type	two-way power supply	Order product
MEAT10D4-E2	65kA	1000	4P	drawer type	two-way power supply	Order product
MEAT12D4-E2	65kA	1250	4P	drawer type	two-way power supply	Order product
MEAT16D4-E2	65kA	1600	4P	drawer type	two-way power supply	Order product
MEAT20D4-E2	65kA	2000	4P	drawer type	two-way power supply	Order product
MEAT25D4-E2	65kA	2500	4P	drawer type	two-way power supply	Order product
MEAT32D4-E2	65kA	3200	4P	drawer type	two-way power supply	Order product
MEAT40D4-E2	65kA	4000	4P	drawer type	two-way power supply	Order product
MEAT50M4-E2	100kA	5000	4P	drawer type	two-way power supply	Order product
MEAT64M4-E2	100kA	6400	4P	drawer type	two-way power supply	Order product
MEAT04D3-E3	65kA	400	4P	drawer type	Two power supplies + busbar	Order product
MEAT08D3-E3	65kA	800	4P	drawer type	Two power supplies + busbar	Order product
MEAT10D3-E3	65kA	1000	3P	drawer type	Two power supplies + busbar	Order product
MEAT12D3-E3	65kA	1250	3P	drawer type	Two power supplies + busbar	Order product
MEAT16D3-E3	65kA	1600	3P	drawer type	Two power supplies + busbar	Order product
MEAT20D3-E3	65kA	2000	3P	drawer type	Two power supplies + busbar	Order product
MEAT25D3-E3	65kA	2500	3P	drawer type	Two power supplies + busbar	Order product
MEAT32D3-E3	65kA	3200	3P	drawer type	Two power supplies + busbar	Order product
MEAT40D3-E3	65kA	4000	3P	drawer type	Two power supplies + busbar	Order product
MEAT50M3-E3	100kA	5000	3P	drawer type	Two power supplies + busbar	Order product
MEAT64M3-E3	100kA	6400	3P	drawer type	Two power supplies + busbar	Order product
MEAT04D4-E3	65kA	400	4P	drawer type	Two power supplies + busbar	Order product
MEAT08D4-E3	65kA	800	4P	drawer type	Two power supplies + busbar	Order product
MEAT10D4-E3	65kA	1000	4P	drawer type	Two power supplies + busbar	Order product
MEAT12D4-E3	65kA	1250	4P	drawer type	Two power supplies + busbar	Order product
MEAT16D4-E3	65kA	1600	4P	drawer type	Two power supplies + busbar	Order product
MEAT20D4-E3	65kA	2000	4P	drawer type	Two power supplies + busbar	Order product
MEAT25D4-E3	65kA	2500	4P	drawer type	Two power supplies + busbar	Order product
MEAT32D4-E3	65kA	3200	4P	drawer type	Two power supplies + busbar	Order product
MEAT40D4-E3	65kA	4000	4P	drawer type	Two power supplies + busbar	Order product
MEAT50M4-E3	100kA	5000	4P	drawer type	Two power supplies + busbar	Order product
MEAT64M4-E3	100kA	6400	4P	drawer type	Two power supplies + busbar	Order product

# MARS Automatic Transfer Switch

## AT50 PC-level Bypass Automatic Transfer Switch AT30

### Products

Data centers, banks, stock exchanges, hospitals, and other facilities require uninterrupted power supply around the clock. Once the dual power supply equipment that ensures continuous power supply needs to be maintained, it is inevitable that important loads cannot work properly. To meet such needs, GEIS has launched the AT50 PC-level bypass automatic transfer switch.

The AT50 PC-level bypass automatic transfer switch product consists of two main modules: the automatic transfer switch itself and the bypass switch. The main body part uses AEG's advanced manufacturing processes and production experience, offering fast transfer speed and high reliability.

The bypass part also employs a reliable driving mechanism and high-power silver alloy contacts, which can provide continuous power supply to the load when the main body needs maintenance and repair.

The main body and the bypass part both have mechanical and electrical interlocks, and a different-side interlocking mechanism is used between the two parts to ensure that the primary power supply and the backup power supply will not close at the same time, causing a power supply accident.

The AT50 main unit is designed with a draw-out mechanism, which allows for quick isolation and removal for maintenance and repair once the bypass is closed. With a guide rail design, the main unit is easy to pull out, and the load remains powered throughout the process.



### Product Features

- Mechanical and electrical dual interlocking, bypass and main body interlock
- The automatic transfer switch main body can be pulled out for maintenance and repair
- The bypass part is operated electrically, with fast switching speed and high safety
- AC-33, 10Ie high breaking capacity
- Dedicated intelligent controller with Chinese and English display

### Model Description

<b>AT50</b>	-	<b>630</b>	/	<b>4</b>	<b>MT500</b>	<b>I</b>
<b>Product series</b>		<b>Rated current</b>		<b>Poles</b>	<b>Controller type</b>	<b>Bypass type</b>
AT10 series automatic switch		160-160A		3:3 poles	MT500: Bypass dedicated mode	I: Single bypass model
		.....		4:4 poles		II: Double bypass type
		2500-2500A				

# MARS Automatic Transfer Switch

## AT50 PC-level Bypass Automatic Transfer Switch AT30

### Performance Parameter

Specification and model	AT50				
Rated operating current Ie (A)	160, 200, 250	350, 400, 500, 630	800, 1000, 1250, 1600	2000	2500
Rated insulation voltage (V)	AC1000				
Rated operating voltage (V)	AC400/690				
Rated operating frequency (Hz)	50				
Uimp (kV)	8				
Utilization category	AC-33A/B				
Appliance level	200				
Iq (kA)	80				
Icw (kA)	25	80			
Rated breaking and making capacity	10Ie				
Mechanical life	10000				
Electrical life	6000				
Conversion time	100ms				
Control circuit	Rated control power supply voltage AC220V 50Hz, 85%~110%Ue				
Auxiliary loop	2NO AC 110V5A/220V3A DC 220V/0.2A				

### Controller Function

Model number	MT500 Series
Installation method	Split type
Rated operating voltage	AC220V
Rated frequency	50/60Hz
Undervoltage conversion	50%-99%
Overpressure conversion	101%-150%
Frequency protection	-
Conversion delay	-
Auto transfer & retransfer	0-3600S
Auto transfer & not retransfer	-
Mutual backup	-
Phase Angle detection	-
LCD Liquid Crystal Display	-
Main power optional	-
Practice regularly	-
Record of events	200 pieces

Model number	MT500 Series
Load offloading	-
Fire protection linkage	(Standard in Section III)
Current detection	-
Power detection	-
Operating temperature	-25E to +70E
Humidity	@ 95%RH
Editable input	12
Editable output	12
Remote Control	-
Communication interface	RS485
Communication protocol	ModBUS
Four remote function	-
Dimension (L*W*H)	260*180*54
Hole size (mm)	242x161

# MARS Automatic Transfer Switch

**AT50 PC-level Bypass Automatic Transfer Switch AT30**

**AT50-250**

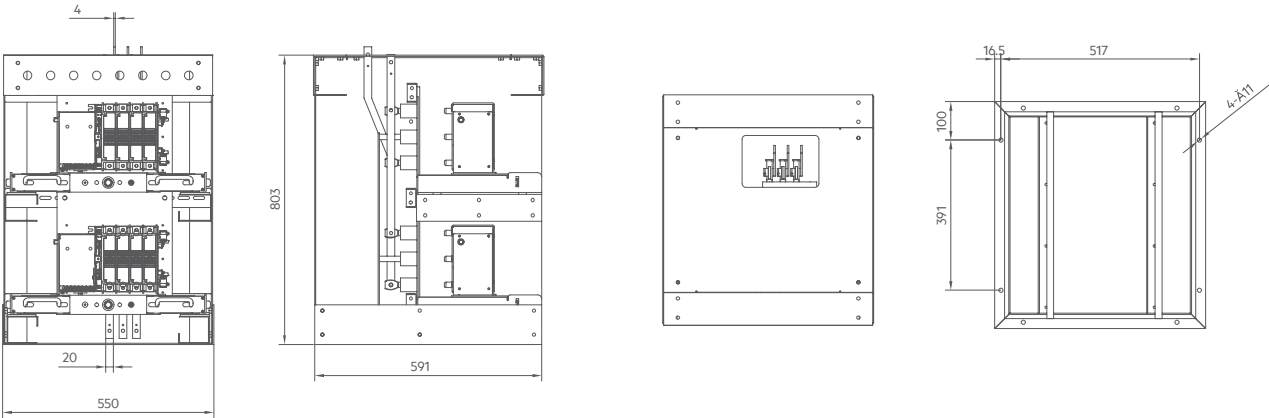

**AT50-1600~2500**

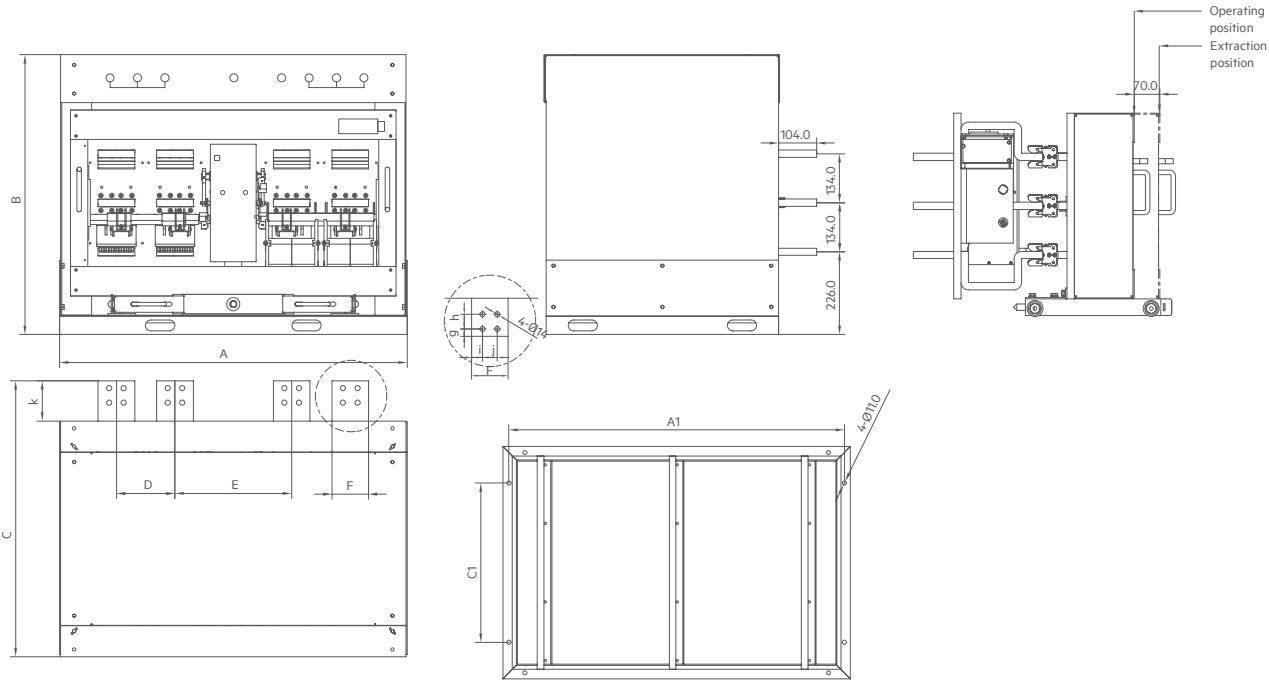

Specification	A	B	C	A1	C1	D	E	F	g	h	i	j	k
1600A	860	765	795	827	435	120	278	60	20	30	15	30	90
2500A	1020	765	815	987	435	160	319	100	20	40	30	40	110

# MARS Automatic Transfer Switch

## AT30 Industrial PC-level Automatic Transfer Switch

### Products

AT30 Industrial PC-level automatic transfer switch is a new generation of PC-level industrial automatic transfer switch launched by GEIS for the high continuous requirements of power supply in intelligent industries, data centers, important public places, etc. , by improving the product design platform and structure, using the excitation drive technology accumulated over the years, with the most advanced double-contact structure and fast arc extinguishing system. When the common power supply appears loss of voltage, undervoltage, overvoltage, lack of phase, over frequency, under frequency and other faults, it can quickly convert the important load from the common power supply to the standby power supply automatically, so as to ensure the continuity and reliability of power supply.

- Rated current: 16-4000A
- Conversion time: ≤100ms
- Utilization category: AC-33A
- Overlapping conversion feature of neutral line is optional
- Double interlocking: electrical and mechanical



The product is especially suitable for public places, data communication, intelligent facilities and other primary loads and especially important loads in the primary load of power continuity guarantee. Besides, it can also be widely used in other power distribution circuit which requires uninterrupted normal power supply.

### Model Description

AT30	P	II	-	100	/	4	MT100
<b>Product Series</b>	<b>Product Type</b>	<b>Rank</b>		<b>Rated current</b>		<b>Poles</b>	<b>Controller type</b>
AT30 Industrial automatic transfer switch	P : PC	II - two position III - three position		16-16A ..... 100-100A ..... 250-250A ..... 400-400A ..... 630-630A ..... 4000-4000A		3 -3P 4 - 4P 3N - Neutral overlap	MT100: Intelligent Controller MT200: Multifunctional controller H: Standard controller

Note: III For products above 1600A, please contact GEIS:

II Optional neutral overlap conversion for II-segment products, up to 630A

Model H controller is suitable for 800A and above, please choose model MT controller below 800A

# MARS Automatic Transfer Switch

## AT30 Industrial PC-level Automatic Transfer Switch

### Conversion Scheme

AT30 industrial PC-level automatic transfer switch, equipped with high-performance H-type controller, can be applied to the standby system of two mains and mains - generator. AT30 adopts anti-idle secondary terminal design which is safe and convenient to introduce the power supply from the main circuit. H-type controller can be used to monitor the common power supply's loss of voltage, lack of phase, under voltage, overvoltage, under frequency, overfrequency, phase sequence and other parameters, while monitoring whether the standby power supply is normal. When the main power circuit has voltage loss or power failure, undervoltage, overvoltage, over frequency, under frequency, phase break, phase sequence and other faults, the switch will be automatically put into the standby power circuit (can be adjusted as delayed); When the power supply of the main power loop returns to normal, the switch will automatically throw the load back to the main power loop (can be adjusted as delayed).

The intelligent controller has the functions of automatic charge and automatic recovery, automatic charge without recovery, communication, etc. It can realize manual operation, automatic mode, remote control, fire linkage and communication operation mode.



### Performance Parameters

Frame current	A	100	250	400	630	1600	2500	4000
Appliance level		PC						
Standard compliant		GB/T 14048.11						
Rated current	A	16-100	125-250	320-400	500-630	800-1600	800-2500	800-4000
Number of poles		3P, 4P, 3N(Neutral lines Overlap)				3P, 4P		
Rated voltage AC	V	400						
Rated insulation voltage	V	1000				800		1000
Uimp	kV	12				8		12
Off time	ms	<100				<50		
Utilization category		AC-33A						
Iq MCCB	kA	70				-	-	-
Icw 1s	kA	-	-	-	-	42	50	85
Mechanical life	time	12000	12000	10000	10000	10000	10000	10000
Electrical life	time	6000	6000	6000	6000	6000	6000	6000
Overall dimensions L*W*H	mm	262*231*123	292*284*133	424*381*170	464*381*170	600*600*328	740*640*349	780*642*320

## MARS Automatic Transfer Switch

### AT30 Industrial PC-level Automatic Transfer Switch

#### MT Series Controller

Model number	H	MT100	MT200
Installation method	split	split	split
Rated operating voltage	AC220V	AC220V	AC220V
Rated frequency	45-65Hz	50/60Hz	50/60Hz
Undervoltage conversion	70%-95%	70%-95%	50%-95%
Overpressure conversion	105%-120%	105%-120%	105%-150%
Frequency protection	■	■	■
Conversion delay	0-9999s	0-250S	0-9999s
Auto transfer & retransfer	■	■	■
Auto transfer & not retransfer	■	■	■
Mutual backup	■	■	■
Phase Angle detection	□	■	■
LCD Liquid Crystal Display	■	■	■
Active/standby powersupply selection	-	-	■
Practice regularly	■	-	■
Record of events	■	■	■
Load offloading	-	-	■
Fire linkage (Fire cutting)	■	■	■
Current detection	-	-	□
Ambient temperature	-10°C +50°C	-25°C ~+70°C	
Ambient humidity	< 90%RH		
Programmable output	-	1	6
Remote control	■	■	■
Communication interface	RS485	RS485	RS485
Communication protocol	ModBUS	ModBUS	ModBUS
Four-remote function	■	■	■
Measurement accuracv	≤ 1%	≤ 0.5%	≤ 0.5%
Dimension (length x height x depth)	208.5×135×96.5	139×120×50	198×155×54
Hole size(mm)	195×122	130×111	186×141

Note:

■ : Standard □ : Optional - : None

MT100, MT200 controller for 630A and below products

800A and above, please choose the H-type controller

The standard connection cable of the controller is 1.8m, if you need other lengths, please contact GEIS

# MARS Automatic Transfer Switch

**AT30 Industrial PC-level Automatic Transfer Switch**

**ATS Size, 16-630A**

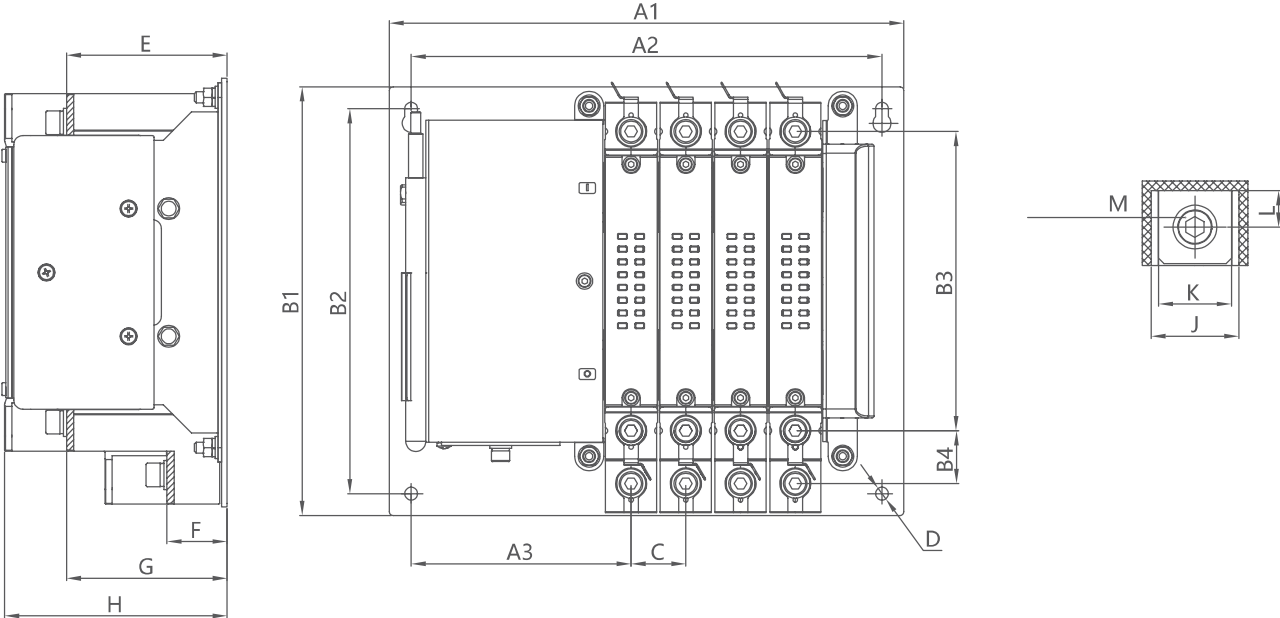

Mondel number	A1 (3p/4p)	A2 (3p/4p)	A3	B1	B2	B3	B4	C	D	E	F	G	H	J	K	M	L
AT30-100 II	252/282	228/258	120.5	235	211	164	29	30	Φ7	88	33	88	126	21	16	M8	10.5
AT30-100 III	277/307	253/283	145.5														
AT30-250 II	287/322	255/290	130	287	263	224	27	35	Φ7	95.5	32.5	95.5	134	25	22	M8	10.5
AT30-250 III	307/342	275/310	150														
AT30-400 II	406/466	342/402	150.5	391	361	298	41	60	Φ9	110.5	35	110.5	172	48	40	M12	20
AT30-400 III	426/486	362/422	170.5														
AT30-630 II	438/508	373/443	154.5	391	361	298	41	70	Φ9	110.5	35	110.5	172	58	44	M12	20
AT30-630 III	456/526	393/463	174.5														



# MARS Automatic Transfer Switch

## AT30 Industrial PC-level Automatic Transfer Switch

### ATS Size, 3200-4000A

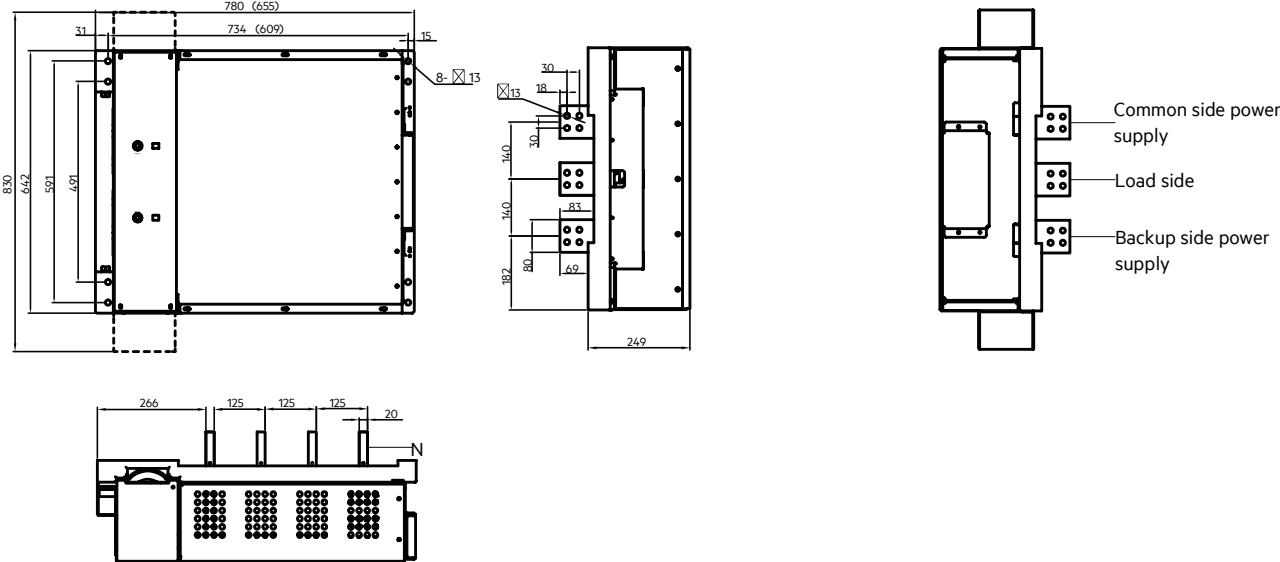

# MARS Automatic Transfer Switch

## AT30 Industrial PC-level Automatic Transfer Switch

### ATS Size, Controller

H

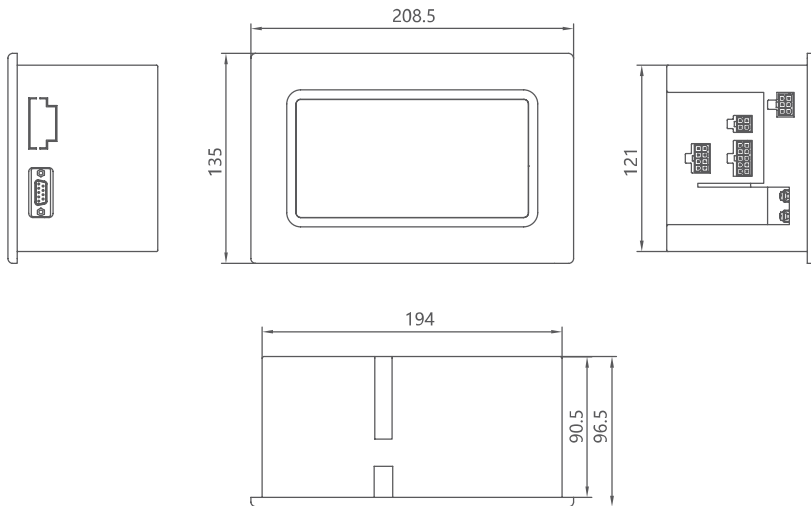

MT 100

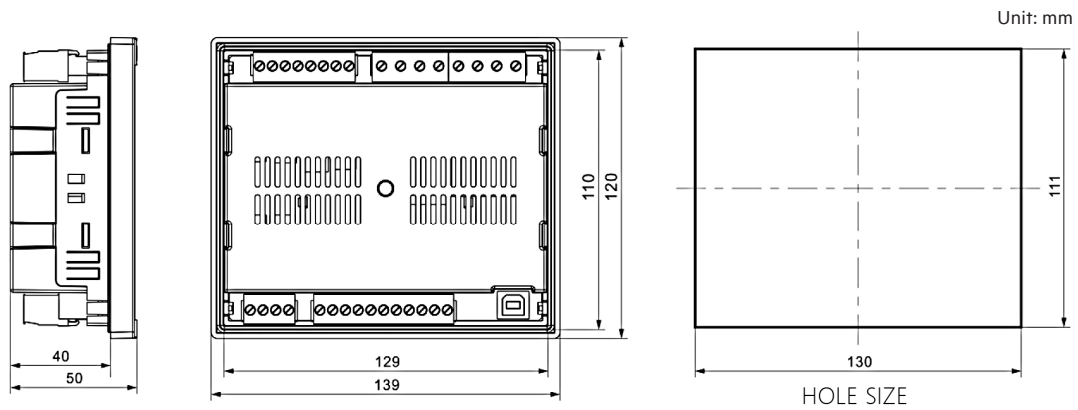

MT 200

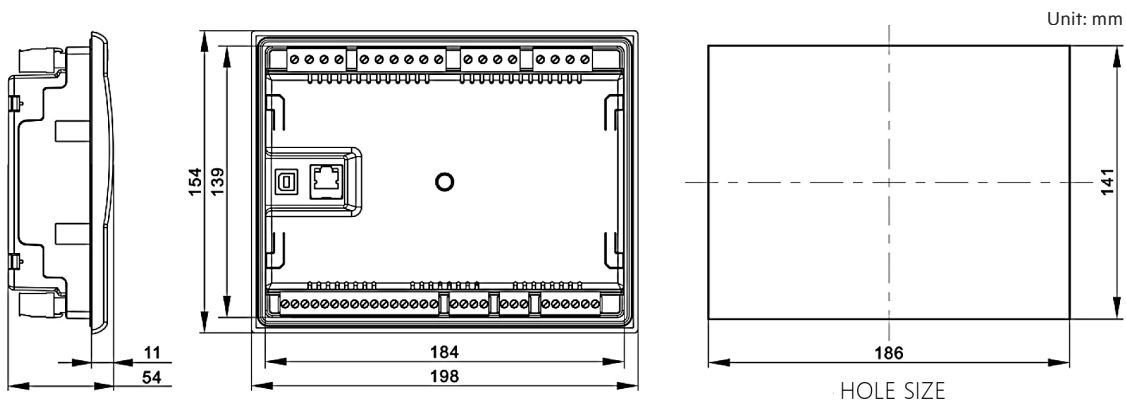

## MARS Automatic Transfer Switch

### AT20 Construction PC-level Automatic Transfer Switch

#### Products

AT20 building PC grade automatic transfer switch products are composed of automatic transfer switch, special controller, and excitation transfer mechanism. The structure part adopts GEIS advanced manufacturing technology and production experience, delivering fast conversion speed and high reliability. Reliable driving mechanism and high-power silver alloy contacts enable long-term work and make it not easy to oxidize, to ensure that the electrical performance meets the needs of the system. The product has mechanical and electrical interlocking, and the controller has logical locking function to ensure that two power sources are not closed at the same time. AT20 structure adopts modular design, controller and conversion unit. So the body failure can be quickly replaced or maintained. The controller is connected with the switch by data cable, and can be replaced without turning off the power.



#### Product Features

- New excitation mechanism, efficient and reliable  
High performance excitation coil, low energy consumption, maintenance-free, contact conversion speed can reach 100ms, minimize the power failure time of key equipment.
- Excellent performance, AC-33B  
With high quality silver alloy contacts, the product can be switched on and off 10 times the rated current
- Strict environment, stable ATP910 reliability test, EMC level reached E2, good stability and reliability under harsh environment
- easy configuration for different requirements EA, EH, MT series intelligent controller, according to different needs of various users, can be flexibly configured
- Interconnectivity, small size with big wisdom  
A full series of industrial-grade chips, support ModBUS communication, real-time power monitoring, smaller size with complete functions

#### Application field

- Data Center
- Commercial buildings
- Sports venues
- Chemical metallurgy
- Military and national defense

#### Working conditions

Operating temperature: -25°C ~ +85°C

Altitude: No more than 2000m

Ambient humidity: When the maximum temperature is +55°C, the relative humidity of the air does not exceed 95%

Pollution level: Class III

#### Meeting standards

- IEC 60947-1 General
- IEC 60947-6-1 switch electrical appliances

# MARS Automatic Transfer Switch

## AT20 Construction PC-level Automatic Transfer Switch

### Model Description

AT20	II	-	630	/	4	EH
<b>Product line</b> AT20 automatic transfer switch	<b>Rank</b> II - Two stage III - Three stage		<b>Rated current</b> 160-160A ..... 630-630A		<b>Poles</b> 3:3 poles 4:4 poles	<b>Controller type</b> EA: Standard controller EH: Intelligent controller M: Split intelligent control

Note: The standard connection cable for M-type split controller is 1.8m, if you need other lengths, please contact GEIS.

### Performance Parameters

Specification and model	AT20			
Rated operating current Ie (A)	16, 32, 40, 63	80, 100, 125	160, 200, 250	300, 400, 630
Rated insulation voltage Ui (V)	AC800			
Rated operating voltage (V)	AC 400			
Rated operating frequency (Hz)	50			
Utilization category	AC-33B			
Poles	3, 4	3, 4	3, 4	3, 4
Rank	II/III	II/III	II/III	II/III
Appliance level	PC Class			
Iq (kA)	120			
Rated breaking and making capacity	10Ie			
Mechanical life	10000	10000	10000	10000
Electrical life	6000	6000	6000	6000
Conversion time	< 100ms			
Control circuit	Rated control powersupplyvoltage AC220V50Hz,85%~110%Ue			
Auxiliary loop	2NO AC 110V5A/220V3A DC 220V/0.2A			

**MARS Automatic Transfer Switch****AT20 Construction PC-level Automatic Transfer Switch****Controller Function**

Model number	EA	EH	MT100
Installation mode	All-in-one	One-piece	split
Controller operating voltage	AC220V	AC220V	AC220V
Rated frequency	50Hz	50Hz	50/60Hz
Undervoltage conversion	70%, 75%, 80%, 85%	65%-85%	70%-95%
Overpressure conversion	110%, 115%, 120%, OFF	105%-130%	105%-120%
Frequency protection	-	■	■
Conversion delay	0.1-30s	0.1-255s	0-250s
Auto transfer & retransfer	■	■	■
Auto transfer & not retransfer	■	■	■
LED indicator	■	■	■
LCD liquid crystal display	-	■	■
Event record	-	■	■
Load offloading	-	□	□
Fire linkage	■ (Standard in Section III)	■ (Standard in Section III)	■ (Standard in Section III)
Programmable output	-	-	1
Remote control	-	□	■
Communication interface	-	RS485 (optional)	RS485
Communication protocol	-	ModBUS (optional)	ModBUS
Powersupplytype	Mains - Mains	Mains-Mains.Mains -Generator	Mains-Mains.Mains -Generator
Measurement accuracy	-	≤ 0.5%	≤ 0.5%
Generator start signal	■	■	■
Dimension (length x height x depth)	-	-	139×120×50
Opening size(mm)	-	-	130×111

\*If the power supply type is mains - generator, note when ordering

# MARS Automatic Transfer Switch

## AT20 Construction PC-level Automatic Transfer Switch

### ATS Size

Panel safety distance (S1) :30mm (AC400V)

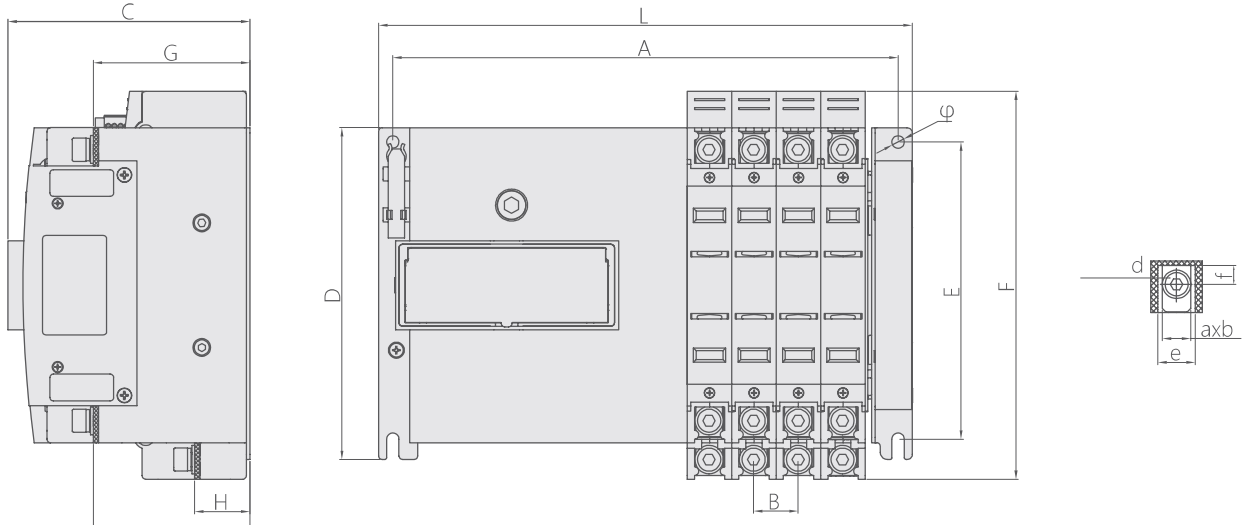

Mondel number	L	A	D	E	F	B	C	G	H	J	Φ	d	f	e	axb
AT20P 16-125/3	278	262	186.5	167	219	25	137	88	32	88	Φ7	M8	8	17	15x3
AT20P 16-125/4	303	282	186.5	167	219	25	137	88	32	88	Φ7	M8	8	17	15x3
AT20P 160-250/3	309	293	186.5	167	219	35	137	88	32	88	Φ7	M8	9.5	27	20x4
AT20P 160-250/4	344	328	186.5	167	219	35	137	88	32	88	Φ7	M8	9.5	27	20x4
AT20P 400-630/3	401.5	380.5	320	302	356	60	171	113.5	47	113.5	Φ9	M12	25.5	48	40x6
AT20P 400-630/4	401.5	440.5	320	302	356	60	171	113.5	47	113.5	Φ9	M12	25.5	48	40x6

### MT100

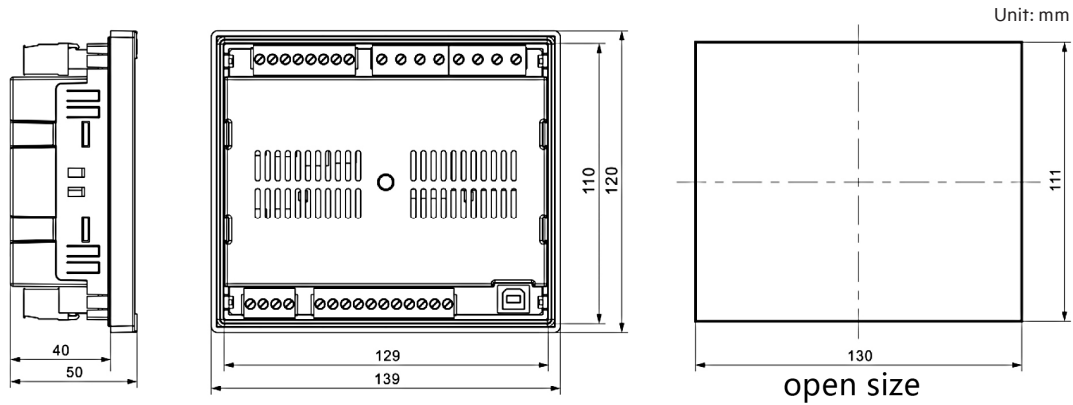

# MARS Automatic Transfer Switch

## AT10 Terminal PC-level Automatic Transfer Switch



### Products

AT10 PC-level automatic transfer switch uses fast excitation drive mechanism and the operating mechanism has a reliable mechanical interlock device, to ensure that in any case, the common power supply and standby power can not be closed at the same time. The device can be in the fast conversion while taking into account the safety of the conversion, perfect to show the excellent performance of continuous power supply. The electrical parameters of the main and standby circuits can be monitored at the same time to fully guarantee the reliability of power supply.

### Type of Control

- Full-featured protection and conversion protection for no voltage, no phase, under voltage and over voltage, monitoring standby power supply ntegrated/split controller, humanized operation control
- Manual, automatic, button, communication remote control operation, easy experience automatic charge and automatic recovery,automatic charge without recovery and mutual backup, on-site selection
- Support mains - mains, mains - generator mode
- Fire linkage function
- Transfer delay and return delay time can be adjusted
- The neutral line overlaps and the main and standby neutral lines overlap during the contact conversion process

### Model Description

AT10	P	II	200	3	C
<b>Product Series</b>	<b>Appliance level</b>	<b>Rank</b>	<b>Rated current</b>	<b>Poles</b>	<b>Controller type</b>
AT10 automatic change-over	P: PC	II: two bits, MAX400A III - Three bits	16-16A ..... 125-125A ..... 250-250A ..... 800-800A ..... 2500-2500A	3 - 3P 4 - 4P <u>3N - Neutral overlap</u>	A: Terminal type, the largest400A B: One piece, liquid crystal type, maximum250A C: Split type, intelligent type, liquid crystal type, maximum800A D: Split, intelligent, liquid crystal, 1000-2500A

# MARS Automatic Transfer Switch

## AT10 Terminal PC-level Automatic Transfer Switch

### Control



#### Type A controller, end type, 16-400A

Mainly for the mains - mains type, suitable for two mains, standby system. Type A controller monitors the common power supply voltage loss, phase loss, while monitoring whether the standby voltage is normal or not. When the main power supply circuit experiences any phase break or voltage loss, the switch automatically put into the standby power supply circuit; When the main power supply loop recovers, the switch will automatically throw the load back to the main power supply loop.



#### Type B controller, standard, 16-250A

Mainly for the mains - mains type, mains - generator model, suitable for two mains and mains - generator main and standby system. B-type controller monitors the common power supply voltage loss, phase loss, undervoltage, overvoltage, while monitoring whether the standby voltage is normal. When the main power supply circuit has voltage loss or power failure, undervoltage, overvoltage and break fault, the switch will automatically change into the standby power supply circuit (adjustable delay); The controller can be set to automatic charge and automatic recovery, automatic charge without recovery and mutual backup functions. We provide a clear Chinese menu LCD display.

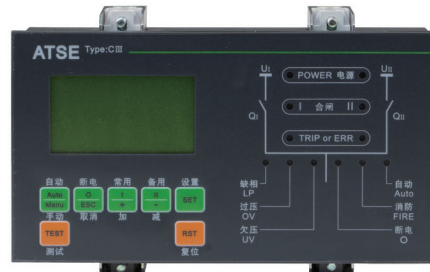

#### Type C controller, intelligent type, 16-800A

#### Type D controller, intelligent type, 1000-2500A

Mainly for the mains - mains type, mains - generator model, suitable for two mains and mains - generator, main and standby system. C-type controller monitors the common power supply voltage loss, phase loss, undervoltage, overvoltage, while monitoring whether the standby voltage is normal. When the main power supply circuit has voltage loss or power failure, undervoltage, overvoltage, break fault, the switch will automatically put into the standby power supply circuit (delay adjustment); When the power supply of the main power supply loop returns to normal, the switch automatically throws the load back to the main power supply loop (can adjust the delay). The controller has the functions of automatic charge and automatic recovery, automatic charge without recovery, mutual backup and communication, and provides a clear Chinese menu LCD display.

# MARS Automatic Transfer Switch

## AT10 Terminal PC-level Automatic Transfer Switch

### Performance Parameters

Type specification		AT10P-63		AT10P-125		AT10P-250		AT10P-800	
Rated operating current (A) Ie <sup>(1)</sup>		16-63		80-125		160-250		300-400	500-800
Rated operating voltage (U) Ue		AC 400		AC 400		AC 400		AC 400	
Rated insulation voltage (V) Ui		800		800		800		800	
Rated impulse Withstand Voltage (kV) Uimp		8		8		8		8	
Rated frequency (Hz)		50/60		50/60		50/60		50/60	
Poles (P)		3, 4		3, 4		3, 4		3, 4	
Operating current (A)	110V AC/DC	6		8		8		12	16
	220V AC/DC	3		4		4		6	8
Trip Current (A)	110V AC/DC	1.4		1.4		1.4		2	2.4
	220V AC/DC	0.7		0.7		0.7		1	1.2
Iq (kA)	Reachable value when protected by circuit breaker	35		50		50		65	65
	The value can be reached when protected by a fuse	100		120		120		120	120
Making and breaking ability Cosφ=0.45		10Ie		10Ie		10Ie		10Ie	10Ie
Service life (times)	- Electric	6000		6000		6000		6000	6000
	- Mechanical	10000		10000		10000		10000	10000
Off time (s)	II < 0.2	II < 0.2		II < 0.2		II < 0.2		-	-
	III < 0.7	III < 0.7		III < 0.7		III < 0.7		III < 0.7	III < 1.2
mode of connection	Front wiring	■		■		■		■	■
Appliance level		PC		PC		PC		PC	PC
Utilization category		AC-33A		AC-33B		AC-33B		AC-33B	AC-33B
Number of main contact positions		two-tier	three-tier	two-tier	three-tier	two-tier	three-tier	three-tier	three-tier
Controller	A	□	□	□	□	□	□	-	-
	B	□	□	□	□	□	□	-	-
	C	□	□	□	□	□	□	■	■
Meet the criteria		GB/T 14048.11, IEC 60947-6-1							

■ standard configuration □ Optional configuration - This function is not available

Note: (1) See quick selection table for more rated current

# MARS Automatic Transfer Switch

## AT10 Terminal PC-level Automatic Transfer Switch

### Performance Parameters

Type specification		AT10P-1250				AT10P-2500					
Rated operating current (A) I <sub>e</sub>		1000		1250		1600		2000		2500	
Rated operating voltage (U) U <sub>e</sub>		AC 400				AC 400					
Rated insulation voltage (V) U <sub>i</sub>		800				800					
Rated impulse Withstand Voltage (kV) U <sub>imp</sub>		8				8					
Rated frequency (Hz)		50/60				50/60					
Poles (P)		3	4	3	4	3	4	3	4	3	4
Operating current (A)	110V AC/DC	12	16	12	16	20	24	20	24	20	24
	220V AC/DC	6	8	6	8	10	12	10	12	10	12
Trip Current (A)	110V AC/DC	4				6					
	220V AC/DC	2				2					
I <sub>q</sub> (kA)	Reachable value when protected by circuit breaker	50				50					
	The value can be reached when protected by a fuse	120				120					
Making and breaking ability Cosφ=0.35		10I <sub>e</sub>				10I <sub>e</sub>					
Service life (sub)	- Electric	6000				6000					
	- Mechanical	10000				10000					
Off time (s)		≤ 0.2				≤ 0.2					
Wiring method		Wiring behind the board				Wiring behind the board					
Appliance level		PC				PC					
Utilization category		AC-33B				AC-33B					
Number of main contact positions		III				III					
Controller		D				D					
Auxiliary contact	Common power supply	2NO+2NC				2NO+2NC					
	Backup power	2NO+2NC				2NO+2NC					
Meet the standard		GB/T 14048.11, IEC 60947-6-1									

# MARS Automatic Transfer Switch

## AT10 Terminal PC-level Automatic Transfer Switch

### Controller Function

Controller		A (16-400A)	B (16-250A)	C (16-800A)	D (1000-2500A)
Mounting form		Plug-in type	One-piece	Split	Split
Rated operating voltage		AC220V	AC220V	AC220V	AC220V
Rated operating frequency		50/60Hz	50/60Hz	50/60Hz	50/60Hz
2/3 working position	- Common power supply closure	■	■	■	■
	- Common power supply closure	■	■	■	■
	- The two power supplies are disconnected <sup>(1)</sup>	■	■	■	■
4 ways to operate	- automatic operation	■	■	■	■
	- manual manipulation	■	■	■	■
	- Controller key operation	-	■	■	■
	- Communication remote control	-	-	□	■
Controller key operation	- Press to go to Common	-	■	■	■
	- Press to go to Standby	-	■	■	■
	- Press the button to go to double	-	■	■	■
Automatic operation	- Monitoring of common undervoltage	-	■	■	■
	- Overpressure is often monitored	-	■	■	■
	- Loss of pressure is commonly monitored	■	■	■	■
	- Phase disconnection is commonly monitored	■	■	■	■
	- Monitor standby undervoltage	-	■	■	■
	- Monitor standby overpressure	-	■	■	■
	- Monitor standby loss of pressure	-	■	■	■
	- Monitor standby phase failure	-	■	■	■
	- Monitor standby phase failure	-	-	-	The current transformer needs to be configured
	- generator control	■	■	■	■
	- Fire signal disconnection <sup>(1)</sup>	■	■	■	■
	- Auto transfer & retransfer	■	■	■	■
	- Mutual backup	-	■	■	■
- Auto transfer & not retransfer	-	■	■	■	
Overhaul test	- Push button operation	-	-	■	■

■ standard configuration □ Optional configuration - This function is not available

Note: (1) Three-segment bits have this function

# MARS Automatic Transfer Switch

## AT10 Terminal PC-level Automatic Transfer Switch

### Controller Function

Controller		A (16-400A)	B (16-250A)	C (16-800A)	D (1000-2500A)
show	- Regular backup power supply	■	■	■	■
	- The common power supply is divided and closed	■	■	■	■
	- The backup power supply is disconnected	■	■	■	■
	- Fault display	-	■	■	■
	- Common supply voltage	-	■	■	■
	- Standby supply voltage	-	■	■	■
	- Mode setting	-	■	■	■
	- Delay time display	-	■	■	■
	- Fault alarm display	-	■	■	■
	- Conversion frequency display	-	-	■	■
	- Fire linkage state <sup>(2)</sup>	■	■	■	■
	- Display usage	LED	LCD	LCD	LCD
parameter setting	- Conversion delay (S)	10s <sup>(1)</sup>	0-250s	0-250s	0-250s
	- Return delay (S)	10s <sup>(1)</sup>	0-250s	0-250s	0-250s
	- Mode setting	-	■	■	■
	- Undervoltage	-	150-180	150-180	150-180
	- Overvoltage	-	220-280	220-280	220-280
Other functions	- Fire linkage input <sup>(2)</sup>	■	■	■	■
	- Communicating function	-	-	□	■

■ standard configuration   □ Optional configuration   - This function is not available

Note: (1) If you need other delay time, please contact us before ordering

(2) The three-bit bit provides this function

# MARS Automatic Transfer Switch

## AT10 Terminal PC-level Automatic Transfer Switch

### Type A Controller Terminal Wiring Diagram

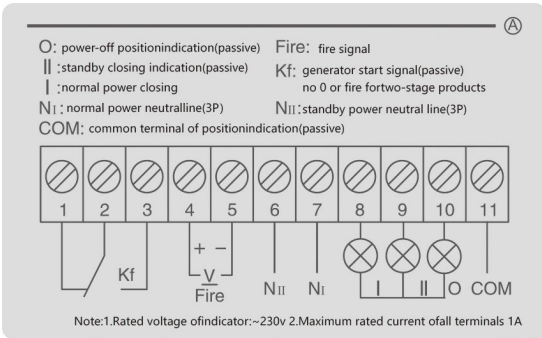

Note: 3P products must be connected to the zero line! The neutral wire of the common power supply connects to terminal 7 N, and the neutral wire of the standby power supply connects to terminal 6 Nm.

### Type B Controller Terminal Wiring Diagram

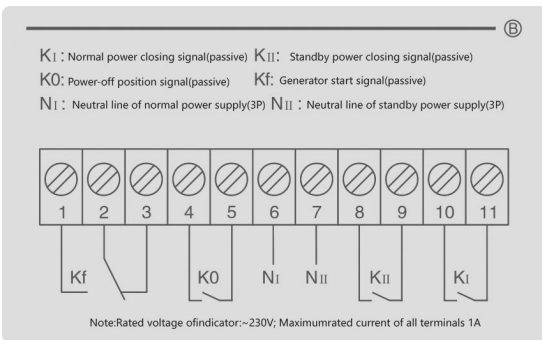

Note: 3P products must be connected to the zero line! The neutral wire of the common power supply connects to terminal 6 N, and the neutral wire of the standby power supply connects to terminal 7 Nm.

# MARS Automatic Transfer Switch

## AT10 Terminal PC-level Automatic Transfer Switch

### Type C Controller Terminal Wiring Diagram

ATSE controller					
Model: Type C	Insulation voltage: AC300V	25	485B		
Applicable products: PC grade	Installation mode: split type	26	485A		
Controller terminal wiring description (maximum 250V/500mA): 25-27: indicates a communication port 29,30: power off location indication 33,34: fire signal input 29,32: Common closing indication 29,31: standby closing indication 35-37: Generator start signal output (passive) 38-40: Common power supply fault alarm output (passive)		27	GND		
		28			
		29	COM		
		30	O		
		31	II		
		32	I		
				Gnd	33
				+24V	34
				Com1	35
				NC1	36
		NO1	37		
		Com2	38		
		NC2	39		
		NO2	40		

Note: There is no power failure position and fire signal terminal for -segment products.



Note: 3P products must be connected to the zero line! The neutral wire of the common power supply is connected to terminal 4 on the tail of the C-type controller N. The neutral wire of the standby power supply is connected to terminal 15 on the tail of the C-type controller NII.

### Type D Controller Terminal Wiring Diagram

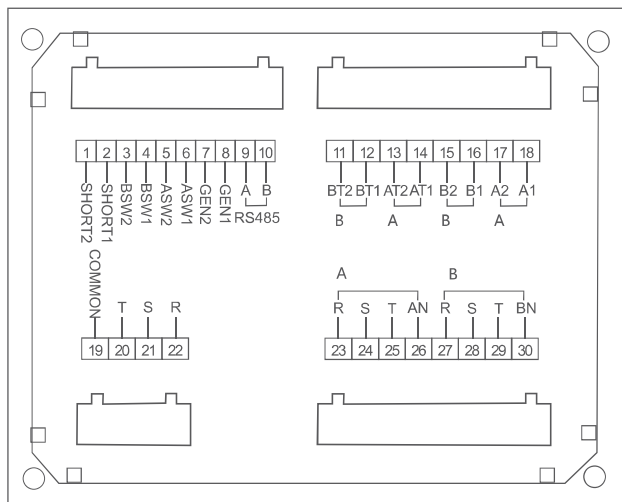

Note: SHORT2 (DC24V+), SHORT1 (DC24V-) for the fire power emergency linkage control terminal, send a signal, the switch will turn to the middle OFF position and cut off the power supply.

# MARS Automatic Transfer Switch

## AT10 Terminal PC-level Automatic Transfer Switch

### Size with Type A Controller

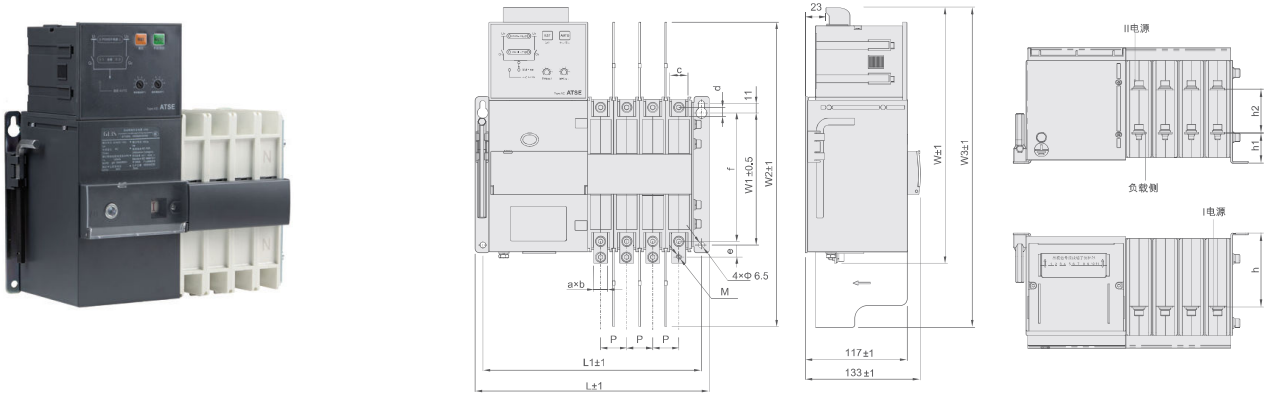

Shell frame/ pole number	Size (mm)													Installation dimension (mm)		
	L	W	W2	W3	axb	c	d	e	f	h	h1	h2	M	L1	W1	P
AT10P-63/3P	220	294.5	-	-	12x2	17.4	10.5	18	154.4	84.8	34.5	50.3	M6	202	152	22
AT10P-63/4P	243	294.5	-	-	12x2	17.4	10.5	18	154.4	84.8	34.5	50.3	M6	225	152	22
AT10P-125/3P	239	294.5	350	367	16x2	21	10.5	18	154.4	84.8	34.5	50.3	M6	221	152	30
AT10P-125/4P	269	294.5	350	367	16x2	21	10.5	18	154.4	84.8	34.5	50.3	M6	251	152	30
AT10P-250/3P	258.5	299	350	367	20x2	27.5	9.5	20.5	152	83	33	50	M8	240	152	36.5
AT10P-250/4P	295	299	350	367	20x2	27.5	9.5	20.5	152	83	33	50	M8	277	152	36.5
AT10P-400/3P	295	340	387	397.5	30x2	34	14	32	181	84	34.5	49.5	Φ10.5	272	176	45
AT10P-400/4P	337	340	387	397.5	30x2	34	14	32	181	84	34.5	49.5	Φ10.5	317	176	45

### Size with type B Controller

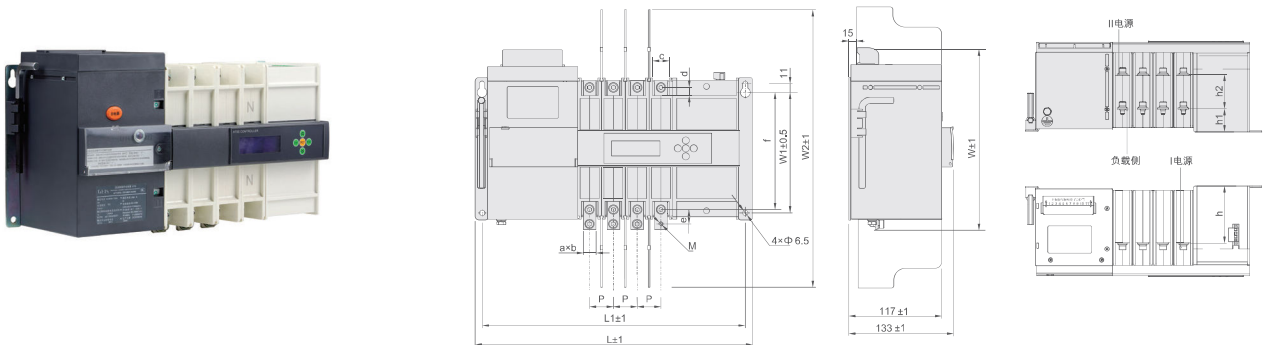

Shell frame/ pole number	Size (mm)													Installation dimension (mm)		
	L	W	W2	axb	c	d	e	f	h	h1	h2	M	L1	W1	P	
AT10P-63/3P	301	226.5	-	12x2	17.4	10.5	18	154.4	84.8	34.5	50.3	M6	283	152	22	
AT10P-63/4P	324	226.5	-	12x2	17.4	10.5	18	154.4	84.8	34.5	50.3	M6	306	152	22	
AT10P-125/3P	320	226.5	350	16x2	21	10.5	18	154.4	84.8	34.5	50.3	M6	302	152	30	
AT10P-125/4P	350	226.5	350	16x2	21	10.5	18	154.4	84.8	34.5	50.3	M6	332	152	30	
AT10P-250/3P	339.5	229.5	350	20x4	27.5	9.5	20.5	152	83	33	50	M8	321	152	36.5	
AT10P-250/4P	376	229.5	350	20x4	27.5	9.5	20.5	152	83	33	50	M8	358	152	36.5	

# MARS Automatic Transfer Switch

## AT10 Terminal PC-level Automatic Transfer Switch

### Size with type C Controller, 16-400A

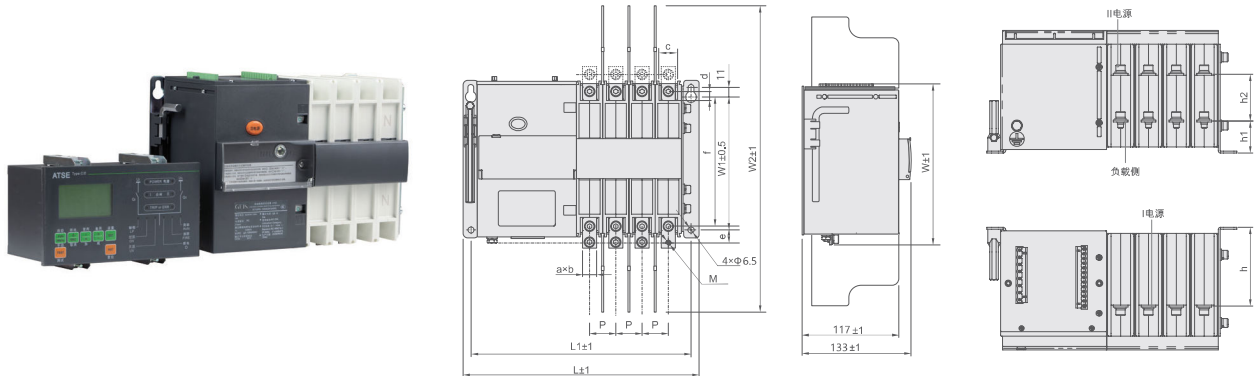

Shell frame/ pole number	Size (mm)												Installation dimension (mm)		
	L	W	W2	a×b	c	d	e	f	h	h1	h2	M	L1	W1	P
AT10P-63/3P	220	196.5	-	12x2	17.4	10.5	18	154.4	84.8	34.5	50.3	M6	202	152	22
AT10P-63/4P	243	196.5	-	12x2	17.4	10.5	18	154.4	84.8	34.5	50.3	M6	225	152	22
AT10P-125/3P	239	196.5	350	16x2	21	10.5	18	154.4	84.8	34.5	50.3	M6	221	152	30
AT10P-125/4P	269	196.5	350	16x2	21	10.5	18	154.4	84.8	34.5	50.3	M6	251	152	30
AT10P-250/3P	258.5	200	350	20x4	27.5	9.5	20.5	152	83	33	50	M8	240	152	36.5
AT10P-250/4P	295	200	350	20x4	27.5	9.5	20.5	152	83	33	50	M8	277	152	36.5
AT10P-400/3P	292	243	387	30x5	34	14	32	181	84	34.5	49.5	Φ10.5	272	176	45
AT10P-400/4P	337	243	387	30x5	34	14	32	181	84	34.5	49.5	Φ10.5	317	176	45

### Size with type C Controller, 500-800A

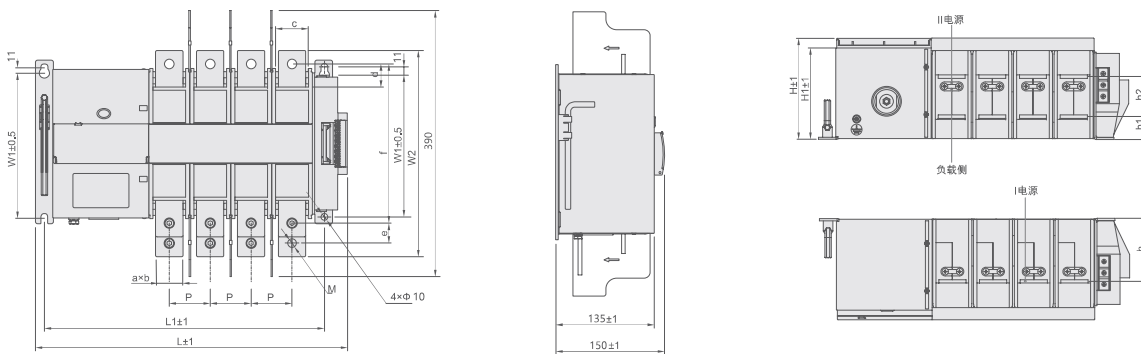

Shell frame/ pole number	Size (mm)											Installation dimension (mm)		
	L	W2	a×b	c	d	e	f	h	h1	h2	M	L1	W1	P
AT10P-800/3P	397.5	303	40x5	48	33.5	29.5	233.5	93	34	59	Φ14	350	208	60
AT10P-800/4P	457.5	303	40x5	48	33.5	29.5	233.5	93	34	59	Φ14	410	208	60

# MARS Automatic Transfer Switch

## AT10 Terminal PC-level Automatic Transfer Switch

### Size with type D Controller, 1000-1250A

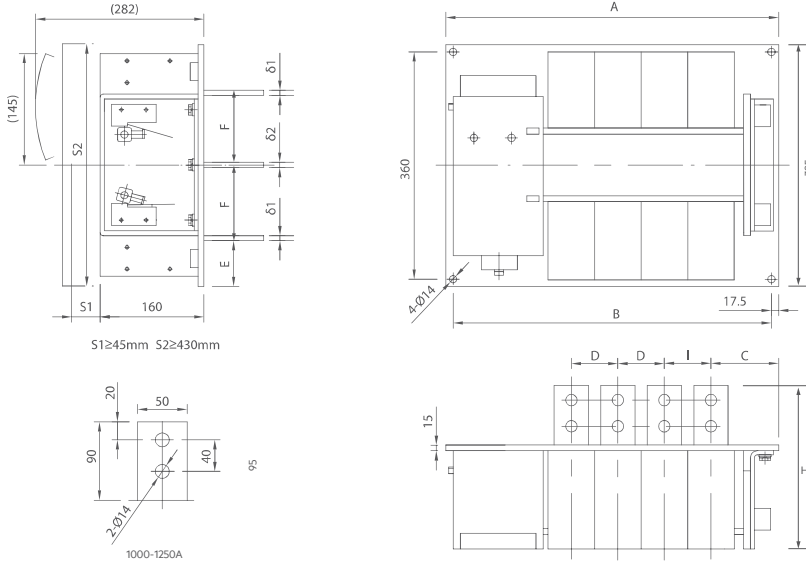

Specification	A		B		C	D	E	F	δ1	δ2	I	H
	3P	4P	3P	4P								
1000A	455	535	420	500	89	80	61.5	128.5	12	15	80	250
1250A									15			

### Size with type D Controller, 1600-2500A

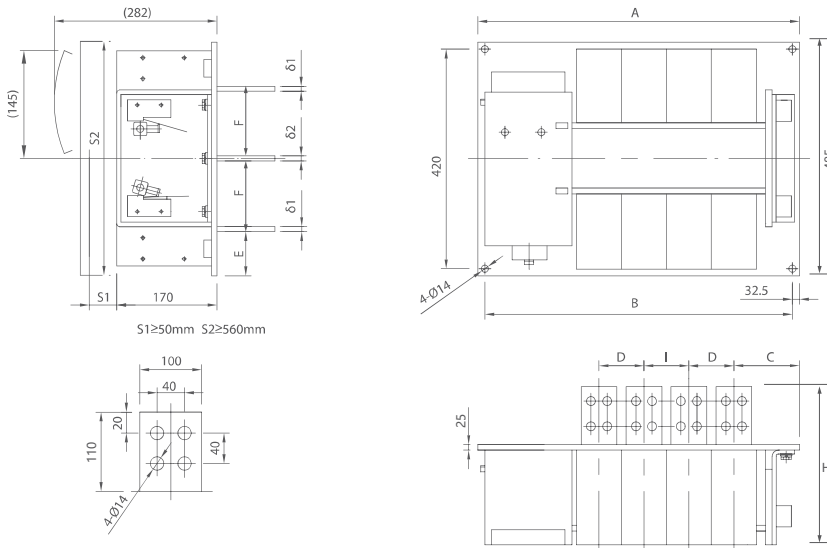

Specification	A		B		C		D	E	F	δ1	δ2	I	H
	3P	4P	3P	4P	3P	4P							
1600A	685	855	625	785	130	152	145	102	116.5	15	15	160	280
2000A								102	116.5	15	15		
2500A								97	112	20	20		

# MARS Automatic Transfer Switch

## AT10 Terminal PC-level Automatic Transfer Switch

### Size of type C Controller

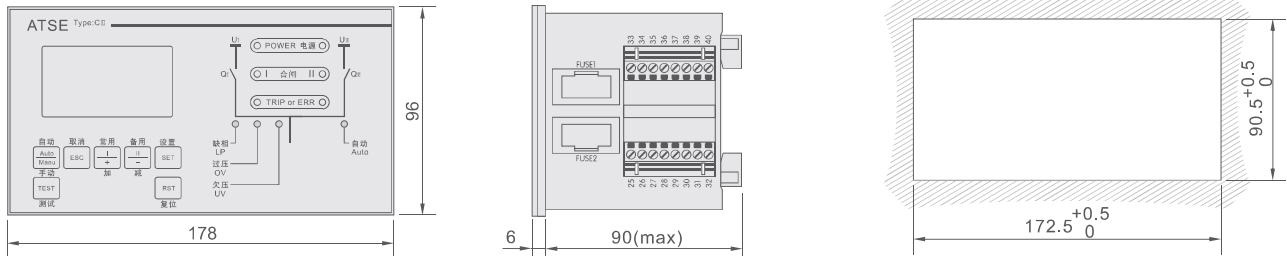

### Size of type D Controller

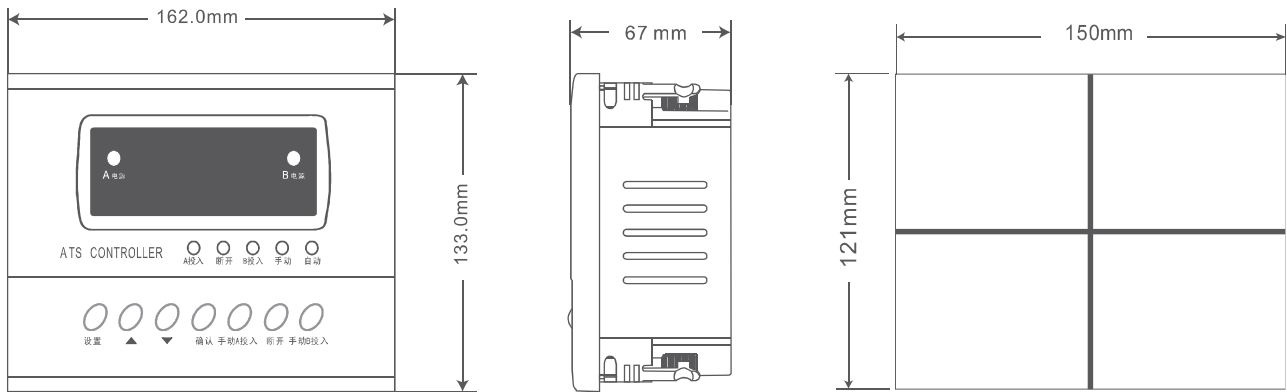

# MARS Automatic Transfer Switch

## AT10B CB-level Automatic Transfer Switch

### Overview

AT10B CB automatic switch uses GEIS micro circuit breaker or plastic-case circuit breaker as the actuator, the new silent motor drive device, bringing fast and stable conversion. It is widely used in residential, commercial, hotel applications and other end equipment power switching. Based on the technical accumulation and innovation of circuit breaker and switch equipment, AT10B series can reach the industry-leading AC-33B with excellent high breaking capacity, 3 level current limiting capacity, and can be replaced with other GEIS distribution products.



### Products

- Modular design, so the actuator and the transmission mechanism and the control unit can be quickly and independently replaced
- Gear link type mechanical interlock, the transmission is stable and reliable, eliminating the possibility of two simultaneous closing
- With overload, short circuit, over and under voltage, phase protection and other functions
- Low power consumption, peak power consumption is less than 5W
- The control unit adopts the new sampling and control mode, and the EMC performance is excellent
- Comprehensive control functions, with three-phase voltage detection, fire linkage, generator start and stop; conversion delay is field adjustable

### Executive standards

- GB14048.1
- GB14048.2
- GB10963.1
- GB14048.11

### Conditions of Use

- Working temperature: -10°C ~45°C
- Storage temperature: -25°C ~55°C
- Ambient humidity: When the maximum temperature is +40°C, the relative humidity of the air does not exceed 50%; When the average temperature is +25°C, the humidity does not exceed 90%;
- Altitude: Not more than 2000m
- Pollution level: Class III

### Model Description

<b>AT10</b>	<b>B</b>	-	<b>63</b>	/	<b>4</b>	<b>B</b>
<b>Product series</b>	<b>Transfer switch type</b>		<b>Rated current</b>		<b>Poles</b>	<b>controller</b>
AT10 automatic transfer switch	B: CB		16-16A ..... 63-63A ..... 630-630A		3-3 poles 4-4 poles	B-B

Note: 1. A6 series MCCB as actuator for 63A and below, Z6 series MCCB as actuator for 80-630A  
 2. Type B controller is used for plastic-case products.  
 3. Contact GEIS for special requirements

# MARS Automatic Transfer Switch

## AT10B CB-level Automatic Transfer Switch

### Performance Parameters

Specification and model		AT10P-63		AT10P-125		AT10P-250		AT10P-800	
Rated operating current (A) $I_e^{(1)}$		16-63		80-125		160-250		300-400	500-800
Rated operating voltage (U) $U_e$		AC 400		AC 400		AC 400		AC 400	
Rated insulation voltage (V) $U_i$		800		800		800		800	
Rated impulse Withstand Voltage (kV) $U_{imp}$		8		8		8		8	
Rated frequency (Hz)		50/60		50/60		50/60		50/60	
Poles (P)		3, 4		3, 4		3, 4		3, 4	
Operating current (A)	110V AC/DC	6		8		8		12	16
	220V AC/DC	3		4		4		6	8
Trip Current (A)	110V AC/DC	1.4		1.4		1.4		2	2.4
	220V AC/DC	0.7		0.7		0.7		1	1.2
I <sub>q</sub> (kA)	Reachable value when protected by circuit breaker	35		50		50		65	65
	The value can be reached when protected by a fuse	100		120		120		120	120
Making and breaking ability $\cos\phi=0.45$		10I <sub>e</sub>		10I <sub>e</sub>		10I <sub>e</sub>		10I <sub>e</sub>	10I <sub>e</sub>
Service life (times)	- Electric	6000		6000		6000		6000	6000
	- Mechanical	10000		10000		10000		10000	10000
Off time (s)	II < 0.2	II < 0.2		II < 0.2		II < 0.2		-	-
	III < 0.7	III < 0.7		III < 0.7		III < 0.7		III < 0.7	III < 1.2
mode of connection	Front wiring	■		■		■		■	■
Appliance level		PC		PC		PC		PC	PC
Utilization category		AC-33A		AC-33B		AC-33B		AC-33B	AC-33B
Number of main contact positions		two-tier	three-tier	two-tier	three-tier	two-tier	three-tier	three-tier	three-tier
Controller	A	□	□	□	□	□	□	-	-
	B	□	□	□	□	□	□	-	-
	C	□	□	□	□	□	□	■	■
Meet the criteria		GB/T 14048.11, IEC 60947-6-1							

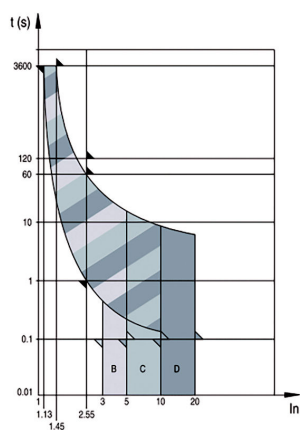

t=30°C



# MARS Automatic Transfer Switch

## Trip time - current characteristic

### Short-circuit protection

Trip type	Drop-away current	Drop-away time
D	10-20I <sub>n</sub>	≤100ms

### Overload protection

Rated current	Drop-away current	Drop-away time
≤63A	≤1.13I <sub>n</sub>	Non-trip within 1h (cold)
	≤1.45I <sub>n</sub>	Trip within 1h (hot)

## ATS size, 16-63A

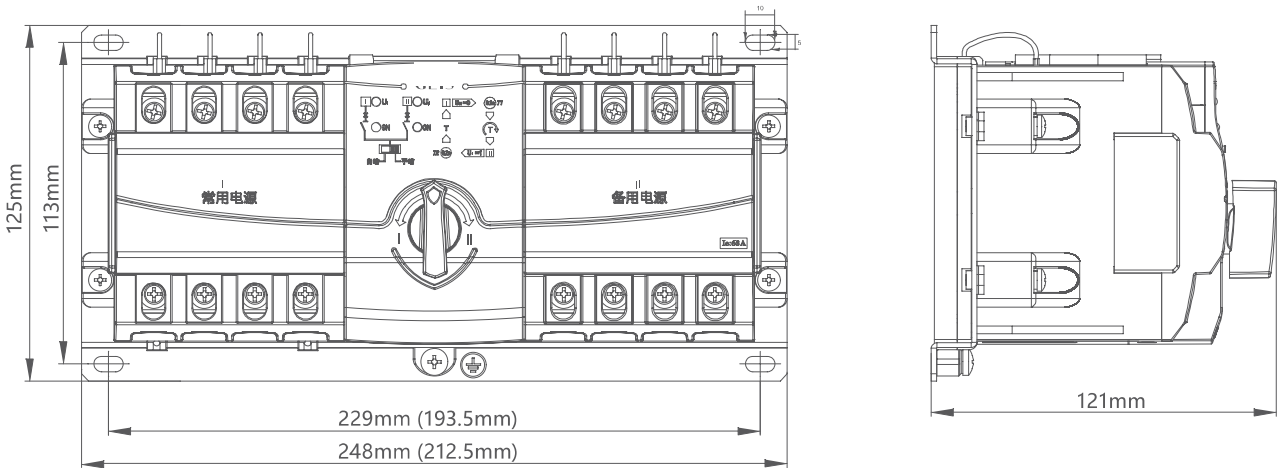

Note: 3-pole product dimensions in parentheses

# MARS Automatic Transfer Switch

**ATS size, 80-630A**

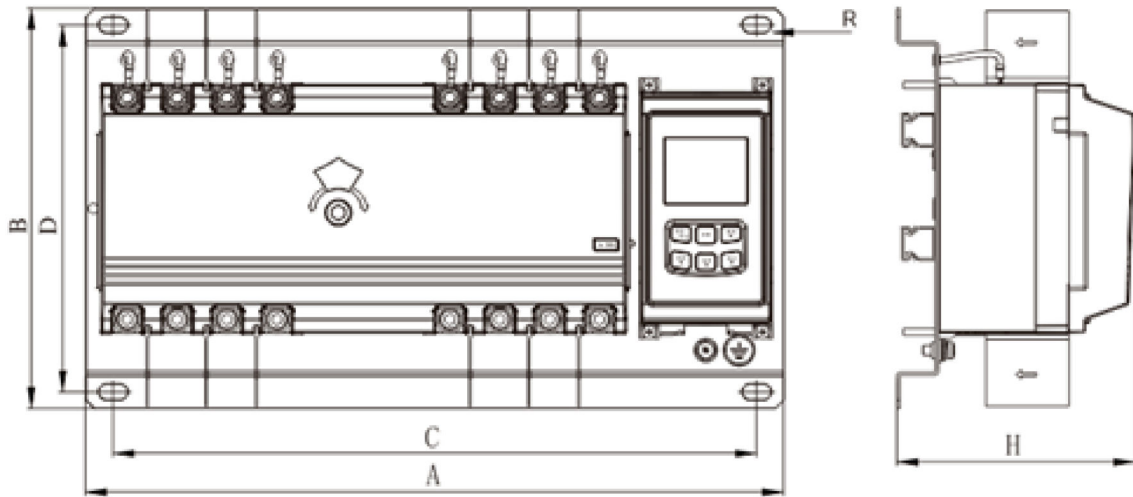

Model	A		B	C		D	H	R
	3P	4P		3P	4P			
AT10B-125	390	420	240	357	387	220	145	φ9
AT10B-250	435	470	240	402	437	220	145	
AT10B-400	565	615	330	505	555	300	200	φ11
AT10B-630	682	740	330	622	680	300	200	



# GEIS

GEIS Electric

Website: [www.geis.tech](http://www.geis.tech)

Hotline: +86 400-820-5234

This catalog may be subjected to revision without prior notice.  
Version No.: GENCCPAA26V2

