

GEIS

M-PACT

Air circuit breaker

GEIS Electrical Protection

Safer Smarter Greener



About GEIS

GEIS was established in 2019 following the spin-off of several businesses and assets that ABB had acquired from GE on July 1, 2018, including 3 manufacturing centers, Warehousing & Trading business at FTZ, China Technology Center.

- Components: Full range of circuit breakers up to 40.5kV: Medium voltage vacuum circuit breakers, LV circuit breakers: ACB, MCCB, MCB, RCD, RCBO: Control components.
- Equipment: MV switchgear (Air insulation and Gas Insulation Technology), LV switchgear, switchboard.
- Medium voltage distribution transformer.
- Medium voltage ATS system (Paralleling Switchgear).

After the separation, all the above product lines were rebranded as AEG for selected markets and GEIS for global markets. Moreover, GEIS has expanded its technological portfolio to include medium-voltage controls such as VFDs and soft starters, as well as ATS systems and EV chargers.



Quality is Built-in

Where Technology Meets Manufacturing Excellence for Customers

- Since 2000, we have been specializing in localizing world-class products and manufacturing technologies, developing strong expertise and a highly capable team.
- Vertical integrated Shanghai Manufacturing Center brought key manufacturing processes into a 75,000 m² facility, enabling high-quality, high-efficiency production and fostering innovation. A dedicated R&D team committed to developing products that meet global standards and serve diverse applications.
- Global expansion: GEIS's first Thailand facility makes it easier to serve customers worldwide.



GEIS deliver complete range of products for the evolving electrification needs:



SecoVac VCB



M-PACT Plus ACB



Elfa Series MCB/RCBO



SolidDrive MV VFD



SecoGear MV Switchgear



RMU Gas Insulated Switchgear



WaveCast Transformer



MLS LV Switchgear



A

Rated from 400 to 4000A the M-PACT circuit breaker has been designed to meet the most stringent demands in fault detection and safe interruption thereof.

Available in 4 frame sizes:

- frame size 0 ranging from 400 to 1600A
- frame size 1 ranging from 400 to 2500A
- frame size 2 ranging from 800 to 4000A
- frame size 3 ranging from 5000 to 6400A

The range has been developed to be aesthetically and technically coordinated with other protective devices within the GEIS product ranges.

The breaker range has a common height and depth and is available in both fixed pattern and drawout versions which can be manually or electrically operated.

Designed to offer multiple mains connection options it also comes with a wide range of easy-to-install accessories.

B

C

Specification

M-PACT air circuit breakers comply with the following specifications for Low Voltage Switchgear:

IEC 60947-1

IEC 60947-2

IEC 60947-3

Utilisation category B

Approvals

KEMA certification in accordance with IEC 60947-2,

CCC certification in accordance with GB14048-2

5 performance ranges *415VAC

A - 50kA (Icu); N - 65kA (Icu), Frame 0

D - 70kA (Icu); H1,H2 - 80kA (Icu)

M - 100kA (Icu); L - 150kA (Icu)

4 compact frame sizes

Frame size 0 - 400 to 1600A

Frame size 1 - 400 to 2500A

Frame size 2 - 800 to 4000A

Frame size 3 - 5000 to 6400A

Fixed pattern and withdrawable versions

3 or 4 pole versions

Front and rear access connections (horizontal/vertical)

Devices provided with or without protection relay

Manual or electrical operation

Built-in safety features e.g. safety shutters

Wide range of protection settings offering full selectivity

Combinations of earth fault protection

Easy-to-install accessories, common to entire range

Simple and efficient servicing on site

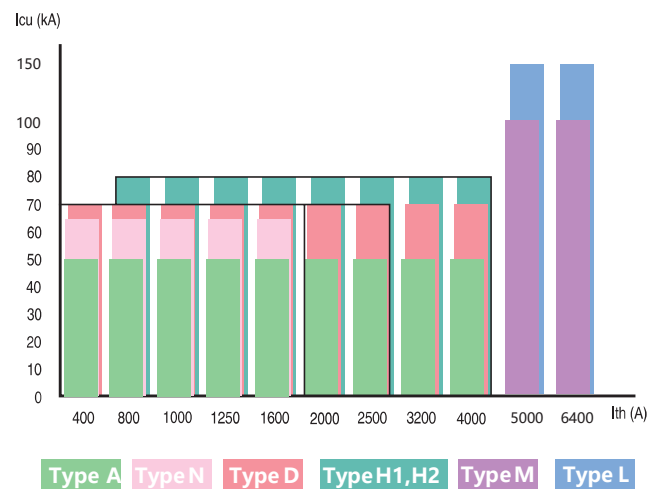

Air circuit breaker 400A-6400A

Technical data

Order codes

- A.2 Fixed circuit breakers
- A.5 Withdrawable circuit breakers
- A.6 Characteristics
- A.8 Mpro control unit
- A.34 Accessories

Wiring diagrams -
Dimensional drawings

A

B

C

A

B

C

Characteristics

Performance data																		
Rated current (40°C)				400		800			1000				1250					
Endurance (No. of operating cycles)																		
Mechanical (with maintenance)				40000		40000 25000			40000 25000				40000 25000					
Mechanical (without maintenance)				25000		25000 15000			25000 15000				25000 15000					
Electrical (at rated current)				10000		10000 10000			10000 10000				10000 10000					
Rated service voltage (50/60 Hz)		Ue	V	690		690			690				690					
Rated insulation voltage		Ui	V	1000		1000			1000				1000					
Rated impulse withstand voltage		Uimp	V	12000		12000 12000			12000 12000				12000 12000					
Number of poles				3 & 4		3 & 4			3 & 4				3 & 4					
Rating of 4th pole				100%		100%			100%				100%					
Breaking Code				A	D	A	D	H1	H2	A	D	H1	H2	A	D	H1	H2	
Frame size				1	1	1	1	2	2	1	1	2	2	1	1	2	2	
Rated ultimate short-circuit		Icu	kA (rms)	220V	50	70	50	70	80	80	50	70	80	80	50	70	80	80
Breaking capacity				415V	50	70	50	70	80	80	50	70	80	80	50	70	80	80
				500V	-	50	-	50	-	80	-	50	-	80	-	50	-	80
				600V	-	50	-	50	-	65	-	50	-	65	-	50	-	65
				690V	-	50	-	50	-	65	-	50	-	65	-	50	-	65
Rated service short-circuit		Ics	kA (rms)	220V	50	65	50	65	80	80	50	65	80	80	50	65	80	80
Breaking capacity				415V	50	65	50	65	80	80	50	65	80	80	50	65	80	80
				500V	-	50	-	50	-	80	-	50	-	80	-	50	-	80
				600V	-	50	-	50	-	65	-	50	-	65	-	50	-	65
				690V	-	50	-	50	-	65	-	50	-	65	-	50	-	65
Rated short time withstand current																		
1 second		Icw 415/690VAc	kA (rms)		50	65/50	50	65/50	65	80	50	65/50	65	80	50	65/50	65	80
3 seconds		Icw	kA (rms)		-	50	-	50	-	-	-	50	-	-	-	50	-	-
Rated short-circuit making capacity		Icm	kA (peak)	415V	105	143	105	143	176	176	105	143	176	176	105	143	176	176
				500V	-	143	-	143	-	176	-	143	-	176	-	143	-	176
				600V	-	105	-	105	-	143	-	105	-	143	-	105	-	143
				690V	-	84	-	84	-	105	-	84	-	105	-	84	-	105
Power consumption (Fixed)			W		15	10	63	43	23	20	106	68	36	32	175	105	60	53
Power consumption (Draw out)			W		30	21	127	86	49	43	211	135	77	68	351	211	128	113

Note1: Design and specifications are subject to changes without notice. AC500V/600V/690V breaking capacity, please contact us.

Note2: Frame 1, working voltage at 690V, short-circuit breaking capacity of 65kA, breaking code D2

Note3: Circuit breaker opening time ≤30ms; Closing time ≤60ms

Note4: The arcing distance of the circuit breaker is 0

Selectivity

The following table shows the conditions to satisfy full selectivity between UP-STREAM and DOWN-STREAM devices.

Up-stream: M-PACT

Down-stream: M-PACT

ST delay 50 ms minimum between up-stream and downstream ACB

Multiplication coefficient between LT-ratings ≥ 1,56

	Down-stream									
	-	400	800	1000	1250	1600	2000	2500	3200	4000
Up-stream	400	-	-	-	-	-	-	-	-	-
	800	Full	-	-	-	-	-	-	-	-
	1000	Full	-	-	-	-	-	-	-	-
	1250	Full	Full	-	-	-	-	-	-	-
	1600	Full	Full	Full	-	-	-	-	-	-
	2000	Full	Full	Full	Full	-	-	-	-	-
	2500	Full	Full	Full	Full	Full	Full	-	-	-
	3200	Full	Full	Full	Full	Full	Full	Full	-	-
	4000	Full	Full	Full	Full	Full	Full	2000	Full	-

Temperature Deratings

Free Air^(D)

The M-PACT ACBs may operate at higher ambient temperatures than 40°C in certain installation conditions.

In this case the current rating in Amperes should be reduced as indicated below.

Ambient Temperature	Current Rating (A)							
	800	1000	1250	1600	2000	2500	3200	4000
50°C	800	1000	1250	1600	2000	2450	3200	3727
60°C	800	1000	1250	1445	2000	2232	3200	3367
65°C	800	1000	1250	1364	2000	2092	3019	3175
70°C	800	1000	1250	1280	1970	1970	2831	2978

The figures specified apply to withdrawable ACB's with flat face vertical copper connections

(1) Protection degree IP00. For use in enclosures with interior temperatures of 40° to 70° the relevant IP values can be applied.

		1600		2000				2500				3200				4000					
		40000		25000		40000		25000		40000		25000		25000		25000					
		25000		15000		25000		15000		25000		15000		15000		15000					
		10000		10000		8000		8000		8000		8000		7000		7000		6000		6000	
		690		690		690		690		690		690		690		690					
		1000		1000		1000		1000		1000		1000		1000		1000					
		12000		12000		12000		12000		12000		12000		12000		12000					
		3 & 4		3 & 4		3 & 4		3 & 4		3 & 4		3 & 4		3 & 4		3 & 4					
		100%		100%		100%		100%		100%		100%		100%		100%					
		A	D	H1	H2	A	D	H1	H2	A	D	H1	H2	A	D	H1	H2				
		1	1	2	2	1	1	2	2	1	1	2	2	2	2	2	2				
		50	70	80	80	50	70	80	80	50	70	80	80	50	70	80	80	50	70	80	80
		50	70	80	80	50	70	80	80	50	70	80	80	50	70	80	80	50	70	80	80
		-	50	-	80	-	50	-	80	-	50	-	80	-	-	-	80	-	-	-	80
		-	50	-	65	-	50	-	65	-	50	-	65	-	-	-	65	-	-	-	65
		-	50	-	65	-	50	-	65	-	50	-	65	-	-	-	65	-	-	-	65
		50	65	80	80	50	65	80	80	50	65	80	80	50	65	80	80	50	65	80	80
		50	65	80	80	50	65	80	80	50	65	80	80	50	65	80	80	50	65	80	80
		-	50	-	80	-	50	-	80	-	50	-	80	-	-	-	80	-	-	-	80
		-	50	-	65	-	50	-	65	-	50	-	65	-	-	-	65	-	-	-	65
		-	50	-	65	-	50	-	65	-	50	-	65	-	-	-	65	-	-	-	65
		50	65	65	80	50	65	65	80	50	65	65	80	50	65	65	80	50	65	65	80
		-	50	-	-	-	50	-	-	-	50	-	-	-	-	-	-	-	-	-	-
		105	143	143	176	105	143	176	176	105	143	176	176	105	143	176	176	105	143	176	176
		-	143	-	143	-	143	-	176	-	143	-	176	-	-	-	176	-	-	-	176
		-	105	-	105	-	105	-	143	-	105	-	143	-	-	-	143	-	-	-	143
		-	84	-	84	-	84	-	105	-	84	-	105	-	-	-	105	-	-	-	105
		284	284	196	98	86	224	163	143	351	351	255	223	418	418	418	366	571	571	571	571
		574	574	392	209	184	490	347	306	765	765	542	478	888	888	888	783	1224	1224	1224	1224

Catalogue Number Configuration

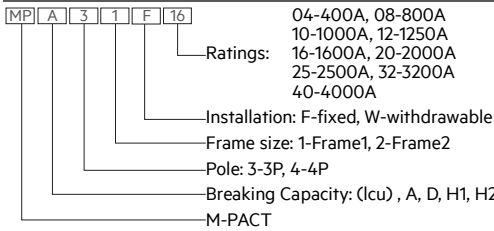

For example, the user requires a 1600A, 3-pole, withdrawable, Frame 1, Icu=70kA
The product number should be MPD31W16

Note: Frame 1, working voltage at 690V, a short-circuit breaking capacity of 65kA, breaking code is D2

Dimensions in mm

Frame Size	Rating (A)	Poles	Type	Height ⁽¹⁾	Width	Depth ⁽²⁾
1	400 to 2500	3	Withdrawable	440	329	422
			Fixed	430	342	352
		4	Withdrawable	440	429	422
			Fixed	430	442	352
2	800 to 4000	3	Withdrawable	440	419	424
			Fixed	430	432	352
		4	Withdrawable	440	549	424
			Fixed	430	562	352

(1) Height is from mounting surface to highest part of the ACB.

(2) Depth is from the cubicle door to the back of terminals.

* 4P, Neutral on the left or right Please specify on selection form, the default option is Neutral on right.

Recommended Minimum Copper Size

In accordance with IEC 60947-2

Rating (A)	Copper / phase
400	2 x 50 x 5
800	2 x 50 x 5
1000	2 x 60 x 5
1250	2 x 100 x 5
1600	2 x 100 x 5
2000	3 x 100 x 5
2500	4 x 100 x 5
3200	4 x 100 x 10
4000	4 x 100 x 10 + 1 x 100 x 5

Weights (kg)

Fixed pattern	Frame	S range		N range		H range	
		3 Pole	4 Pole	3 Pole	4 Pole	3 Pole	4 Pole
400 to 1600A	1	39	49	39	49	/	/
2000 to 2500A	1	43	54	43	54	/	/
800 to 3200A	2	53	68	53	68	53	68
4000A	2	53	68	53	68	53	68
Withdrawable	Frame	3 Pole	4 Pole	3 Pole	4 Pole	3 Pole	4 Pole
400 to 1600A	1	68	79	68	79	/	/
2000 to 2500A	1	74	85	74	85	/	/
800 to 3200A	2	90	109	90	109	90	109
4000A	2	113	128	113	128	113	128

Characteristics, 5000-6400A, Frame 3

A

B

C

Performance data							
Rated current (40°C)				5000		6400	
Endurance (No. of operating cycles)							
Mechanical (with maintenance)				20000	20000	20000	20000
Mechanical (without maintenance)				12500	12500	12500	12500
Electrical (at rated current)				8000	8000	6000	6000
Rated service voltage (50/60 Hz)	Ue	V		690		690	
Rated insulation voltage	Ui	V		1250		1250	
Rated impulse withstand voltage	Uimp	V		12000	12000	12000	12000
Number of poles				3 & 4		3 & 4	
Rating of 4th pole				100%		100%	
Breaking Code				M	L	M	L
Frame size				3	3	3	3
Rated ultimate short-circuit	l _{cu}	kA (rms)	220V	100	150	100	150
Breaking capacity			415V	100	150	100	150
			500V	100	100	100	100
			600V	100	100	100	100
			690V	100	100	100	100
Rated service short-circuit	l _{cs}	kA (rms)	220V	100	150	100	150
Breaking capacity			415V	100	150	100	150
			500V	100	100	100	100
			600V	100	100	100	100
			690V	100	100	100	100
Rated short time withstand current							
1 second	l _{cw} 415/690V Ac	kA (rms)		100	100	100	100
3 seconds	l _{cw}	kA (rms)		85	85	85	85
Rated short-circuit making capacity	l _{cm}	kA (peak)	415V	220	330	220	330
			500V	220	220	220	220
			600V	220	220	220	220
			690V	220	220	220	220
Power consumption (Fixed)		W		163	163	266	266
Power consumption (withdrawable)		W		260	260	426	426

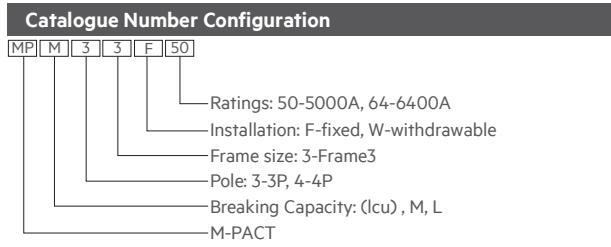

For example, the user requires a 5000A, 3P, withdrawable, Frame 3, l_{cu}=100kA, The product number should be: MPM33W50

Dimensions in mm						
Frame Size	Rating (A)	Poles	Type	Height	Width	Depth
3	5000 to 6400	3	Withdrawable	443	743	522
			Fixed	442	736	355
		4	Withdrawable	443	943	522
			Fixed	442	966	355

Weights (kg)			
	Frame	M/L	
		3P	4P
Fixed ACB	3	141	153
Withdrawable ACB	3	291	313

Temperature Deratings

Free Air⁽¹⁾
 The M-PACT ACBs may operate at higher ambient temperatures than 40°C in certain installation conditions. In this case the current rating in Amperes should be reduced as indicated below.

Rating (A)	Ambient Temperature				
	≤50°C	55°C	60°C	65°C	70°C
5000	5000	5000	5000	4900	4800
6400	6400	6300	6200	6100	6000

(1) Protection degree IP00. For use in enclosures with interior temperatures of 40° to 70° the relevant IP values can be applied.

Recommended Minimum Copper Size

In accordance with IEC 60947-2

Rating (A)	Copper / phase; mm
5000	5 x 120 x 10 or 6 x 100 x 10
6400	7 x 120 x 10 or 8 x 100 x 10

Note: 6400A, when applied in horizontal wiring, it is recommended to either increase the cross-section of the connecting busbar, enhance cooling measures, or derate the usage

Fixed Circuit Breaker

All M-PACT fixed pattern air circuit breakers incorporate a stored energy mechanism. The spring can be charged either manually or electrically via a motor operator that is automatically activated after the closing operation. IP43 front panel and door escutcheon seals are standard features with IP20 protected secondary isolating contacts. For enhanced protection, an optional IP54 door panel is also available.



8
9

- Trip-free operating mechanism
- Positive 'ON/OFF' contact indication
- Mechanical/electrical anti-pumping device
- Charging spring status indication (optional)
- Ergonomic manual spring charging handle
- Field-mountable range of accessories
- Auxiliary switches 5 NO and 3 NC, 10A 250V (standard)
- Padlockable push-button cover
- Mechanical cable interlocking (optional)
- Termination: rear, horizontal or front access (optional)
- Electrical clearances according to IEC 60947-2
- Front access of secondary terminals for simple connection
- Mechanical trip alarm switch (1NO) (optional)

Installation

Fixed pattern M-PACT Plus can be fastened into any suitable switchboard or cubicle arrangement using four M8 bolts. Clearance is only required above the unit for the removal and inspection of the arc chutes (see dimensional drawings for mounting details and recommended clearance distances). An earthing point is provided on either side of the circuit breaker.

Power Supply

All stated short circuit ratings are certified with incoming supply connection made to either upper or lower terminals..



3 4 5 6

2

7

10

11

12

1

- 1.Motorised spring charging unit (optional)
- 2.M-PRO Control Unit (optional)
- 3.Secondary contacts
- 4.Shunt trip (optional)
- 5.Closing coil (optional)
- 6.Undervoltage release (optional)
- 7.Manual charging handle
- 8.ON/OFF push-buttons
- 9.Push-button padlockable covers
- 10.Positive contact indication
- 11.Charging spring status indication
- 12.Mounting plate

A

Withdrawable Circuit Breaker

Pre-mounted into a self-contained 'cassette', this versatile circuit breaker can be inserted or withdrawn via sliding rails using a racking drive mechanism controlled by a racking handle. It provides three set positions: Disconnected / Test / Connected.

Any attempt to withdraw the unit whilst in service will automatically trip the breaker, either by the racking position safety mechanism or by the insertion of the racking handle. It can be racked to the disconnected position with the cubicle door closed or open.



- Insulated, earthed steel shutters to isolate the main contact zone
- Front access padlocking for safety shutters
- Secure padlocking in the "Disconnect" position
- Clearly visible operational position indication
- Carriage position switch (optional)
- Termination: Flat copper palms (standard) with captive M10 fixing nuts
- T' terminal adaptors for horizontal/vertical connection (optional)
- Front access connections (optional)
- Automatic disconnect of secondary circuits
- Lifting lugs for ease of removing the circuit breaker from the cassette
- Front access of secondary terminals for simple connection
- Cassette side mounting fixing parts (optional)

Installation

Circuit breakers are delivered pre-mounted in the cassette (standard)

Versatile fixing arrangements allow mounting onto any switchboard or cubicle using four M8 bolts (see dimensional drawings for mounting details and recommended clearance distances)

Earthing point situated on the right hand side of cassette (front view)

Power Supply

All stated short circuit ratings are certified with incoming supply connection made to either upper or lower terminals.

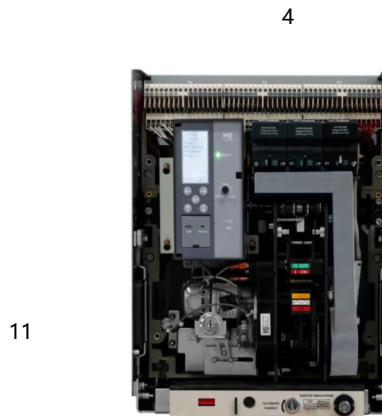

11

4

10 9

4



3

2

1

5

8 7 6

1. Carriage position switch (optional)
2. Extension rail
3. Earthed steel safety shutter
4. Secondary terminals
5. 2 way cable interlock mechanism (optional)
6. Racking handle (storage)
7. Padlocking for safety shutters
8. Insertion hole for racking handle
9. Padlocking in the DISCONNECTED position
10. Operational position indication
11. Key interlock (optional)

Circuit Breaker, Frame 3

Appearance

All circuit breakers are equipped with energy storage mechanisms. The energy storage of the spring can be done manually or by an electric motor. The front panel protection level is IP43, and for better protection, an IP54 front face mask can also be selected.



Cover of ACB

1. Internal accessory indicator window
2. Control unit
3. Manual charging handle
4. ON/OFF push-buttons
5. Contact Position Indicator
6. Ready to Close Indicator
7. Spring charged Indicator
8. Operation Counter
9. Lock for OFF position

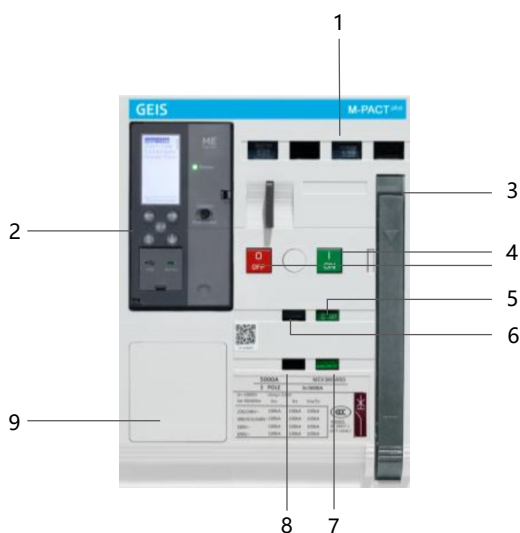

Nameplate of Circuit breaker

1. Product name
2. Rated voltage
3. Rated current
4. Certificate and Standard
5. Breaking Capacity

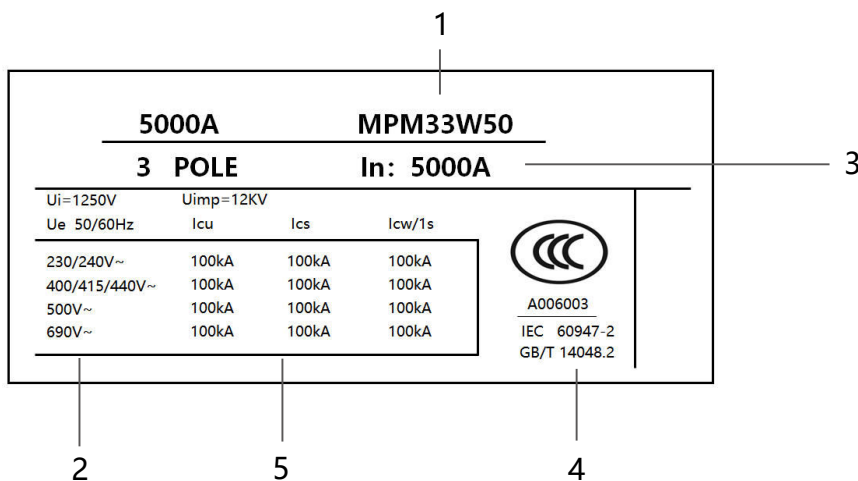

Mpro Intelligent control unit



New generation advanced intelligent control unit

M-PACT offers a full range of air circuit breakers, including the new generation Mpro digital control units Mpro21/22, Mpro31/32, and Mpro41/42. Featuring a unified LCD display design, providing electrical parameters such as current, convenient and accurate function menu keyboard, and a wide range of parameter and current settings.

All function menu settings can be achieved through four setting buttons and one confirmation button, allowing for quick and accurate parameter settings of the device. Users can easily choose between manual or automatic fault reset on the panel.

When the external power module is not powered on, the control unit can also be activated through an external test module with a battery.

Main adjustable options

I_r- Overload long-time protection

Overload long-time protection setting (I_r), adjustable from 0.2-1 I_n, with a step size of 0.1 * I_n or 1A. The setting range for Overload long-time tripping time is 0-24s, which can meet the overload protection requirements of different lower level loads.

I_{sd}-Short circuit delay protection

The short-circuit short delay protection setting can be adjusted from 1.5-10 I_r (long delay setting value), with a step size of 0.5 * I_r or 1A. Short circuit short delay T_{sd} provides two methods: fixed time and inverse time, with a set time of 0-0.4s

I_i -Short circuit instantaneous protection

The short-circuit instantaneous protection setting can be adjusted from 2-15I_n, with a step size of 1 * I_n or 1A. The short-circuit instantaneous protection is set to ensure that the lower pole circuit breaker opens first.

Other protective features

Other optional protection functions include RELT, ground protection of vector sum, independent ground CT protection, voltage protection, frequency protection, power protection, etc. Please refer to the control unit function page of the catalogue for details.

Parameter measurement, relay and communication functions

The control unit can provide Modbus RTU communication function, capturing and recording overload, short circuit, ground tripping events and other functions.

A

B

C

CURRENT
VOLTAGE
POWER
PWR LONG TIME
PWR SHORT TIME
FREQ INST
PHAS GF SUM
GF CT TRIPS
GF PRI ALARMS
MCR EVENTS
HSIOC COUNTER
RELT CONTACT WEAR
NEUT CLR HISTORY
IU
LANGUAGE
FREQUENCY
ADVANCED
CURVE TEST
DATE TIME
TUS>
SYSTEM >

The M-PACT series of circuit breakers can be configured with three basic types of digital electronic control units: Mpro21/22, Mpro31/32, and Mpro41/42. Each basic type of control unit has the same appearance design, a wide rated current setting range (0.2-1In), and a simple and accurate circuit breaker parameter setting menu.

Mpro21/22, Mpro31/32 control units provide ammeter function.

Mpro41/42 control unit provides current, voltage, power, and frequency measurement functions.

By using 4 setting keys and one confirmation key, it is convenient and accurate to set the function menu of the control unit

Before the device is powered on, the control unit can be activated through a power module with a standard configuration of a circuit breaker. During the normal operation of the control unit, power is supplied through the built-in induction coil of the circuit breaker or an external auxiliary power module. When there is no external power supply, the control unit is activated when the circuit breaker is loaded and the load current reaches 20% of the rated current of the circuit breaker.

In the absence of power, the internal battery of the Mpro control unit can also supply power to the control unit. When the "left/return" button on the control unit is pressed, the internal battery will activate the control unit and maintain the LCD on for 10 seconds after the button is released. After the control unit is activated, customers are allowed to set basic parameters, browse ammeters, and record events for the control unit.

It can also be connected to a DC 5V power supply through a USB interface to supply power to the control unit, and parameters can be set and read by connecting to the HMI.



Mpro Basic protection Functions

Technical data

		Mpro21	Mpro22	Mpro31	Mpro32	Mpro41	Mpro42	Default
Display	LCD	●	●	●	●	●	●	
	Touch key	-	-	-	-	-	-	
	langue, Chinese/English	●	●	●	●	●	●	chinese
	Trip reset auto/manual	●	●	●	●	●	●	
Overload long time protection, Ir	Select from 0.2-1In, step 1A	●	●	●	●	●	●	1xIn
	Trip time form 0.5-24s, step 0.1s	●	●	●	●	●	●	4s
	State setting, Close/Trip	●	●	●	●	●	●	Trip
Short circuit delay protection, Isd	Select from 1.5-10Ir, step 1A	●	●	●	●	●	●	1.5xIn
	Trip time Tsd (I ² T ON) form 0.1-0.4s step 0.1s	●	●	●	●	●	●	
	Trip time Tsd (I ² T OFF) form 0.1-0.4s step 0.1s	●	●	●	●	●	●	0.1s
Instantaneous protection, Ii	State setting, Close/Trip	●	●	●	●	●	●	Trip
	Select from 2-15In, step 1A	●	●	●	●	●	●	2xIn
Ground Sum protection, Ig	State setting, Close/Trip/alarm	-	●	-	●	-	●	Close
	Select from 0.2-1In, step 1A	-	●	-	●	-	●	0.2xIn
	Trip time Tsd (I ² T ON) form 0.1-0.4s step 0.1s	-	●	-	●	-	●	0.1s
	Trip time Tsd (I ² T OFF) form 0.1-0.4s step 0.1s	-	●	-	●	-	●	0.1s
Ground CT protection	State setting, Close/Trip/alarm	-	●	-	●	-	●	Close
	Select from 0.2-1In, step 1A	-	●	-	●	-	●	0.2xIn
	Trip time Tsd (I ² T ON) form 0.1-0.4s step 0.1s	-	●	-	●	-	●	0.1s
	Trip time Tsd (I ² T OFF) form 0.1-0.4s step 0.1s	-	●	-	●	-	●	0.1s
Ground fault Pre-alarm	State setting, Close/GFSUM/GFCT	-	●	-	●	-	●	Close
	Select from 120-1200A, step 1A	-	●	-	●	-	●	200A
	Pre-alarm time from 1-10s, step 0.1s	-	●	-	●	-	●	10
	Return value select from 120-1200A, step 1A	-	●	-	●	-	●	120A
	Return time form 1-10s, step 0.1s	-	●	-	●	-	●	10
Neutral protection	State setting, Close/Trip	●	●	●	●	●	●	Trip
	Neutral phase value, OFF or 50%-160%	●	●	●	●	●	●	100%
MCR and HSIOC protection	MCR protection mode, trip	●	●	●	●	●	●	Trip
	MCR value, 30In/Icw	●	●	●	●	●	●	30In
	HSIOC protection mode, trip	●	●	●	●	●	●	Trip
	HSIOC value, 30In/Icw	●	●	●	●	●	●	30In
	No tripping time, >20ms	●	●	●	●	●	●	
	Longest tripping time, ≤80ms	●	●	●	●	●	●	
Reduced Instantaneous (RELT)	State setting, Close/Trip	●	●	●	●	●	●	Close
	Select from 2-15In, step 1A	●	●	●	●	●	●	10In
	No tripping time, >20ms	●	●	●	●	●	●	
	Longest tripping time, ≤80ms	●	●	●	●	●	●	

● : Standard; ○ : Optional - : No this function

Mpro Advanced Protection Functions

		Mpro21	Mpro22	Mpro31	Mpro32	Mpro41	Mpro42	Default
Overvoltage and undervoltage protection	State setting, Close/Trip/alarm	-	-	-	-	•	•	Close
	Select from 20V~1500V, step 1V	-	-	-	-	•	•	280V
	Time from 0.1~300s, step 1s	-	-	-	-	•	•	10s
	Return value, 20V~1500V, step 1V	-	-	-	-	•	•	360V
	Return time from 0.1~300s, step 1s	-	-	-	-	•	•	10s
Voltage unbalance protection	State setting, Close/Trip/alarm	-	-	-	-	•	•	Close
	Select from 2%~90%, step 1%	-	-	-	-	•	•	20%
	Time from 0.1~300s, step 1s	-	-	-	-	•	•	10s
	Return value from 2%~90%, step 1%	-	-	-	-	•	•	10%
	Return time from 0.1~300s, step 1s	-	-	-	-	•	•	10s
Under frequency protection	State setting, Close/Trip/alarm	-	-	-	-	•	•	Close
	Select from 40-70Hz, step 0.5Hz	-	-	-	-	•	•	45
	Time from 0.1~300s, step 1s	-	-	-	-	•	•	10s
	Return value from 40-70Hz, step 0.5Hz	-	-	-	-	•	•	49
	Return time from 0.1~300s, step 1s	-	-	-	-	•	•	10s
Over frequency protection	State setting, Close/Trip/alarm	-	-	-	-	•	•	Close
	Select from 40-70Hz, step 0.5Hz	-	-	-	-	•	•	55
	Time from 0.1~300s, step 1s	-	-	-	-	•	•	10s
	Return value from 40-70Hz, step 0.5Hz	-	-	-	-	•	•	51
	Return time from 0.1~300s, step 1s	-	-	-	-	•	•	10s
Reverse power protection	State setting, Close/Trip/alarm	-	-	-	-	•	•	Close
	Select from 50-5000kW, step 10kW	-	-	-	-	•	•	55
	Time from 0.1~300s, step 1s	-	-	-	-	•	•	10s
	Return value from 50-5000kW, step 10kW	-	-	-	-	•	•	51
	Return time from 0.1~300s, step 1s	-	-	-	-	•	•	10s
Phase sequence protection	State setting, Close/Trip/alarm	•	•	•	•	•	•	Close
	Select: a-b-c/a-c-b	•	•	•	•	•	•	a-b-c
Others	Interlock protection	-	-	-	-	•	•	
	Communication ¹⁾	•	•	•	•	•	•	
	Power supply, DC 24V	•	•	•	•	•	•	
	Test module	•	•	•	•	•	•	

• : Standard; ○ : Optional - : No this function

Note: 1) Mpro21/22 control unit, communication module not optional, no communication function; If you need communication function, please select other control units;

Mpro Measurement and maintains

Technical data

A

B

C

		Mpro21	Mpro22	Mpro31	Mpro32	Mpro41	Mpro42	Default
Meter	Current (Ia, Ib, Ic, In, Ig, IgCT)	•	•	•	•	•	•	
	Voltage (Ua, Ub, Uc, Uab, Uac, Ubc)	-	-	-	-	•	•	
	Energy Total Real (kW·h)	-	-	-	-	-	-	
	Active power (L1, L2, L3) (kW)	-	-	-	-	•	•	
	Reactive power (L1, L2, L3) (kVar)	-	-	-	-	•	•	
	Apparent power (L1, L2, L3) (kVA)	-	-	-	-	•	•	
	Factor (L1, L2, L3)	-	-	-	-	•	•	
	Frequency	-	-	-	-	•	•	
	Phase position	-	-	-	-	•	•	
Status	Failure record	•	•	•	•	•	•	
	Alarm record	•	•	•	•	•	•	
	Events record	•	•	•	•	•	•	
	Operate times	•	•	•	•	•	•	
	contact wear	•	•	•	•	•	•	

• : Standard; ◦ : Optional - : No this function

Function menu

On the control unit, pressing the left button can light up the screen, by pressing the 'left button' Pressing the right arrow key can enter the corresponding protection menu, measurement menu, maintenance record menu, system settings menu, and other interfaces to complete all function settings and parameter viewing.

Meter

The meter function can be accessed through the display screen and by pressing the "left" and "right" keys. Press the "confirm" key to enter different electrical parameter display options, and press the "up" and "down" keys to read and observe load current, voltage, apparent, active, reactive power, and other electrical parameters. All current and voltage measurements are based on true RMS.

The control unit of M-PACT circuit breaker provides ammeter function, and Mpro41/42 type provides complete electrical parameter measurement function. The ammeter and electrical parameter measurement functions require power supply to the control unit, which can be achieved through internal power supply, external battery pack, or grid power supply. The complete electrical parameter measurement function requires an external 3-phase voltage transformer and transmitter.

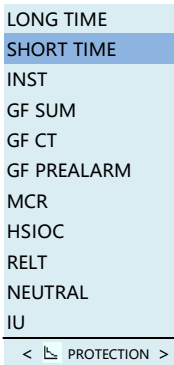
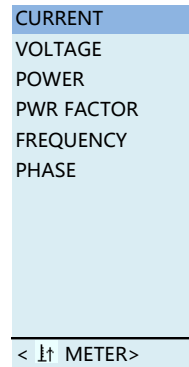

Protection

The Mpro control unit of the circuit breaker can provide Overload long-time (I_r), adjustable overload long delay curve (t_r), adjustable short-circuit short delay protection function (I_{sd} , t_{sd}), and adjustable short-circuit instantaneous protection function (I_i). According to the different models selected by the customer, the control unit also has other advanced protection functions: ground fault, overvoltage and undervoltage, phase sequence, current imbalance, power, frequency, input/output relays, area interlocking, etc. The specific functional details will be described in detail in this chapter.

Status

Select the "Status" function menu through the display screen and press the "Left" and "Right" keys. Press the confirm button to view the corresponding records. You can view data such as fault records, alarm records, event records, and operation times. This function requires an external 24VDC power supply to ensure the continuous operation of the control unit and complete event recording.

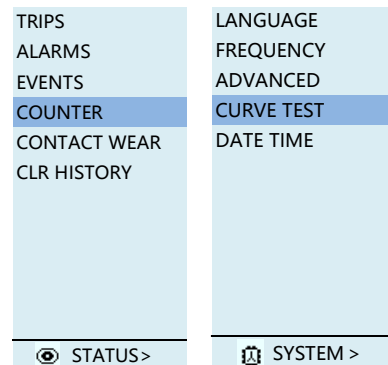

System settings

Select the "System" function through the display screen and press the "Left" and "Right" keys. This menu allows you to set the language type, time, etc. of the control unit.

Overload long-time protection

Overload long-time protection is based on the actual RMS effective current of each phase and neutral line.

Overload long-time protection value setting

The Overload long-time protection is set to:

- Ir : Overload long-time tripping current setting value
- tr : Overload long-time tripping time setting value, at 6Ir

Setting	Unit	Range	Step	Default
Ir	A	(0.2-1) xIn	1A or 0.1xIn	1 xIn
tr	S	0.5-24	0.1	4

Overload long-time protection feature

tr=0.5-24s, step 0.1s

protection feature:

I < 1.05 × Ir: No trip

I > 1.2 × Ir: Tripping

LONG TIME		
SHORT TIME	MODE	TRIP
INST	Ir(*In)	0.2
GF SUM	Ir(A)	640
GF CT	tr(s)	2
GF PREALARM	COOLING	0m
MCR		
HSIOC		
RELT		
NEUTRAL		
IU		
< PROTECTION >		
LONG TIME		

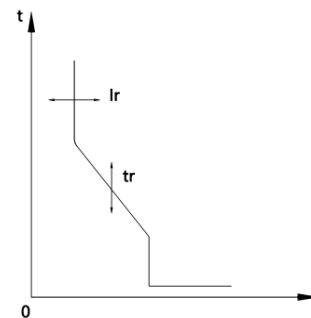

Tr Overload long-time protection time delay is applicable to cold conditions, for phase currents or neutral line currents equal to $6 \times I_r$. When the current is greater than I_{sd} or I_i , the tripping time takes effect according to the short delay and instantaneous protection time. Long delay minimum trip time 500ms.

Tr(@6×Ir)	0.5s	1s	2s	4s	8s	12s	16s	20s	24s
1.5 × Ir	12.5s	25s	50s	100s	200s	300s	400s	500s	600s
6×Ir	0.5s	1s	2s	4s	8s	12s	16s	20s	24s
7.2×Ir	0.34s	0.69s	1.38s	2.76s	5.52s	8.3s	11s	13.8s	16.6s

Short circuit delay protection

Short circuit delay protection is based on the true effective current of the phase.

Setting of short-circuit delay protection value

Short circuit delay protection helps to protect equipment from phase to phase short circuits and phase to ground short circuits, with complete selectivity.

It includes two features: timed and inverse timed, depending on the state of the I²t setting.

Short circuit delay tripping protection accuracy: ± 10%.

The running time of short delay protection depends on the tsd time delay. They are suitable for I²T ON or OFF.

LONG TIME		
SHORT TIME	MODE	TRIP
INST	Ir(A)	3200
GF SUM	Isd(*Ir)	1.5
GF CT	Isd(A)	4800
GF PREALARM	tsd(ms)	100
MCR	I2t	OFF
HSIOC		
RELT		
NEUTRAL		
IU		
< PROTECTION >		
SHORT TIME		

Setting	Unit	Range	Step	Default
Isd	A	(1.5~10) × Ir, OFF	1A	1.5×Ir
Tsd (I ² T ON)	s	0.1~0.4	0.1	-
Tsd (I ² T OFF)	s	0~0.4	0.1	0.1

Short circuit delay protection characteristics

I²T ON tripping curve (I < 10Ir),

$$T = (10/N)^2 \cdot tsd,$$

$$N = I/I_r,$$

$$tsd = 0.1, 0.2, 0.3, 0.4$$

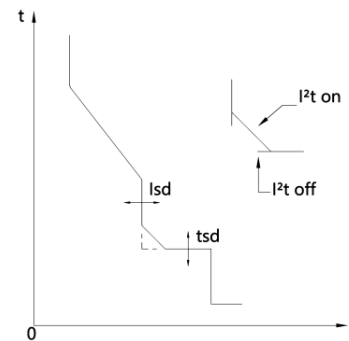

Features	Current multiplier (I/Isd)	Agreed release time
Non action feature	< 0.9	no trip
action feature	> 1.1	tripping
action delay	≥ 1.1	see following table

• I²t ON trip time (I ≥ 10Ir)

Tsd	0.1s	0.2s	0.3s	0.4s
Non action time	> 80ms	> 160ms	> 260ms	> 360ms
Maximum trip time	< 140ms	< 240ms	< 340ms	< 440ms

• I²t OFF trip time

Tsd	0s	0.1s	0.2s	0.3s	0.4s
Non action time	> 20ms	> 80ms	> 160ms	> 260ms	> 360ms
Maximum trip time	< 80ms	< 140ms	< 240ms	< 340ms	< 440ms

Short circuit instantaneous protection

Instantaneous protection can prevent equipment from experiencing short circuits between phase lines, between phase lines and neutral lines, and between phase lines and ground. This protection operates with a time limited characteristic. When the set current is exceeded, the product will trip without any other time delay.

LONG TIME		
SHORT TIME		
INST	MODE	TRIP
GF SUM	li(*In)	2
GF CT	li(A)	6400
GF PREALARM		
MCR		
HSIOC		
RELT		
NEUTRAL		
IU		
< PROTECTION >		
INST		

Short circuit instantaneous protection value setting

Setting	Unit	Range	Step	Default
li	-	off /trip	-	trip
li	A	(2~15) × In	1A	2.0×In

Short circuit instantaneous protection features

$I < 0.9 \times li$: no trip

$I > 1.1 \times li$: tripping

Features	Unit	
Non release time	ms	>20
Maximum release time	ms	≤80

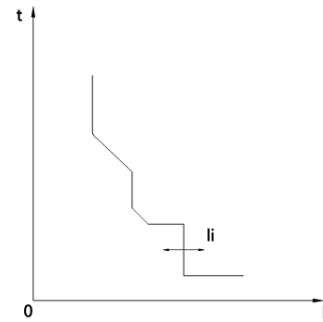

Ground fault protection, GF SUM

Ground fault protection is based on the true effective current of the phase.

Ground fault protection can prevent phase to ground faults and is suitable for TN-S (three-phase five wire system) systems as well as other grounding systems.

The grounding fault current is calculated or measured based on the configuration of the circuit breaker, as shown in the table below.

Calculation method for ground fault protection

Circuit breaker configuration	I _g (Ground fault current)
3P	I _g =I _A +I _B +I _C
4P	I _g =I _A +I _B +I _C +I _N
3P+N(T)	I _g =I _A +I _B +I _C +I _N (ENCT)
3P/4P(W)	I _g =I _W

LONG TIME		
SHORT TIME		
INST	MODE	OFF
GF SUM		
GF CT	I _g (*I _n)	0.2
GF PREALARM	I _g (A)	640
MCR	t _g (ms)	400
HSIOC	I _{2t}	OFF
RELT		
NEUTRAL		
IU		
< PROTECTION		
GF SUM		

Ground fault protection switch and setting

Setting	Unit	Range	Step	Default	accuracy
I _g Enable	-	off / trip	-	off	
I _g	A	I _g =(0.2-1)I _n	1A	0.2 I _n	±10%

Ground fault protection characteristics

The operation time of ground fault protection depends on the T_g time delay. It suitable for I²T ON or OFF.

t _g	0s	0.1s	0.2s	0.3s	0.4s	Default
I ² T ON	-	0.1s	0.2s	0.3s	0.4s	0.1
I ² T OFF	0s	0.1s	0.2s	0.3s	0.4s	0.1

I²t ON trip time (I < I_n)

$$T = (1/N)^2 * t_g$$

$$N = I / I_n$$

$$t_g = 0.1, 0.2, 0.3, 0.4$$

• I²t ON trip time (I ≥ I_n)

t _g	0.1s	0.2s	0.3s	0.4s
Non trip time	> 80ms	> 160ms	> 260ms	> 360ms
Max. trip time	< 140ms	< 240ms	< 340ms	< 440ms

• I²t OFF trip time

t _g	0	0.1s	0.2s	0.3s	0.4s
Non trip time	> 20ms	> 80ms	> 160ms	> 260ms	> 360ms
Max. trip time	< 80ms	< 140ms	< 240ms	< 340ms	< 440ms

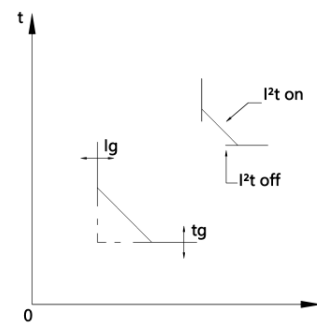

protection features:

I < 0.9 × I_g: no trip

I > 1.1 × I_g: tripping

Ground fault protection, GF CT

Applicable to leakage faults caused by equipment insulation damage or leakage faults caused by human contact with exposed conductive parts, the leakage trip value $I \Delta n$ is directly expressed in amperes and is independent of the rated current of the circuit breaker. The signal acquisition method is zero sequence sampling, which requires an additional rectangular transformer; This type of sampling has high accuracy and sensitivity, and is suitable for protection with small currents. This protection is only applicable to Mpro32/42 control units.

Setting	Unit	Range	Step	Default	Accuracy
Ig Enable	-	Off / Trip	-	off	
Ig Action value	A	$I_g = (0.2-1)I_n$	1A	0.2 I _n	±10%

LONG TIME		
SHORT TIME	MODE	OFF
INST		
GF SUM	Ig(*I _n)	0.2
GF CT	Ig(A)	640
GF PREALARM	tg(ms)	100
MCR	I _{2t}	OFF
HSIOC		
RELT		
NEUTRAL		
IU		
< PROTECTION >		
GF CT		

The operation time of ground fault protection depends on the T_g time delay. It suitable for I²T ON or OFF.

tg	0s	0.1s	0.2s	0.3s	0.4s	Default
I ² T ON	-	0.1s	0.2s	0.3s	0.4s	0.1
I ² T OFF	0s	0.1s	0.2s	0.3s	0.4s	0.1

I²t ON trip time ($I < I_n$); $T = (1/N)^2 \cdot t_g$

$N = I/I_n$; $t_g = 0.1, 0.2, 0.3, 0.4$

• I²t ON trip time ($I \geq I_n$)

tg	0.1s	0.2s	0.3s	0.4s
Non trip time	> 80ms	> 160ms	> 260ms	> 360ms
Max. trip time	< 140ms	< 240ms	< 340ms	< 440ms

• I²t OFF trip time

tg	0	0.1s	0.2s	0.3s	0.4s
Non trip time	> 20ms	> 80ms	> 160ms	> 260ms	> 360ms
Max. trip time	< 80ms	< 140ms	< 240ms	< 340ms	< 440ms

Protection feature:

$I < 0.9 \times I_g$: non trip

$I > 1.1 \times I_g$: tripping

Ground fault pre-alarm

The grounding pre-alarm function and grounding protection function are independent of each other and exist simultaneously, with their own independent setting parameters. The action mode of the alarm function is the same as that of the ground fault protection, using the same sensors, curves, and protection time. Grounding fault pre-alarm is based on the total current of each phase line and neutral line, or external transformers, current grounding circuit current transformers connected to the control unit through modules.

Powered by internal CT without the need for external power supply.

LONG TIME	MODE	GF SUM
SHORT TIME		
INST		
GF SUM	ACT PU	
GF CT		120A
GF PREALARM	ACT TIME	
MCR		1.0s
HSIOC	RETURN PU	
RELT		120A
NEUTRAL	RETURN TIME	
IU		1.0s
< PROTECTION >		
GF PREALARM		

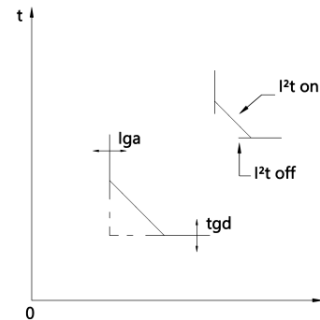

Grounding fault warning setting

Setting	Unit	Range	Step	Setting	Accuracy
Grounding pre alarm mode	-	Off ,GFSUM,GFCT	-	Off	
Grounding and alarm values	A	120-1200A	1A	200A	±10%
Grounding pre alarm time	s	1-10	0.1s	10	> 400ms: ±10%≤400ms: see I²t OFF,Short delay tripping time
Grounding pre alarm return value	A	120-1200A	1A	120A	±10%
Grounding pre alarm return time	S	1-10	0.1s	10	> 400ms: ±10%≤400ms: see I²t OFF,Short delay tripping time

Protection feature:

$I < 0.9 \times I_g$: Un-warning

$I > 1.1 \times I_g$: warning

A

B

C

Neutral line protection (N-phase protection)

In practical applications, the cables and current characteristics used for the neutral phase often differ greatly from those of other three phases, and different protections need to be implemented for the neutral phase according to different application situations. When the neutral line is thin, a semi fixed value method can be used for protection; When the neutral line is the same as others, it can be protected using the method of full set value; When the harmonics in the power grid are relatively heavy, a protection method of 1.6 times the fixed value can be used for protection.

The setting of neutral line protection is only for long delay protection, and other protection settings are the same as those for phase line protection.

LONG TIME		
SHORT TIME		
INST	SWITCH	OFF
GF SUM		
GF CT	N	100%
GF PREALARM		
MCR		
HSIOC		
RELT		
NEUTRAL		
IU		
< PROTECTION		
NEUTRAL		

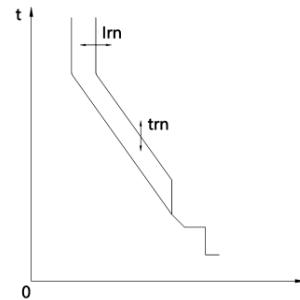

Explanation of M-PACT Neutral Line Protection Corresponding to breaker Types

Item	Breakers	Neutral line protection
1	3PT-3P Breaker	-
2	3P+N-3P Breaker+external neutral line RC	Off, 50%, 100%, 160%
3	4PT- 4P Breaker	Off, 50%, 100%, 160%

Neutral line protection (N-phase protection) setting

Setting	Unit	Range	Default
N-phase protection mode	-	Off / Trip	Trip
N-phase action value	A	50%-160%	100%

Current imbalance protection

Current imbalance protection protects against current imbalance between phase and three-phase, and takes protective actions based on the imbalance rate between the three-phase currents. When the execution mode is alarm, its action principle is the same as grounding protection.

Calculation method for imbalance rate:

$$I_{unbal} = \frac{|E_{max}|}{I_{avg}} \times 100\%$$

Iavg: The average RMS value of the three-phase currents Ia, Ib, Ic:

$$I_{avg} = \frac{I_a + I_b + I_c}{3}$$

E_{max}:The maximum difference between each phase current and Iavg.

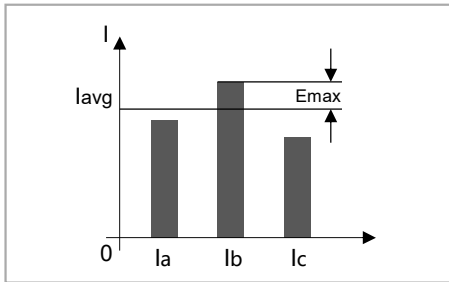

LONG TIME		
SHORT TIME		
INST	MODE	OFF
GF SUM	ACT PU	
GF CT		20%
GF PREALARM	ACT TIME	
MCR		3.0s
HSIOC	RETURN PU	
RELT		20%
NEUTRAL	RETURN TIME	
IU		10.0s
< PROTECTION		
IU		

A

B

C

Current imbalance protection setting

Setting	Unit	Range	Step	Default	Accuracy
Current imbalance mode	-	Off / Trip / Alarm	-	Off	-
Current imbalance action value	%	2%~90%	1%	20%	±10%
Current imbalance time	s	0.1~300s	0.1s	10s	> 400ms: ±10% ≤400ms: 见I²t OFF
Return value of current imbalance	%	2%~90%	1%	2%	±10%
Current imbalance return time	s	0.1~300s	0.1s	10s	> 400ms: ±10% ≤400ms: 见I²t OFF

Undervoltage protection

The control unit measures the true effective value of the main circuit voltage. When the three phase to phase voltages (line voltage) or phase to neutral line voltages (phase voltage) are all less than the set value, that is, when the maximum value of the three voltages is less than the undervoltage protection set value, the undervoltage protection will activate; When the maximum value of the three line voltages is greater than the return value, the alarm action returns.

The control unit needs to be powered by an external 24V power supply.

RELT		
NEUTRAL		
IU	MODE	OFF
LOAD MONIT	ACT PU LN	
UV		20V
OV	ACT TIME	
VU		10.0s
UF	RETURN PU LN	
OF		20V
RP	RETURN TIME	
PS		10.0s
< PROTECTIO		
UV		

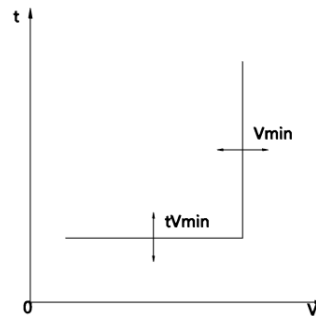

Undervoltage protection setting

Setting	Unit	Range	Step	Default	Accuracy
Undervoltage protection mode	-	Off/ Trip/ Alarm	-	Off	-
Undervoltage protection action value	V	20V ~ 1500V	1V	280V	±5%
Undervoltage protection time	s	0.1~300s	0.1s	10s	> 400ms: ±5% ≤400ms: see I ² t OFF
Under voltage protection return value	%	20V ~ 1500V	1V	360V	±5%
Undervoltage protection return time	s	0.1~300s	0.1s	10s	> 400ms: ±5% ≤400ms: see I ² t OFF

A

B

C

A

B

C

Overvoltage protection

The control unit measures the true effective value of the main circuit voltage. When all three phase to phase voltages (line voltage) or phase to neutral line voltages (phase voltage) are greater than the set value, that is, when the minimum value of the three voltages is greater than the overvoltage protection set value, the overvoltage protection will activate; When the minimum value of the three voltages is less than the return value, the alarm action returns. When the minimum line voltage is greater than the action threshold, an alarm or trip delay is triggered. When the action delay time is reached, an alarm or trip

RELT		
NEUTRAL	MODE	OFF
IU	ACT PU LN	
LOAD MONITC		400V
UV	ACT TIME	
OV		10.0s
VU	RETURN PU LN	
UF		220V
OF	RETURN TIME	
RP		10.0s
PS		
< PROTECTION >		
OV		

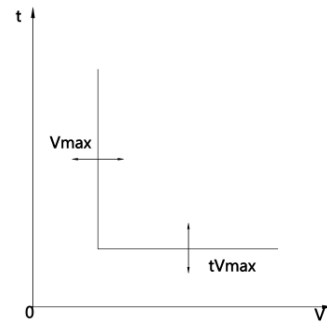

Overvoltage protection setting

Setting	Unit	Range	Step	Default	Accuracy
Overvoltage protection mode	-	Off / Trip/Alarm	-	Off	-
Overvoltage protection action value	V	20V ~ 1500V	1V	460V	±10%
Overvoltage protection time	s	0.1~300s	0.1s	10s	> 400ms: ±10%
Overvoltage protection return value	%	20V ~ 1500V	1V	440V	±10%
Overvoltage protection return time	s	0.1~300s	0.1s	10s	> 400ms: ±10%

Voltage imbalance protection

Voltage imbalance protection operates based on the imbalance rate between three line voltages. Its operating principle is the same as overvoltage protection.

Calculation method for imbalance rate:

$$U_{unbal} = \frac{|E_{max}|}{U_{avg}} \times 100\%$$

U_{avg} : The average RMS value of three-phase line voltage

$$U_{avg} = \frac{U_{ab} + U_{ac} + U_{bc}}{3}$$

E_{max} : The maximum difference between each line voltage and the average value.

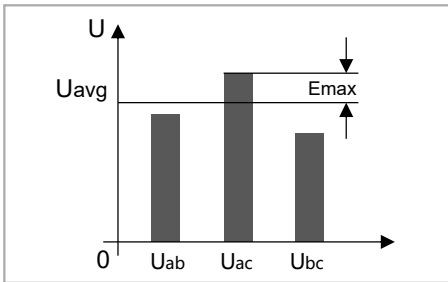

RELT		
NEUTRAL		
IU	MODE	OFF
LOAD MONITOR	ACT PU	
UV		20%
OV	ACT TIME	
VU		10.0s
UF	RETURN PU	
OF		10%
RP	RETURN TIME	
PS		10.0s
< PROTECTION >		
VU		

Voltage imbalance protection setting

Setting	Unit	Range	Step	Default	Accuracy
Voltage imbalance protection mode	-	Off / Trip / Alarm	-	Off	-
Voltage imbalance protection action value	%	2%~90%	1%	20%	±10%
Voltage imbalance protection time	s	0.1~300s	0.1s	10s	> 400ms: ±10% ≤400ms: see I ² t OFF
Voltage imbalance protection return value	%	2%~90%	1%	10%	±10%
Voltage imbalance protection return time	s	0.1~300s	0.1s	10s	> 400ms: ±10% ≤400ms: see I ² t OFF

A

B

C

Underfrequency protection

The control unit detects the frequency of the system voltage and can provide protection for frequencies that are too high or too low. The operating principles and characteristics of over frequency and under frequency protection are the same as those of over voltage and under voltage protection.

Powered by an external 24V power supply.

RELT		
NEUTRAL		
IU	MODE	OFF
LOAD MONITO	ACT PU	
UV		45.0HZ
OV	ACT TIME	
VU		10.0s
UF	RETURN PU	
OF		50.0HZ
RP	RETURN TIME	
PS		10.0s
< PROTECTION >		
UF		

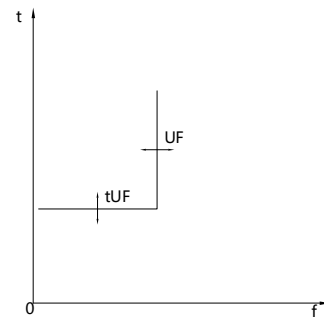

Underfrequency protection setting

Setting	Unit	Range	Step	Default	Accuracy
Underfrequency protection mode	-	Off / Trip / Alarm	-	Off	-
Underfrequency protection action value	Hz	40 ~ 70	0.1Hz	45	±10%
Underfrequency protection time	s	0.1~300s	0.1s	10s	> 400ms: ±10% ≤400ms: see I ² t OFF
Underfrequency protection return value	Hz	40 ~ 70	0.1 Hz	49	±10%
Underfrequency protection return time	s	0.1~300s	0.1s	10s	> 400ms: ±10% ≤400ms: see I ² t OFF

Overfrequency protection

The control unit detects the frequency of the system voltage and can provide protection for frequencies that are too high or too low. The operating principles and characteristics of overlocking and overlocking protection are the same as those of overvoltage and undervoltage protection.

Powered by an external 24V power supply.

RELT		
NEUTRAL		
IU	MODE	OFF
LOAD MONITC	ACT PU	
UV		55.0HZ
OV	ACT TIME	
VU		10.0s
UF	RETURN PU	
OF		50.0HZ
RP	RETURN TIME	
PS		10.0s
< PROTECTION >		
过频		

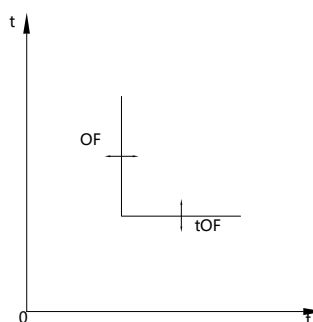

Overfrequency protection setting

Setting	Unit	Range	Step	Default	Accuracy
Overfrequency protection mode	-	Off / Trip/Alarm	-	Off	-
Overfrequency protection action value	Hz	40 ~ 70	0.1 Hz	55	±10%
Overfrequency protection time	s	0.1~300s	0.1s	10s	> 400ms: ±10% ≤400ms: see I²t OFF
Overfrequency protection return value	Hz	40 ~ 70	0.1 Hz	51	±10%
Overfrequency protection return time	s	0.1~300s	0.1s	10s	> 400ms: ±10% ≤400ms: see I²t OFF

Power reversal protection

Power reversal protection, also known as reverse active power protection, takes the sum of three-phase active power. When the direction of power flow is opposite to the user set power direction and greater than the set value, the protection is activated. The power direction and power input direction should be set in the "Measurement Meter Settings" menu and must be consistent with the actual application situation. Its operating principle is the same as overvoltage protection.

Powered by an external 24V power supply.

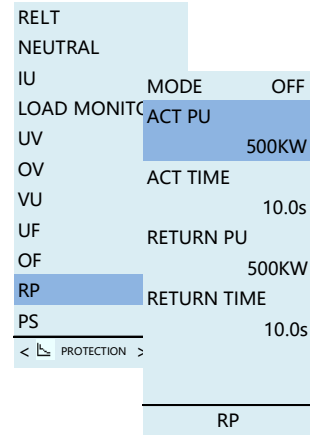

A

Power reversal protection setting

Setting	Unit	Range	Step	Default	Accuracy
Power reversal protection mode	-	Off / Trip / Alarm	-	Off	-
Power reversal action value	kW	50 ~ 5000	10	55	±10%
Power reversal protection time	s	1 ~ 300s	0.1s	10s	> 400ms: ±10% ≤400ms: see I ² t OFF
Power reversal protection return value	kW	50 ~ 5000	10	51	±10%
Power reversal protection return time	s	1 ~ 300s	0.1s	10s	> 400ms: ±10% ≤400ms: see I ² t OFF

B

C

Phase sequence protection

The phase sequence detection is taken from the main circuit voltage. When the phase sequence is detected to be in the same direction as the starting value setting, the protection action is activated, and the protection characteristic is instantaneous. When one or more phase voltages are not present, this function automatically exits.

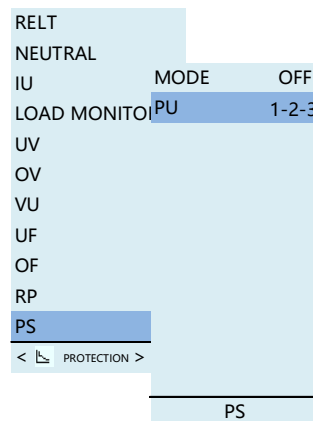

Phase sequence protection setting

Setting	Unit	Range	Step	Default	Accuracy
Phase sequence protection mode	-	Off / Trip / Alarm	-	Off	-
Phase sequence protection action value	-	1-2-3/1-3-2	-	1-2-3	-

Measurement of electrical parameters

Ammeter

The Mpro control unit provides current measurement function, which can measure the current of each phase, as well as the grounding current, average current, current imbalance, and minimum imbalance.

CURRENT	
VOLTAGE	
POWER	RMS
PWR FACTOR	I1: 0.00A
FREQUENCY	I2: 0.00A IgCT: 0.00A
PHASE	I3: 0.00A I1: 0.00A
	Ig: 0.00A I2: 0.00A
	IgCT: 0.00/I3: 0.00A
	MAX UNBALANCE
	I1: 0.00A I1: 0%
	I2: 0.00A I2: 0%
	I3: 0.00A I3: 0%
< ⏪ METER >	Ig: 0.00A I1: 100%
	CURRE I2: 100%
	I3: 202%
	CURRENT

Standard on

Mpro21/22

Mpro31/32

Mpro41/42

Measurement of electrical parameters

The Mpro41/42 control unit provides comprehensive electrical parameter measurement functions, allowing customers to browse real-time data of multiple electrical parameters. The menu on the right lists most of the parameter measurement functions. After entering the "Measurement" menu, users can select and browse the corresponding measurement functions.

		RMS
CURRENT	U12: 0V	
VOLTAGE	U23: 0V	
POWER	U31: 0V	
PWR FACTOR	U1N: 0V	P(KW)
FREQUENCY	U2N: 0V	P1: 0
PHASE	U3N: 0V	P2: 0
	MAX P3: 0	PF
	U12: 0V	Ptot : 0 PF1: 0.0
	U23: 0V	Q(KV)/PF2: 0.0
	U31: 0V	Q1: 0 PF3: 0.0
< ⏪ METER >	VOLTA	Q2: 0 PF : 0.0
	Q3: 0	
	Qtot : 0	
	S(KV,	
	POWER	
		PWR FACTOR

It can measure the maximum, minimum, average, and voltage imbalance of the displayed voltage. Users can choose to view line voltage or phase voltage type according to their needs.

The power measurement function for supply and demand includes effective power P (kW), apparent power Q (KVA), and reactive power S (KVAR).

The Mpro control unit provides advanced measurement functions such as power factor, frequency, phase, etc.

Standard on

Mpro41/42

Voltage measurement and external additional power supply

It is necessary to measure the voltage of the three-phase and neutral lines using the above-mentioned comprehensive electrical parameter measurement function, and feedback this data to the control unit. The Mpro41/42 control unit provides standard voltage measurement and transmission modules for safe and reliable measurement of voltage parameters by the control unit.

Accessory

Mpro41/42

External additional power supply and reset settings

External additional power supply

The application of advanced functions of the control unit requires an external 24V DC power supply for continuous power supply. The auxiliary power supply unit module can convert the corresponding grid voltage to 24V DC, and this module can also set parameters for the control unit when the load current is low (<20%).

In addition, the testing module can also be used to temporarily supply power to the control unit.

The test module is equipped with a built-in 24V DC battery pack module.



Reset settings

Usually, circuit breakers trip due to circuit faults. Users need to carefully check the specific cause of the fault in the lower level circuit, confirm the cause of the fault and eliminate it before allowing the circuit breaker to be reset and reconnected. The Mpro electronic control unit provides a comprehensive fault trip recording function to help customers analyze the cause, level, size, and location of faults, and take corresponding measures.



In order to track the occurrence of faults, the control unit provides a trip reset function, usually manual reset. But customers can also set the trip reset to manual or automatic reset through the selection knob on the panel. If remote reset of the circuit breaker is required, the selection button on the panel can be set to manual reset, and a remote reset coil can be equipped to achieve the function of tripping and resetting the circuit breaker.



A

Communication function

Communication function

The optional communication function of the control unit has full duplex Modbus RTU communication function. The communication function requires an external 24V DC power supply, and for Modbus, a power capacity of no less than 90mA is required.

The control unit complies with the Modbus communication protocol and a 2-wire RS485 interface, and can set baud rates of 4800, 9600, and 19200.

The control unit with communication function can simultaneously set parameters through panel or communication, including overcurrent protection setting and protection relay setting.



B

NFC function

All Mpro control units are equipped with NFC near-field communication function, using short-range wireless communication method, integrating RFID and interconnection technology, supporting the use of compatible devices to quickly and easily identify and exchange data with M-PACT air circuit breakers at close range.

C



Testing module

The testing module is used to verify whether the coordination between the circuit breaker and the control unit is good. This module is equipped with a 24V DC battery pack, which can be used to supply power to the control unit when there is no load current in the distribution network. There is a test port on the control unit panel for connecting with the test module.

The circuit breaker management software toolkit allows users to monitor, set, and even test the trip curve through a laptop.



Protection relay: relay input/output

Relay input DI

Provide two relay input functions. Each relay input can choose OFF/TRIP/RELT (one of three options), configured as follows:

DI	Function	Description
Setting option	OFF	OFF
	TRIP	After inputting the signal, the circuit breaker outputs a trip pulse to the magnetic flux coil, causing the circuit breaker to trip
	RELT	After inputting the signal, enable the RELT setting value. (RELT must be set to remote)

Relay output DO

Provide 2 relay output functions. The first group has been automatically assigned to circuit breaker closing, and the second group has been automatically assigned to circuit breaker opening. Each relay output can choose EVENT/ALARM/TRIP (one out of three), and there are multiple options in the sub menu for each function, as shown in the table below

DO	Function	Description
Setting option	EVENT	Action event Lower level menu: NONE (no output), REMOTE-OFF (remote opening), REMOTE-ON (remote closing), RELT-ON (dual short circuit protection)
	ALARM	Send an alarm command, and the circuit breaker will execute the alarm when receiving it Submenus: ALL (All), SELF-TEST (Self check Test), CONT (Electrical Contact Life), PS (Phase Sequence), OF (Overfrequency Alarm), UF (Underfrequency Alarm), RP (Power Reverssal Alarm), VU (Voltage Imbalance Alarm), OV (Overvoltage Alarm), UV (Undervoltage Alarm), IU (Current Imbalance Alarm), N-ST (N-Phase Short Circuit Short Delay Alarm), N-LT (N-Phase Overload Long Time Alarm), GFCT (Ground Leakage Alarm), GFSUM (Ground Fault Alarm), GA (Ground Alarm), LT (Overload Long Time Alarm), NONE (No Output)
	TRIP	Send output command, circuit breaker receives trip pulse, magnetic flux trips, circuit breaker trips ALL (All), PS (Phase Sequence), OF (Overfrequency Protection), UF (Underfrequency Protection), RP (Reverse Power Protection), VU (Voltage Imbalance Protection), OV (Overvoltage Protection), UV (Undervoltage Protection), IU (Current Imbalance Protection), N-I (N-Phase Short Circuit Transient Protection), N-ST (N-Phase Short Circuit Short Delay Protection), N-LT (N-Phase Overload Long Time Protection), RELT (Double Short Circuit Protection), HSIOC (Restricted Short Circuit Transient Protection), MCR (Closed Short Circuit Protection), GF CT (Ground Leakage Protection), GF SUM (Ground Fault Protection), I (Short Circuit Transient Protection), ST (Short circuit short delay protection), LT (Overload long Time protection), NONE (No output)



Note: Mpro21/22 control unit, no relay input/output configuration.

Accessories

A wide range of optional accessories have been developed that are compatible with all M-PACT air circuit breakers, regardless of nominal rating or frame size. Each one incorporates 'easy-fit' design features for quick installation, either in the factory or by the user on site.

Motorised spring charging unit



The unique motor/gearbox unit is specially designed to operate with the full range of M-PACT breakers. It is easily fitted with just two bolts. In the event of circuit breaker closure, this unit will automatically recharge the spring in readiness for instant reclosure should the need arise. High speed recharging ensures that the springs are fully charged within approximately three seconds following a release. As an optional feature, a "springs charged" contact is available for the motor unit.

Circuit breaker closing coil



The closing coil is an easy-to-fit, clip-on unit, with simple plug-in connectors. This permits either local or remote release of the spring charged closing mechanism by electrical operation. An additional anti-pumping safety feature also ensures that the electrical closing signal must be released before further closure is attempted, and a cut-off is instigated should a closing signal be maintained. Because each coil operates within a wide voltage range, the number of individually rated coils required is drastically reduced.

Shunt trip



Energisation, locally or remote, will instantaneously activate the circuit breaker mechanism, ensuring rapid disconnection of the main contacts. In addition, a series connected auxiliary switch ensures automatic isolation whenever the circuit breaker is open. Shunt trip releases also have a wide operational voltage range, and they include the same easy-fit, clip-on/plug-in connectors as the closing coil above.

Undervoltage release



Instantaneously releases the circuit breaker trip mechanism should the supply voltage dip below the pre-set value. Simple to install, these devices have the same easy-fit features as previously described. Note: This is a 'no-volt/ no-close device. The circuit breaker cannot be closed (manually or electrically) unless the undervoltage release coil is energised. Time delay undervoltage release Similar to the above, but this electronic device prevents nuisance tripping of the circuit breaker if circuit interruption is not desirable when supply voltage drop is only transient. Fixed time delay 3 sec ±1sec.(Frame 3 Configure TDM delay module, 0-3s adjustable)

Auxiliary trip combination

The M-PACT circuit breaker can be equipped with the following auxiliary trips or releases 1 x Shunt trip + 1 x Closing coil + 1 x Undervoltage release or 1 time delay Undervoltage release.

Auxiliary switches

The M-PACT circuit breaker is equipped with 5 NO and 3 NC auxiliary switches as standard for Frame 1 and Frame 2.

Frame 3 equipped with 8 NO and 8 NC auxiliary switches.

Mechanical operation counter



Easily fitted, this useful accessory may be specified for use with either manual or motor charged M-PACT circuit breakers. It is clearly visible through the front panel, and the counter provides an accurate record of the cumulative number of complete breaker closing operations.

Key interlock facility

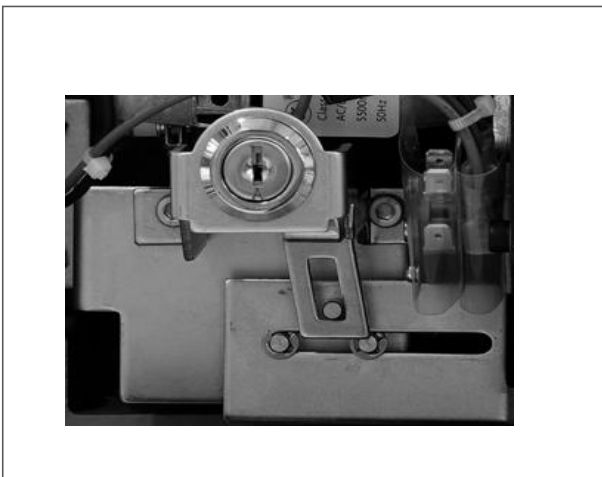

Ready-to-fit interlocking device: Ronis, for installation between separate circuit breakers, available in kit form.

This valuable safeguard ensures that a circuit breaker cannot be closed unless the dedicated key has been inserted and secured within the lock.

Cassette main terminal adaptors



Combinations of rear and front access connections possible for entire range. Tested and approved from 50 to 80kA.

To simplify main busbar or cable termination, M-PACT provides a full range for rear and/or front access connection. Bolt-on adaptor kits can be fitted easily to suit either horizontal or vertical connections.

A

B

C

Carriage position switch

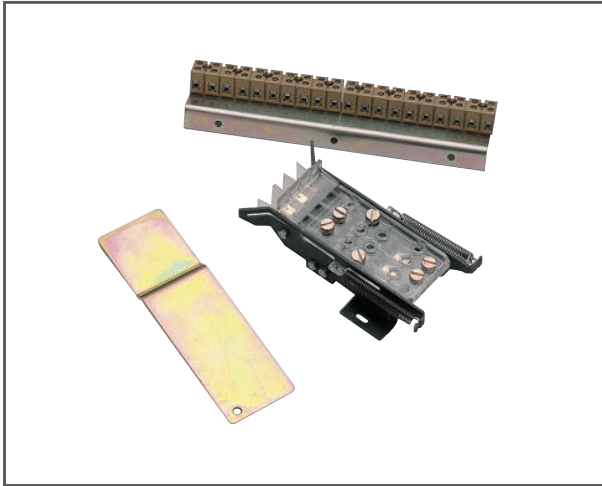

Available as an optional device for mounting within the base of the cassette, this switch provides six single pole changeover contacts for local or remote electrical indication of the circuit breaker status: Connected, Test and Disconnected.

The Disconnected position is indicated only when minimum isolating distances between contacts on both the main and auxiliary circuits have been achieved.

This option is in addition to the mechanical indicators which are fitted as standard.

When installed, the carriage switch is IP2X protected and includes wiring to a terminal block located on the left-hand side of the cassette.

Note: The carriage position switch is an option only suitable for withdrawable circuit breakers.

Cluster contacts

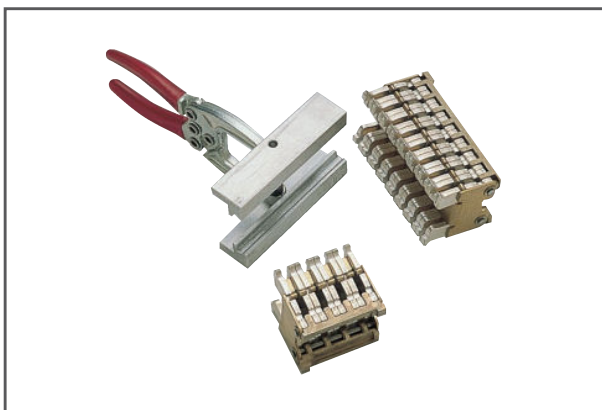

These are the main isolating contacts which are fitted to the rear terminals on the moving portion of the withdrawable unit.

As part of standard inspection and maintenance procedures, cluster contacts have been designed to be easily and quickly.

2/3 way cable mechanical interlocks



Available for fixed and withdrawable circuit breakers. These units enable the direct interlocking of M-PACT circuit breakers, either mounted side-by-side or stacked. The interlocking mechanisms are connected by a specially designed cable in '1 from 3' OR '2 from 3' configuration, and any mix of current ratings / pole configurations can be accommodated.

Standard cable lengths available: 1.6, 2.0, 3.0 metres. (Please contact our technical customer service department if longer length is required.)

Interlocks

Mechanical interlocks can be fitted to the following electrical systems and can link 2 or 3 circuit breakers of any rating or number of poles, fixed or withdrawable.

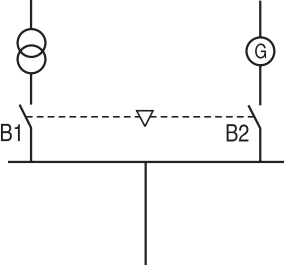
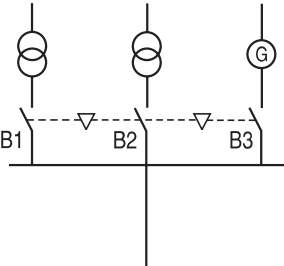
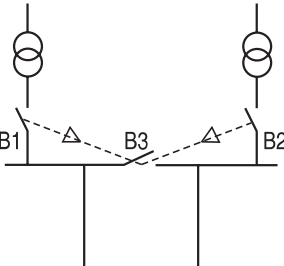
Typical circuit	Interlock configuration	Possible combinations																								
	<p style="text-align: center;">Type A</p> <p>Interlocking between 2 circuit breakers</p> <p>B1 normal power supply B2 generator (emergency) supply</p>	<table border="1" style="margin-left: auto; margin-right: auto;"> <thead> <tr> <th>B1</th> <th>B2</th> </tr> </thead> <tbody> <tr> <td>0</td> <td>0</td> </tr> <tr> <td>1</td> <td>0</td> </tr> <tr> <td>0</td> <td>1</td> </tr> </tbody> </table> <p style="text-align: center;">Circuit breaker B1 can only close if B2 is open Circuit breaker B2 can only close if B1 is open</p>	B1	B2	0	0	1	0	0	1																
B1	B2																									
0	0																									
1	0																									
0	1																									
	<p style="text-align: center;">Type B</p> <p>Interlocking between 3 circuit breakers</p> <p>3 power supplies (generator or transformers) feeding the same busbar but parallel operation is prevented.</p>	<table border="1" style="margin-left: auto; margin-right: auto;"> <thead> <tr> <th>B1</th> <th>B2</th> <th>B3</th> </tr> </thead> <tbody> <tr> <td>0</td> <td>0</td> <td>0</td> </tr> <tr> <td>1</td> <td>0</td> <td>0</td> </tr> <tr> <td>0</td> <td>1</td> <td>0</td> </tr> <tr> <td>0</td> <td>0</td> <td>1</td> </tr> </tbody> </table> <p style="text-align: center;">Only 1 from 3 breakers can be closed</p>	B1	B2	B3	0	0	0	1	0	0	0	1	0	0	0	1									
B1	B2	B3																								
0	0	0																								
1	0	0																								
0	1	0																								
0	0	1																								
	<p style="text-align: center;">Type C</p> <p>Interlocking between 3 circuit breakers</p> <p>2 bus sections can be powered by a single transformer (bus coupler closed) or by both transformers (bus coupler open).</p>	<table border="1" style="margin-left: auto; margin-right: auto;"> <thead> <tr> <th>B1</th> <th>B2</th> <th>B3</th> </tr> </thead> <tbody> <tr> <td>0</td> <td>0</td> <td>0</td> </tr> <tr> <td>1</td> <td>0</td> <td>0</td> </tr> <tr> <td>0</td> <td>1</td> <td>0</td> </tr> <tr> <td>0</td> <td>0</td> <td>1</td> </tr> <tr> <td>1</td> <td>0</td> <td>1</td> </tr> <tr> <td>0</td> <td>1</td> <td>1</td> </tr> <tr> <td>1</td> <td>1</td> <td>0</td> </tr> </tbody> </table> <p style="text-align: center;">Any 2 from 3 circuit breakers can be closed Any 1 from 3 circuit breakers can be closed</p>	B1	B2	B3	0	0	0	1	0	0	0	1	0	0	0	1	1	0	1	0	1	1	1	1	0
B1	B2	B3																								
0	0	0																								
1	0	0																								
0	1	0																								
0	0	1																								
1	0	1																								
0	1	1																								
1	1	0																								

A

B

C

Circuit breaker insertion interlock

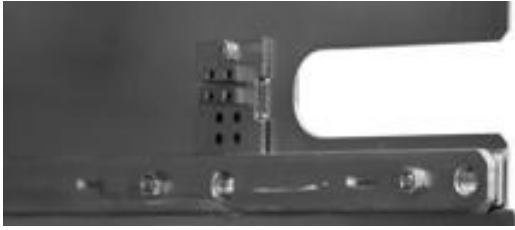

By incorporating this optional security interlock device into a system, it prevents the inadvertent insertion of an incorrectly rated withdrawable circuit breaker into a cassette.

Cassette interlock



Available for withdrawable circuit breakers only, this sophisticated interlock system secures the circuit breaker in the disconnected position by means of a Ronis key. When the key is removed, the safety shutters are automatically locked in position, thus preventing access to the contacts and also ensuring that the racking mechanism is not operable. For lock and key details refer to key interlock facility section.

Sealed door panel escutcheon



An optional IP54 complete front door panel is available should a higher degree of protection be necessary.

Circuit breaker handling truck

Specifically designed for use with the M-PACT Plus range, this dedicated handling truck is a useful accessory when faced with the task of inserting or removing the circuit breaker from its panel, or when transporting the unit should it be outside its cassette. Installers will also find it particularly valuable for top-tier mounted circuit breakers.



Portable Test Unit



Specially designed for reliable testing of the MCR and HSISC protection systems on each phase, by means of tertiary injection. The test unit incorporates a set of rechargeable batteries and includes a charger unit as standard.

Auxiliary Power Unit



Available to be fitted within the circuit breaker cubicle, an APU ensures that MPRO receives independent and continuous power at all times. The APU accepts any input supply voltage within 380VAC, 110V, 220V AC/DC. Maximum input current is 0.5 A. 1m length cable (twisted pair) should be used to connect auxiliary supply and MPRO protection relay.

Accessories Performance Data					
Device	Operating Voltage(V)		Operating range	Rating , (Amps resistive)	
	AC	DC		Frame 1, Frame 2	Frame 3
Auxiliary and Carriage switch	250		-	10A	AC 21-10A AC 23-5A
		125	-	5A	DC21-10A
		250		0.25A	DC21.0.25A
Motor operator	220-250	220-250	0.85-1.1 rated voltage	AC-50VA DC-50W	AC-560VA DC-480W
	110-130	110-130			
	380-440	48, 60 24-30			
Closing coil	220-250	220-250	0.85-1.1 rated voltage	AC-300VA DC-250W	350VA 350W pull-in 60VA 50W hold
	110-130	110-130			
	380-440	48 24-30			
Shunt trip	220-250	220-250	0.7-1.1 rated voltage	AC-300VA DC-250W	350VA/350W pull-in 60VA/50W hold
	110-130	110-130			
	380-440	48 24-30			
Undervoltage Release	380-440	110-130	" pull-in " 0.85-1.1×rated voltage "release" 0.7-0.35×rated voltage	300VA, after 0.4s down to 20VA	350VA/350W pull-in 60VA/50W hold
	220-250	48			
	110-130				
Undervoltage time delay	380-440	110-130	F1,F2: 3± 1s delay F3: 0-3s delay	350VA opening 20VA closing	350VA pull-in 60VA hold
	220-250	48			
	110-130				
Auxiliary power unit	110, 220, 380	110, 220	-	-	-

Air circuit breaker 400A-6400A

A

Technical data

B

Order codes

C

Wiring diagrams
Dimensional drawings

- B.2 Specify on the order
- B.4 Quickly select circuit breaker model
- B.5 M-PACT Air circuit breaker - type A 50kA
- B.7 M-PACT Air circuit breaker - type D 70kA
- B.9 M-PACT Air circuit breaker - type H₁,H₂, 80kA
- B.11 Accessories

M-PACT Air circuit breaker 5000-6400A

Order codes

1.PO No.:	2.Delivery date:	3.Switchgear manufacturer:		
4.Project name:	5.Customer name:	6.Industry:	7.Quantity:	Pcs
Specify on the Order				
Code	M-PACT	<input type="checkbox"/> <input type="checkbox"/> <input type="checkbox"/> <input type="checkbox"/> <input type="checkbox"/> <input type="checkbox"/> <input type="checkbox"/> <input type="checkbox"/> <input type="checkbox"/> <input type="checkbox"/> <input type="checkbox"/> <input type="checkbox"/> <input type="checkbox"/> <input type="checkbox"/> <input type="checkbox"/> <input type="checkbox"/> <input type="checkbox"/> <input type="checkbox"/> <input type="checkbox"/> <input type="checkbox"/>	Type	<input type="checkbox"/> Withdrawable <input type="checkbox"/> Fixed
Voltage (Ue)	<input type="checkbox"/> AC415V <input type="checkbox"/> AC690V			
Frame 3, 5000-6400A	<input type="checkbox"/> Type M, 100kA, AC415V <input type="checkbox"/> Type L, 150kA, AC415V			
Rating	<input type="checkbox"/> 5000A <input type="checkbox"/> 6400A			
Number of poles	<input type="checkbox"/> 3P <input type="checkbox"/> 4P Right Neutral(Standard) <input type="checkbox"/> 4P Left Neutral			
Busbar of withdrawable	<input type="checkbox"/> T-shape rear horizontal ⁽¹⁾ <input type="checkbox"/> T-shape rear vertical			
Busbar of Fixed	<input type="checkbox"/> Rear Horizontal (standard) <input type="checkbox"/> vertical terminal adapter for upper <input type="checkbox"/> vertical terminal adapter for bottom			
Control unit	<input type="checkbox"/> MproA13 <input type="checkbox"/> MproA16 <input type="checkbox"/> MproP13H <input type="checkbox"/> MproP16H			
Optional grounding protection	<input type="checkbox"/> 3P, external neutral wire RC (UEF) <input type="checkbox"/> External grounding CT (SEF)			
Extended functions	<input type="checkbox"/> Modbus communication module <input type="checkbox"/> DI/DO module			
Auxiliary Power Unit	<input type="checkbox"/> Wide voltage module, AC 100-400V , DC 110/220V			
Control Voltage				
Motor operator	<input type="checkbox"/> DC24V <input type="checkbox"/> AC/DC110-130V <input type="checkbox"/> AC/DC220-240V <input type="checkbox"/> AC250-277V <input type="checkbox"/> AC380-415V			
Closing Coil	<input type="checkbox"/> DC24V <input type="checkbox"/> AC/DC110-130V <input type="checkbox"/> AC/DC220-240V <input type="checkbox"/> AC250-277V <input type="checkbox"/> AC380-415V			
Shunt Trip	<input type="checkbox"/> DC24V <input type="checkbox"/> AC/DC110-130V <input type="checkbox"/> AC/DC220-240V <input type="checkbox"/> AC250-277V <input type="checkbox"/> AC380-415V			
Undervoltage release	<input type="checkbox"/> DC24V <input type="checkbox"/> AC/DC110-130V <input type="checkbox"/> AC/DC220-240V <input type="checkbox"/> AC250-277V <input type="checkbox"/> AC380-415V			
Undervoltage delay module	<input type="checkbox"/> DC24V <input type="checkbox"/> AC/DC110-130V <input type="checkbox"/> AC/DC220-240V <input type="checkbox"/> AC250-277V <input type="checkbox"/> AC380-415V			
Auxiliary contact	<input type="checkbox"/> power type 4NO+4NC <input type="checkbox"/> power type 8NO+8NC <input type="checkbox"/> power type 4NO+4NC, signal type 4NO+4NC			
Trip alarm contact	<input type="checkbox"/> power type 1NO+1NC <input type="checkbox"/> signal type 1NO+1NC <input type="checkbox"/> Mechanical operation counter <input type="checkbox"/> breaker RTC indicator 1NO			
Position Indication Contacts Cassette	<input type="checkbox"/> power type 1NO+1NC <input type="checkbox"/> power type 2NO+2NC <input type="checkbox"/> power type 1NO+1NC, signal type 1NO+1NC			
Lock for off position	<input type="checkbox"/> Lock A <input type="checkbox"/> Lock B <input type="checkbox"/> Lock C <input type="checkbox"/> Lock D <input type="checkbox"/> Lock E			
Cable Interlock	<input type="checkbox"/> Type A <input type="checkbox"/> Type B <input type="checkbox"/> Type C <input type="checkbox"/> Type D			
Cable Length	<input type="checkbox"/> 1.5m <input type="checkbox"/> 2m <input type="checkbox"/> 3m <input type="checkbox"/> Padlocking device for Pushbuttons <input type="checkbox"/> Phase separators			
If there are any other special requirements, please indicate them here:				

Customer signature:

Standard configuration of circuit breaker: energy storage motor (with signal output), closing coil, opening coil, 4NO+4NC power type alarm contact, external auxiliary power supply for control unit, standard door frame, drawer type circuit breaker bracket, rear T-shaped terminal block (drawer type)

Note 1: When frame 3 @ 6400A is used for horizontal wiring, it is recommended to increase the cross-sectional area of the connecting copper bar, strengthen heat dissipation measures, or reduce the capacity for use

Quickly select circuit breaker

Frame 1, Frame 2

MP	D			3		1		W		25		Mpro21	
Series	Breaking capacity			Poles		Frame		Installation		Current		Mpro Control unit	
M-PACT Air circuit breaker	A	50kA	Frame 1, 2	3	3P	1	Frame 1	W	Withdrawable	04	400A	Mpro21	Mpro21
	D	70kA	Frame 1, 2	4	4P	2	Frame 2	F	Fixed	06	630A	Mpro22	Mpro22
	H1	80kA	Frame 2							08	800A	Mpro31	Mpro31
	H2	80kA	Frame 2							10	1000A	Mpro32	Mpro32
										12	1250A	Mpro41	Mpro41
										16	1600A	Mpro42	Mpro42
										20	2000A	Non	Non
										25	2500A		
										32	3200A		
										40	4000A		

Note: Frame 1, Ue= 690V, Icu=Ics=Icw=65kA, the breaking code is D2.

Frame 3

MP	M			3		3		W		50		MproA13	
Series	Breaking capacity			Poles		Frame		Installation		Current		Mpro Control unit	
M-PACT Air circuit breaker	M	100kA	Frame 3	3	3P	3	Frame3	W	Withdrawable	50	5000A	MproA13	MproA13
	L	150kA	Frame 3	4	4P			F	Fixed	64	6400A	MproA16	MproA16
												MproP13H	MproP13H
												MproP16H	MproP16H
												Non	Non

Control Unit Functions Overview

Mpro21	LSI protection, current measurement, no DI/DO, communication module not optional
Mpro22	LSIG protection, current measurement, no DI/DO, communication module not optional
Mpro31, MproA13	LSI protection, current measurement, with DI/DO, optional communication module
Mpro32, MproA16	LSIG protection, current measurement, with DI/DO, optional communication module
Mpro41, MproP13H	LSI protection, full electrical parameter measurement, with DI/DO, optional communication module
Mpro42, MproP16H	LSIG protection, full electric parameter measurement, with DI/DO, optional communication module
Blank	Non-protection

Note: The following components are standard configurations for circuit breakers:

1. 24V DC auxiliary power supply
2. IP30 flange door
3. T-shaped or L-shaped terminal of withdrawable circuit breaker
4. Auxiliary contacts of 4NO+4NC or 5NO+3NC
5. The fourth pole current transformer with grounding fault protection for a 3-pole circuit breaker
6. Safety baffle

M-PACT Air circuit breaker-Type A 50kA

Withdrawable circuit breaker - including the body and cassette of the circuit breaker, providing rear connection terminals.
 Fixed circuit breaker - The circuit breaker body defaults to a rear horizontal terminal block.

Fixed and Withdrawable Breakers



Frame	Rating (A)	Poles	Withdrawable	Fixed
			Cat. no.	Cat. no.
1	400	3	MPA31W04	MPA31F04
		4	MPA41W04	MPA41F04
1	800	3	MPA31W08	MPA31F08
		4	MPA41W08	MPA41F08
1	1000	3	MPA31W10	MPA31F10
		4	MPA41W10	MPA41F10
1	1250	3	MPA31W12	MPA31F12
		4	MPA41W12	MPA41F12
1	1600	3	MPA31W16	MPA31F16
		4	MPA41W16	MPA41F16
1	2000	3	MPA31W20	MPA31F20
		4	MPA41W20	MPA41F20
1	2500	3	MPA31W25	MPA31F25
		4	MPA41W25	MPA41F25
2	3200	3	MPA32W32	MPA32F32
		4	MPA42W32	MPA42F32
2	4000	3	MPA32W40	MPA32F40
		4	MPA42W40	MPA42F40

Installation: Products smaller than 1600A have smaller copper bar sizes, as shown in section for external dimensions.

Rear connections "T" terminal (Cassette)

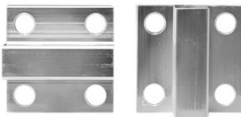

Frame	Rating (A)	Poles	Quantity required	Cat. no.	Remark
1	400 to 1600	3	6	RT1HOR	Horizontal
		4	8	RT1HOR	Horizontal
1	400 to 1600	3	6	RT1VER	Vertical
		4	8	RT1VER	Vertical
1	2000 & 2500	3	6	RT1UNI	Universal
		4	8	RT1UNI	Universal
2	3200	3	6	RT2UNI	Universal
		4	8	RT2UNI	Universal
2	4000	3	6	N/A	Vertical
		4	8	N/A	Vertical

Front connections



Frame	Rating (A)	Poles	Withdrawable	
			Top connections	Bottom connections
			Cat. no.	Cat. no.
1	400 to 1600	3	FA31WA16T	FA31WA16B
		4	FA41WA16T	FA41WA16B
1	2000 to 2500	3	FA31WA25T	FA31WA25B
		4	FA41WA25T	FA41WA25B
2	3200	3	FA32WA32T	FA32WA32B
		4	FA42WA32T	FA42WA32B
2	4000	3	FA32WA40T	FA32WA40B
		4	FA42WA40T	FA42WA40B

Order codes

A

B

C

Front connections

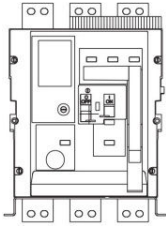

Frame	Rating (A)	Poles	Fixed	
			Top connections	Bottom connections
			Cat. no.	Cat. no.
1	400 to 1600	3	FA31FA16T	FA31FA16B
		4	FA41FA16T	FA41FA16B
1	2000 to 2500	3	FA31FA25T	FA31FA25B
		4	FA41FA25T	FA41FA25B
2	3200	3	FA32FA32T	FA32FA32B
		4	FA42FA32T	FA42FA32B
2	4000	3	FA32FA40T	FA32FA40B
		4	FA42FA40T	FA42FA40B

Cassette only



Basic cassette with flat copper terminals rear connected

Frame	Rating (A)	Poles	Cat. no.
1	400 to 1600	3	MPA31C16
		4	MPA41C16
1	2000 to 2500	3	MPA31C25
		4	MPA41C25
2	3200	3	MPA32C32
		4	MPA42C32
2	4000	3	MPA32C40
		4	MPA42C40

Moving portion only



Standard configuration - auxiliary contact with 5 NO and 3 NC

Frame	Rating (A)	Poles	Cat. no.
1	400	3	MPA31M04
		4	MPA41M04
1	800	3	MPA31M08
		4	MPA41M08
1	1000	3	MPA31M10
		4	MPA41M10
1	1250	3	MPA31M12
		4	MPA41M12
1	1600	3	MPA31M16
		4	MPA41M16
1	2000	3	MPA31M20
		4	MPA41M20
1	2500	3	MPA31M25
		4	MPA41M25
2	3200	3	MPA32M32
		4	MPA42M32
2	4000	3	MPA32M40
		4	MPA42M40

M-PACT Air circuit breaker-Type D 70kA

Withdrawable circuit breaker - including the body and cassette of the circuit breaker, providing rear connection terminals.
 Fixed circuit breaker - The circuit breaker body defaults to a rear horizontal terminal block.

Order codes

A

B

C



Fixed and Withdrawable Breakers

Frame	Rating (A)	Poles	Withdrawable	Fixed
			Cat. no.	Cat. no.
1	400	3	MPD31W04	MPD31F04
		4	MPD41W04	MPD41F04
1	800	3	MPD31W08	MPD31F08
		4	MPD41W08	MPD41F08
1	1000	3	MPD31W10	MPD31F10
		4	MPD41W10	MPD41F10
1	1250	3	MPD31W12	MPD31F12
		4	MPD41W12	MPD41F12
1	1600	3	MPD31W16	MPD31F16
		4	MPD41W16	MPD41F16
1	2000	3	MPD31W20	MPD31F20
		4	MPD41W20	MPD41F20
1	2500	3	MPD31W25	MPD31F25
		4	MPD41W25	MPD41F25
2	3200	3	MPD32W32	MPD32F32
		4	MPD42W32	MPD42F32
2	4000	3	MPD32W40	MPD32F40
		4	MPD42W40	MPD42F40

Rear connections "T" terminal (Cassette)

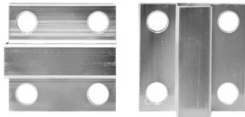

Frame	Rating (A)	Poles	Quantity required	Cat. no.	Remark
1	400 to 1600	3	6	RT1UOR	Universal
		4	8	RT1UOR	Universal
2	3200	3	6	RT2UNI	Universal
		4	8	RT2UNI	Universal
2	4000	3	6	N/A	Vertical
		4	8	N/A	Vertical

Front connections

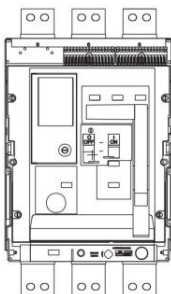

Frame	Rating (A)	Poles	Withdrawable	
			TOP connections Cat. no.	Bottom connections Cat. no.
1	400 to 1600	3	FA31WA16T	FA31WA16B
		4	FA41WA16T	FA41WA16B
1	2000 to 2500	3	FA31WA25T	FA31WA25B
		4	FA41WA25T	FA41WA25B
2	3200	3	FA32WA32T	FA32WA32B
		4	FA42WA32T	FA42WA32B
2	4000	3	FA32WA40T	FA32WA40B
		4	FA42WA40T	FA42WA40B

Front connections

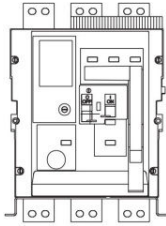

Frame	Rating (A)	Poles	Fixed	
			Top connections	Bottom connections
			Cat. no.	Cat. no.
1	400 to 1600	3	FA31FD16T	FA31FD16B
		4	FA41FD16T	FA41FD16B
1	2000 to 2500	3	FA31FD25T	FA31FD25B
		4	FA41FD25T	FA41FD25B
2	3200	3	FA32FD32T	FA32FD32B
		4	FA42FD32T	FA42FD32B
2	4000	3	FA32FD40T	FA32FD40B
		4	FA42FD40T	FA42FD40B

Cassette only



Basic cassette with flat copper terminals rear connected

Frame	Rating (A)	Poles	Cat. no.
1	400 to 2500	3	MPD31C25
		4	MPD41C25
2	3200	3	MPD32C32
		4	MPD42C32
2	4000	3	MPD32C40
		4	MPD42C40

Moving portion only



Standard configuration - auxiliary contact with 5 NO and 3 NC

Frame	Rating (A)	Poles	Cat. no.
1	400	3	MPD31M04
		4	MPD41M04
1	800	3	MPD31M08
		4	MPD41M08
1	1000	3	MPD31M10
		4	MPD41M10
1	1250	3	MPD31M12
		4	MPD41M12
1	1600	3	MPD31M16
		4	MPD41M16
1	2000	3	MPD31M20
		4	MPD41M20
1	2500	3	MPD31M25
		4	MPD41M25
2	3200	3	MPD32M32
		4	MPD42M32
2	4000	3	MPD32M40
		4	MPD42M40

M-PACT Air circuit breaker-Type H1, H2-80kA

Withdrawable circuit breaker - including the body and cassette of the circuit breaker, providing rear connection terminals.

Fixed circuit breaker - The circuit breaker body defaults to a rear horizontal terminal block.

Order codes

A



Fixed and Withdrawable Breakers

Frame	Rating (A)	Poles	Withdrawable	Fixed	Withdrawable	Fixed
			Cat. no.	Cat. no.	Cat. no.	Cat. no.
2	800	3	MPH32W08	MPH32F08	MPH232W08	MPH232F08
		4	MPH42W08	MPH42F08	MPH242W08	MPH242F08
2	1000	3	MPH32W10	MPH32F10	MPH232W10	MPH232F10
		4	MPH42W10	MPH42F10	MPH242W10	MPH242F10
2	1250	3	MPH42W12	MPH32F12	MPH232W12	MPH232F12
		4	MPH42W12	MPH42F12	MPH242W12	MPH242F12
2	1600	3	MPH32W16	MPH32F16	MPH232W16	MPH232F16
		4	MPH42W16	MPH42F16	MPH242W16	MPH242F16
2	2000	3	MPH32W20	MPH32F20	MPH232W20	MPH232F20
		4	MPH42W20	MPH42F20	MPH242W20	MPH242F20
2	2500	3	MPH32W25	MPH32F25	MPH232W25	MPH232F25
		4	MPH42W25	MPH42F25	MPH242W25	MPH242F25
2	3200	3	MPH32W32	MPH32F32	MPH232W32	MPH232F32
		4	MPH42W32	MPH42F32	MPH242W32	MPH242F32
2	4000	3	MPH32W40	MPH32F40	MPH232W40	MPH232F40
		4	MPH42W40	MPH42F40	MPH242W40	MPH242F40

B

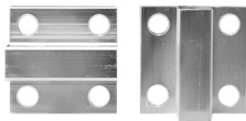

Rear connections "T" terminal (Cassette)

Frame	Rating (A)	Poles	Quantity required	Cat. no.
2	800 - 3200	3	6	RT2UNI
		4	8	RT2UNI
2	4000	3	6	N/A
		4	8	N/A

C

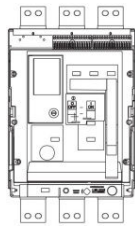

Front connections

Frame	Rating (A)	Poles	Withdrawable	
			Top connections	Bottom connections
			Cat. no.	Cat. no.
2	800 - 3200	3	FA42WH32T	FA32WH32B
		4	FA42WH32T	FA42WH32B
2	4000	3	FA32WH40T	FA42WH40B
		4	FA42WH40T	FA42WH40B

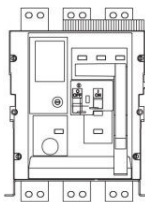

Front connections

Frame	Rating (A)	Poles	Fixed	
			Top connections	Bottom connections
			Cat. no.	Cat. no.
2	800 - 3200	3	FA32FH32T	FA32FH32B
		4	FA42FH32T	FA42FH32B
2	4000	3	FA32FH40T	FA32FH40B
		4	FA42FH40T	FA42FH40B



Cassette only

Basic cassette with flat copper terminals rear connected

Frame	Rating (A)	Poles	Cat. no.	
2	800 - 3200	3	MPH32C32	
		4	MPH42C32	
2	4000	3	MPH32C40	
		4	MPH42C40	



Moving portion only

Standard configuration - auxiliary contact with 5 NO and 3 NC

Frame	Rating (A)	Poles	Cat. no.	Cat. no.
2	800	3	MPH32M08	MPH232M08
		4	MPH42M08	MPH242M08
2	1000	3	MPH32M10	MPH232M10
		4	MPH42M10	MPH242M10
2	1250	3	MPH32M12	MPH232M12
		4	MPH42M12	MPH242M12
2	1600	3	MPH32M16	MPH232M16
		4	MPH42M16	MPH242M16
2	2000	3	MPH32M20	MPH232M20
		4	MPH42M20	MPH242M20
2	2500	3	MPH32M25	MPH232M25
		4	MPH42M25	MPH242M25
2	3200	3	MPH32M32	MPH232M32
		4	MPH42M32	MPH242M32
2	4000	3	MPH32M40	MPH232M40
		4	MPH42M40	MPH242M40

A

B

C



Electrical accessories

	Range	Voltage	Cat. no.	Ref. No.
Shunt Trip (ST)	24/30 V	DC	ST30	B40006554
	48 V	DC	ST48	B40006555
	110/130 V	AC/DC	ST130	B40006401
	220/250 V	AC/DC	ST250	B40006500
	380/440 V	AC	ST440	B40006497
Motor operator (MOP)	24/30 V	DC	MOP30	B40029600
	48 V	DC	MOP48	B40029601
	110/130 V	AC/DC	MOP130	B40033630
	220/250 V	AC/DC	MOP250	B40032398
Closing Coil (CC)	380/440 V	AC	MOP440A	B90000018
	24/30 V	DC	CC30	B40006556
	48 V	DC	CC48	B40006557
	110/130 V	AC/DC	CC130	B40006402
	220/250 V	AC/DC	CC250	B40006498
Undervoltage release (UV)	300/440 V	AC	CC440	B90000018
	48 V	DC	UV48	B40027558
	110/130 V	AC	UV130A	B40027559
	110/130 V	DC	UV130D	B40027570
	220/250 V	AC	UV250	B40033628
Undervoltage release Time Delayed (UVTD)	380/440 V	AC	UV440	B40006578
	48 V	DC	UVTD48	B40027571
	220/250 V	AC	UVTD250	B40006576
	380/440 V	AC	UVTD440	B40006580
Springs charged signal (1 x NO)	250 V	AC/DC	CSWFF	B40011377
			SCC	
Provided as a standard accessory for energy storage motors				

Note: If you need accessories for 5000-6400A, please contact your local office.

Accessories

Mechanical accessories

1-2 interlock/cable			Type A		1-3 interlock/cable			Type B	
Frame	Version	Poles	Cat.no.	Ref.No.	Frame	Version	Poles	Cat.no.	Ref.No.
1	Withdrawable	3	2WCI3PW	406342	1	Withdrawable	3	B13WCI3PW	406350
1		4	2WCI4PW	406343	1		4	B13WCI4PW	406351
2		3	2WCI3PW	405459	2		3	B13WCIF23PW	405475
2		4	2WCI4PW	405461	2		4	B13WCIF24PW	405477
1	Fixed	3	2WCI3PF	406340	1	Fixed	3	B13WCI3PF	406348
1		4	2WCI4PF	406341	1		4	B13WCI4PF	406349
2		3	2WCI3PF	405463	2		3	B13WCIF23PF	405479
2		4	2WCI4PF	405465	2		4	B13WCIF24PF	405481

2-3 interlock/cable			Type C	
Frame	Version	Poles	Cat.no.	Ref.No.
1	Withdrawable	3	C23WCI3PW	406358
1		4	C23WCI4PW	406359
2		3	C23WCIF23PW	405491
2		4	C23WCIF24PW	405493
1	Fixed	3	C23WCI3PF	406356
1		4	C23WCI4PF	406357
2		3	C23WCIF23PF	405495
2		4	C23WCIF24PF	405497

Cable for interlock

Item	Cat.no.	Ref.No.
cable, 100cm	100BCMCI	405531
cable, 160cm	160BCMCI	405532
cable, 200cm	200BCMCI	405533
cable, 300cm	300BCMCI	405611

Note: If you need longer mechanical interlocking steel cables, please contact us.

Interlocks			Others		
Item	Cat.no.	Ref.No.	Item	Cat.no.	Ref.No.
			Operations counter	MOC	B40006511
			Left hand door interlock - hinged left	DILHS	B40006546
			Right hand door interlock - hinged right	DIRHS	B40006504
Roins key breaker interlock ⁽¹⁾	RONLOK	B40006515	Mis-insertion device	ACBMID	B40006503
Ronis key cassette interlock (factory fitted)	RONCASFF	B40011378	IP54 door	IP54DOOR	B40006507
			Handling (lifting) truck	ACBLIFT	B40006832
			Trip alarm contact	MPROMAC	B40006573

(1) There are 4 types of lock cores available for selection (A, B, C, D). Please indicate the lock cores (A, B, C, D) after the order number when placing an order.

Frame 1,2

Spare parts

Neutral / Earth leg (4th) ⁽¹⁾ Current transformer with mounting kit		Neutral (4th) Rogowski coil with mounting kit ⁽²⁾			
Frame	Rating (A)	Current transformer		Rogowski coil ⁽²⁾	
		Cat.no.	Ref.No.	Cat.no.	Ref.No.
1	800	ELCT8001		RCMK8001	
2		ELCT8002		RCMK8002	
1	1000	ELCT10001		RCMK10001	
2		ELCT10002		RCMK10002	
1	1250	ELCT12501		RCMK12501	
2		ELCT12502		RCMK12502	
1	1600	ELCT16001		RCMK16001	
2		ELCT16002		RCMK16002	
1	2000	ELCT20001		RCMK20001	
2		ELCT20002		RCMK20002	
1	2500	ELCT25001		RCMK25001	
2		ELCT25002		RCMK25002	
2	3200	ELCT32002		RCMK32002	
2	4000	ELCT40002		RCMK40002	



(1) The grounding current transformer is used in conjunction with electronic release devices to achieve GF CT function. This accessories needs to be purchased separately and is not provided as a standard accessories. If necessary, please contact your local sales.

(2) Simultaneously provide output twisted pair cables (length ≤ 2m). The fourth pole neutral current transformer used for ground fault protection is standard configuration. If you need to order an independent fourth pole neutral current transformer, please contact your local sales.

Air circuit breaker 400A-6400A

Technical data

Order codes

Wiring diagrams

- C.2 Mpro21/22/31/32/41/42 Wiring diagrams
- C.3 MproA13/A16P13H/P16H Wiring diagrams

A

B

C

M-PACT ACB with Mpro21/22/31/32/41/42 control unit

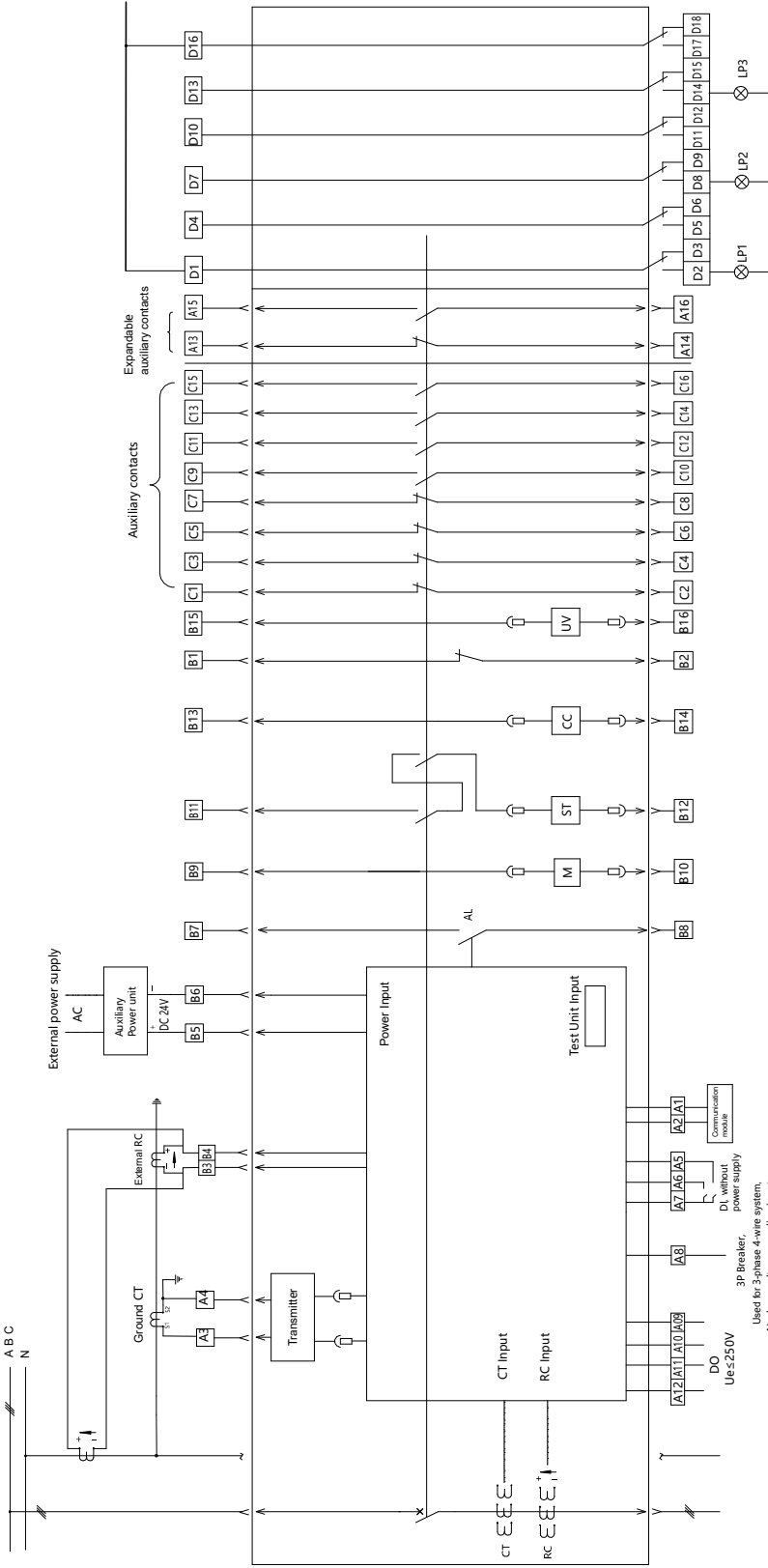

Secondary wiring terminal description

B1-B2	Energy storage signal (closed after energy storage)
B3-B4	External RC of 3P circuit breaker, N-phase current sampling
B5-B6	Auxiliary power supply
B7-B8	Trip alarm contact
B9-B10	Power input for Motor operator
B11-B12	Shunt Trip
B13-B14	Closing Coil
B15-B16	UV / UVTD

C1-C16	Auxiliary contacts, standard for NO+NC. When SNO+3NC, C7/C8 are normally open; When SNO+5NC, C9/C10 are normally closed.
A1-A2	Communication
A3-A4	Grounding CT (applicable only to Mpro32/42)
A5/A6/A7	D11, D12
A8	3P Breaker, Used for 3-phase 4-wire system, N-phase voltage sampling input
A9-A10	DO1
A11-A12	DO2
A13-A16	Expandable auxiliary contacts: NC (A13-A14), NO (A15-A16)

D1-D6	Disconnected indication
D7-D12	Test indication
D13-D18	Connected indication
M	Motor operator
ST	Shunt Trip
CC	Closing Coil
UVR	Undervoltage releaser
UVTD	Time delayed undervoltage release
AL	Trip alarm contact
CT	Power CT
RC	Rogowski coils for measuring
GROUND CT	Ground CT for (SEF)

Warning!

The auxiliary power supply in the wiring diagram of the M-PACT Breaker is an optional accessory and an independently installed module. In any case, the B5-B6 wiring terminals of the M-PACT Breaker can only be connected to a 24VDC power supply (B5+, B6-). If the circuit breaker protection components are burned out due to power wiring errors, our company will not bear responsibility.

Frame 3,5000-6400A, MproA13/A16, MproP13H/P16H Control Unit Wiring Diagram

Terminal A standard wiring diagram

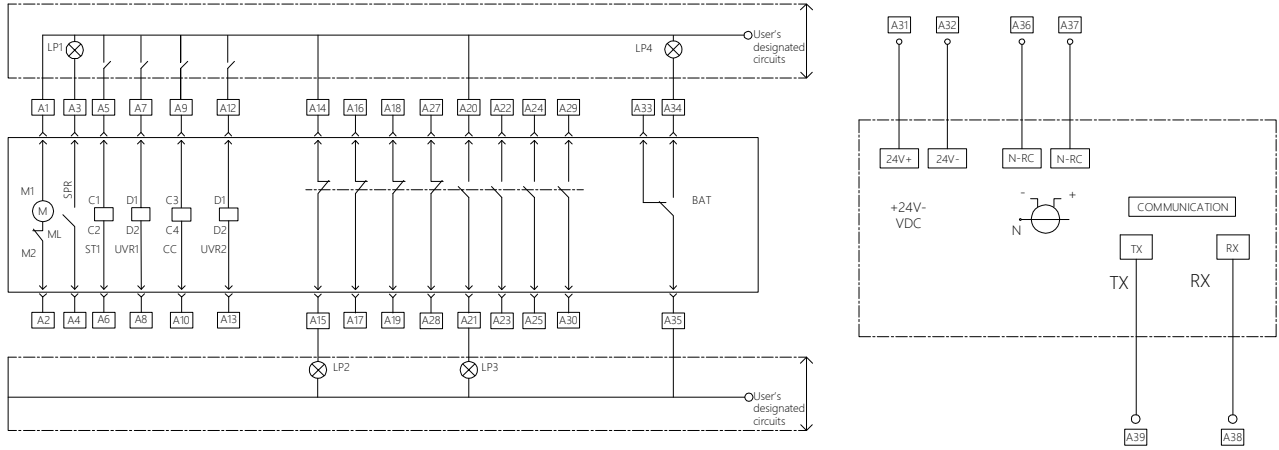

Terminal A wiring diagram for optional function

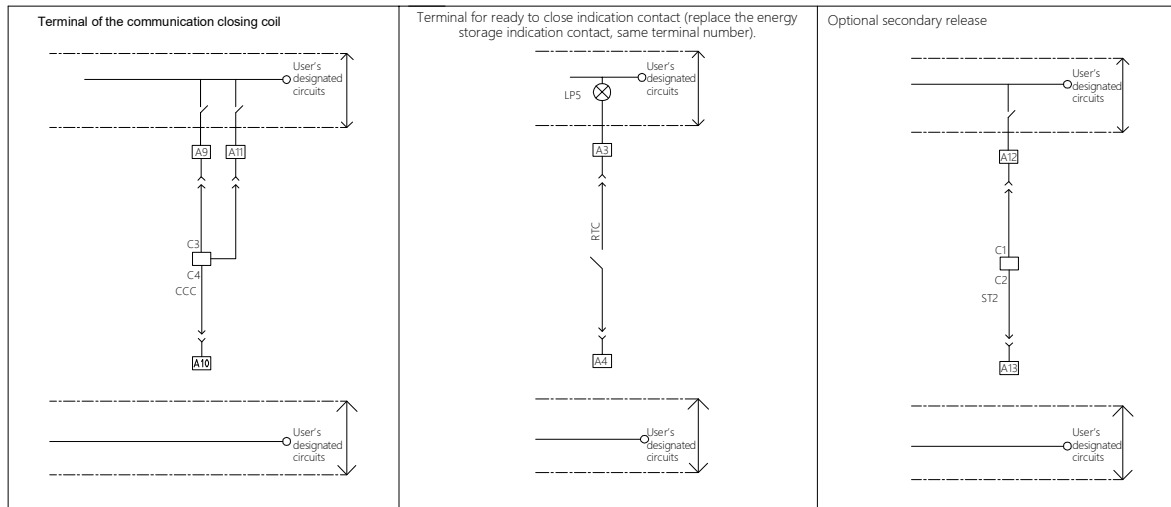

Acronyms explanation:

CC: Closing coil
 ST: Shunt release
 UVR: Undervoltage release
 SPR: Spring status
 RTC: Ready to close
 M: Motor operator
 BAT: Bell alarm trip

CCC: Command Closing Coil
 24V+/24V-: Auxiliary power supply to control unit
 N-RC: External rogowski coil for neutral line
 RXD: Communication terminal
 TXD: Communication terminal
 A14-A19, A27-A28: Normally Closed Contact of the Changeover Switch
 A25, A29-A30: Normally Opened Contact of the Changeover Switch

Frame 3,5000-6400A, MproA13/A16, MproP13H/P16H Control Unit Wiring Diagram

Terminal B standard wiring diagram

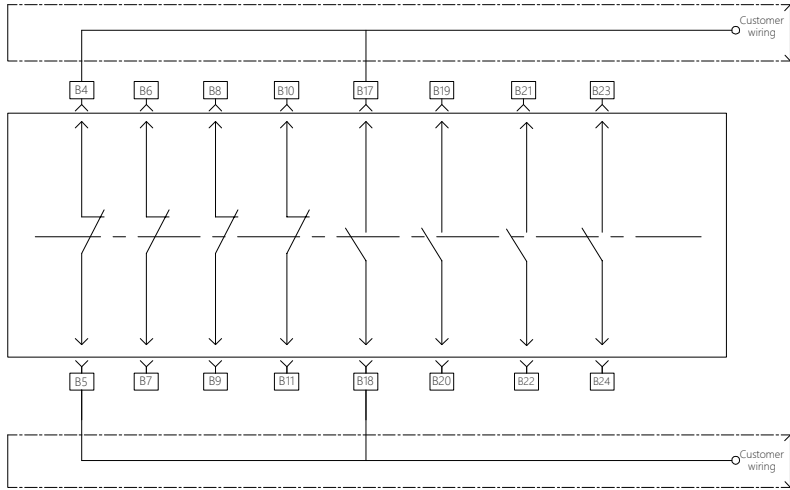

Acronyms explanation:

- ELCT: Earth leg CT input
- RELAY O/P: Relay output
- RELAY I/P: Relay input
- V-A/V-B/V-C: Signal input from voltage conditioner
- GND: Ground for voltage

- ZSI OUT: Zone selective interlock output
- ZSI INPUT: Zone selective input
- B4-B11: Normally Closed Contact of the Changeover Switch
- B17-B24: Normally opened Contact of the Changeover Switch

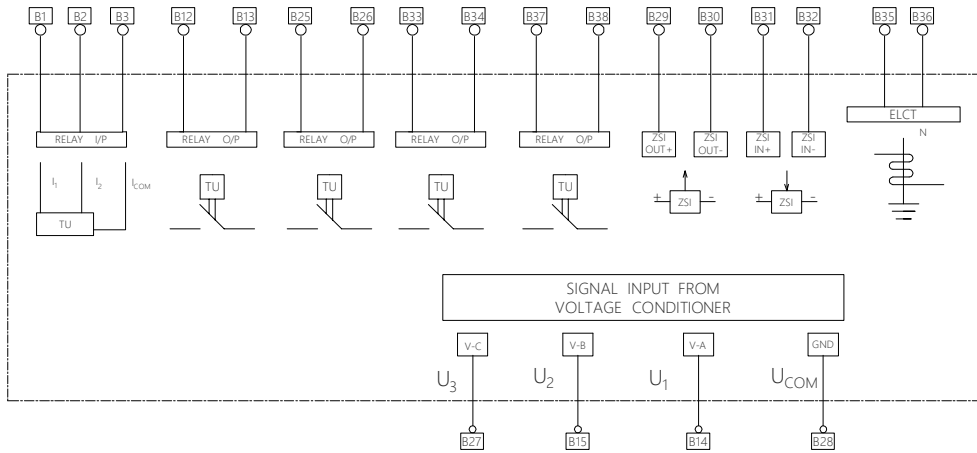

Frame 3, 5000-6400A, Optional indicator for base position

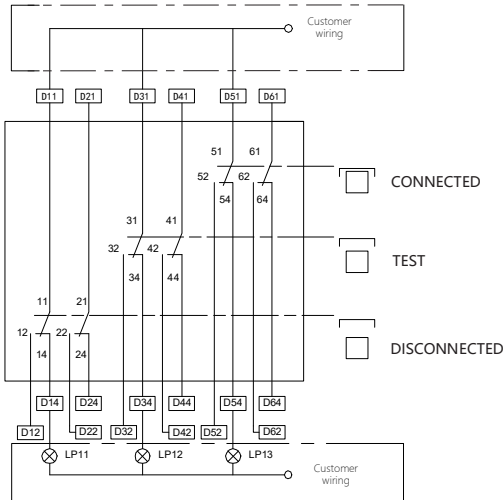

User External Connection Indication

- LP11: Circuit breaker at disconnected position
- LP12: Circuit breaker at test position
- LP13: Circuit breaker at connected position

Air circuit breaker 400A-6400A

Technical data

Order codes

Dimensional drawings

A

B

C

Dimensional drawings

Note: Bottom plate installation hole diameter - fixed type
 Frame 1-9.2mm, it is recommended to use M8x4 bolts of grade 8.8
 Frame 2-11.2mm, it is recommended to use M10x4 bolts of grade 8.8.

Fixed, horizontal, rear connection 3P, Type A, 400A to 1600A

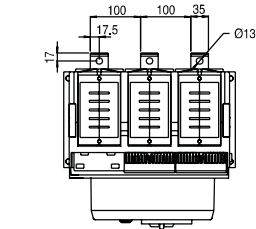

Centre line of operating panel

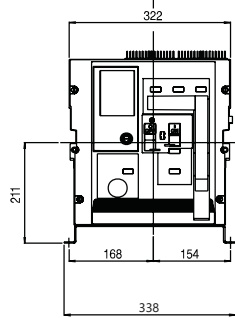

Centre line of operating panel

Minimum space to earth metal and for arc chute removal

Insulated metal or insulated sheet (customer supplied)

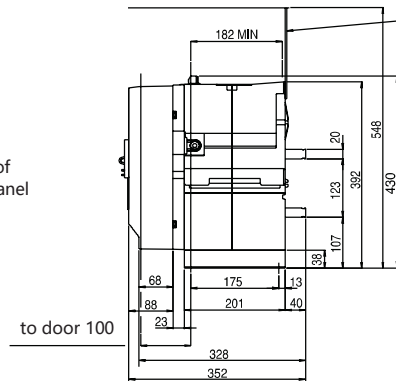

Copperwork must be supported within 200 mm of breaker connections-busbars or cables. All connections to be tightened to 50Nm.

Note: Gap on both sides of the circuit breaker ≥ 25 mm

4P, Type A, 400A to 1600A

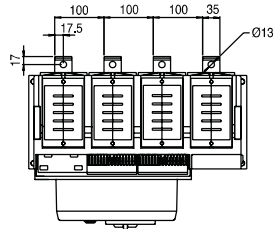

Centre line of operating panel

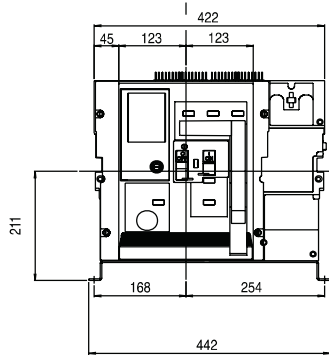

Centre line of operating panel

Minimum space to earth metal and for arc chute removal

Insulated metal or insulated sheet (customer supplied)

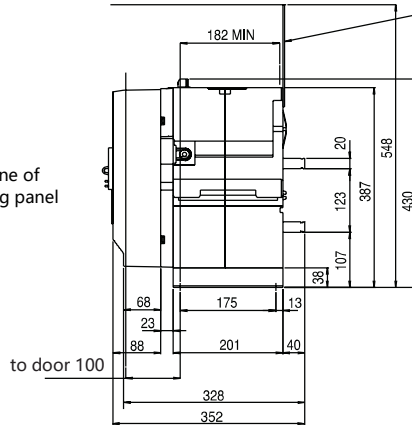

Copperwork must be supported within 200 mm of breaker connections-busbars or cables. All connections to be tightened to 50Nm.

Note: Gap on both sides of the circuit breaker ≥ 25 mm

**Fixed, horizontal, rear connection
3P, Type D, 400A to 1600A**

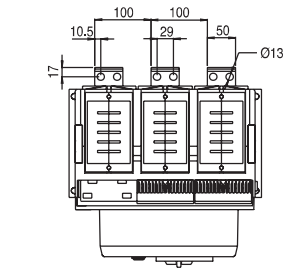

Centre line of operating panel

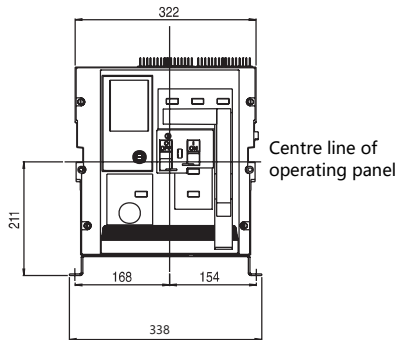

Centre line of operating panel

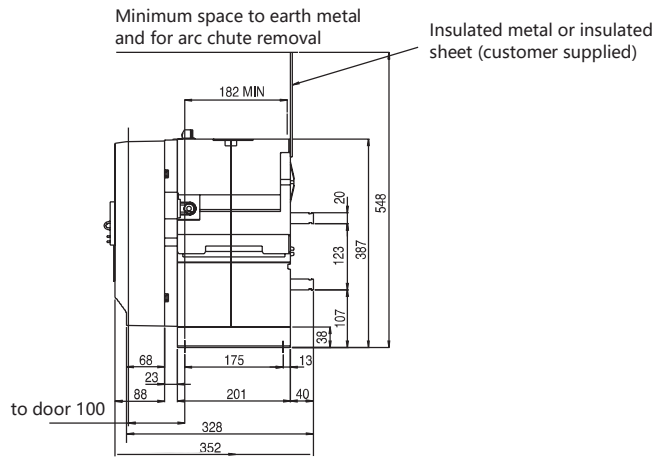

Copperwork must be supported within 200 mm of breaker connections-busbars or cables. All connections to be tightened to 50Nm.
Note: Gap on both sides of the circuit breaker $\geq 25\text{mm}$

4P, Type D, 400A to 1600A

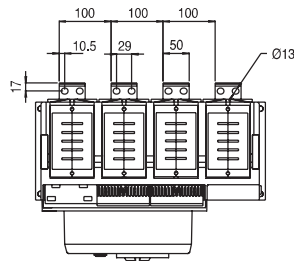

Centre line of operating panel

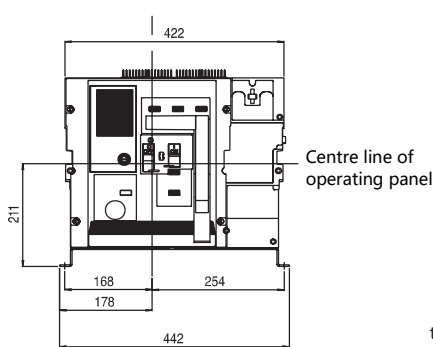

Centre line of operating panel

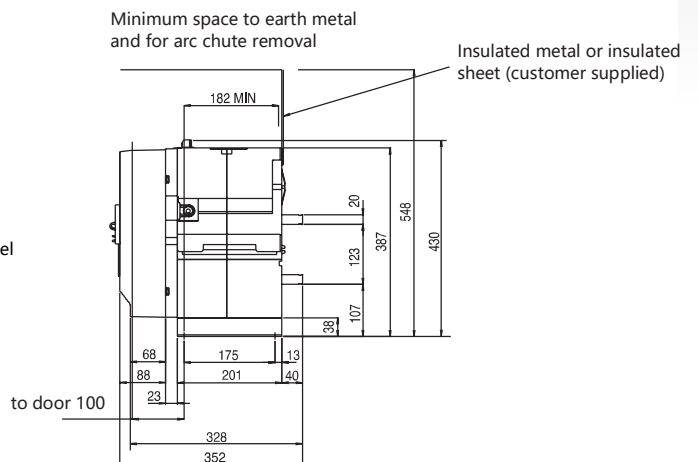

Copperwork must be supported within 200 mm of breaker connections-busbars or cables. All connections to be tightened to 50Nm.
Note: 690V 1600A D-type rear terminal hole reference to 2000/2500A

Gap on both sides of the circuit breaker $\geq 25\text{mm}$

A

B

C

Fixed, horizontal, rear connection

3P, Type A and Type D, 2000A to 2500A; Type D2 400A to 2500A

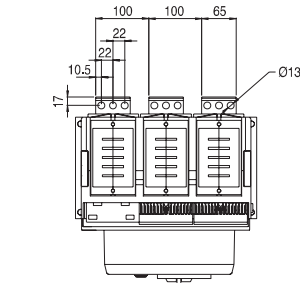

Centre line of operating panel

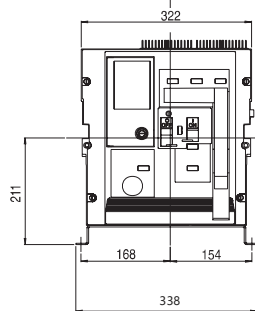

Minimum space to earth metal and for arc chute removal

Insulated metal or insulated sheet (customer supplied)

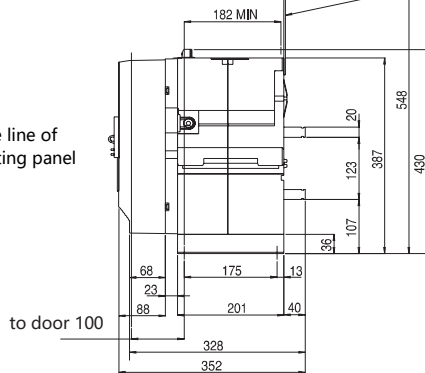

Copperwork must be supported within 200 mm of breaker connections-busbars or cables. All connections to be tightened to 50Nm.

Note: Gap on both sides of the circuit breaker $\geq 25\text{mm}$

4P, Type A and Type D, 2000A to 2500A; Type D2 400A to 2500A

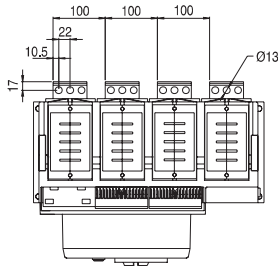

Centre line of operating panel

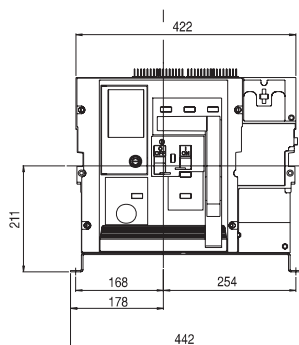

Minimum space to earth metal and for arc chute removal

Insulated metal or insulated sheet (customer supplied)

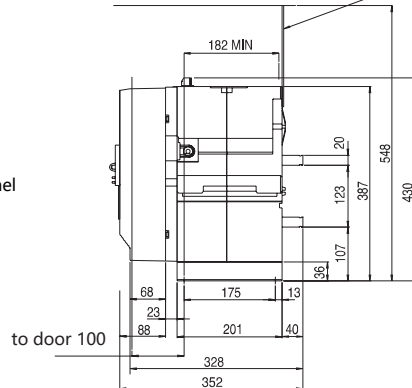

Copperwork must be supported within 200 mm of breaker connections-busbars or cables. All connections to be tightened to 50Nm.

Note: Gap on both sides of the circuit breaker $\geq 25\text{mm}$

Fixed, horizontal, rear connection

3P, Type A and Type D, 3200A to 4000A
3P, Type H₁ and Type H₂, 800A to 4000A

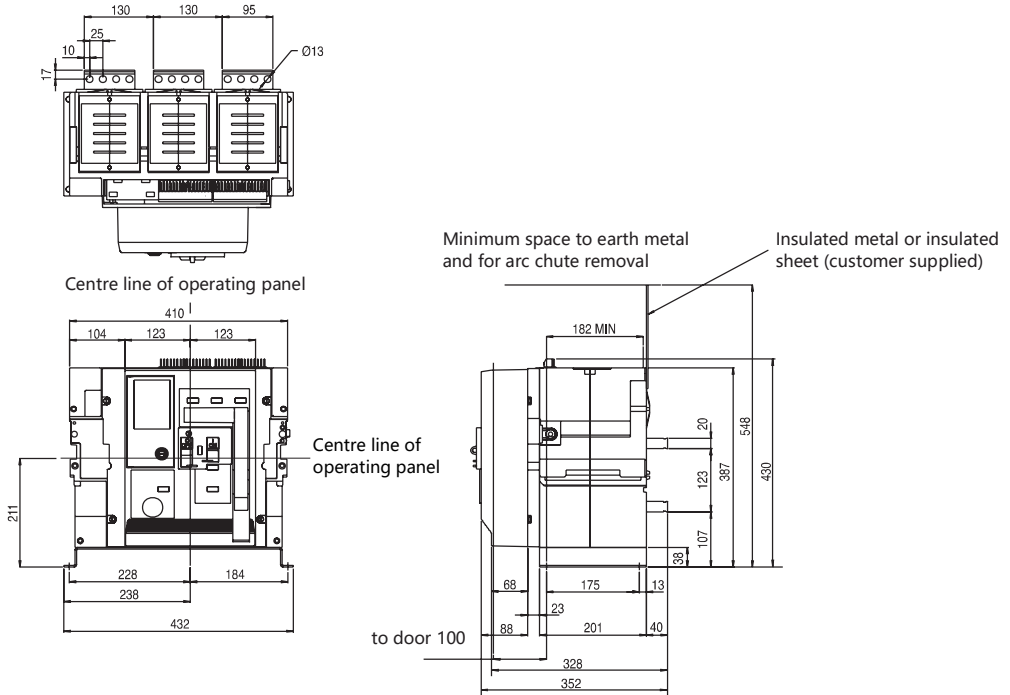

Copperwork must be supported within 200 mm of breaker connections-busbars or cables. All connections to be tightened to 50Nm.

Note: Gap on both sides of the circuit breaker ≥25mm

4P, Type A and Type D, 3200A to 4000A
4P, Type H₁ and Type H₂, 800A to 4000A

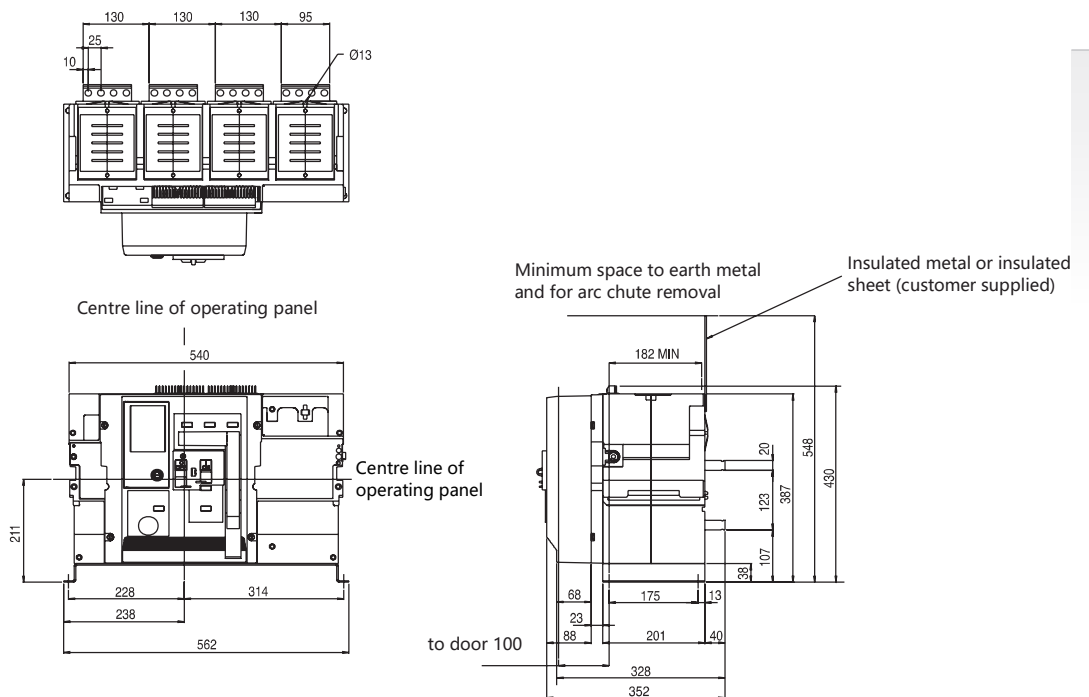

Copperwork must be supported within 200 mm of breaker connections-busbars or cables. All connections to be tightened to 50Nm.

Note: Gap on both sides of the circuit breaker ≥25mm

Withdrawable, rear connection 3P, Type A, 400A to 1600A

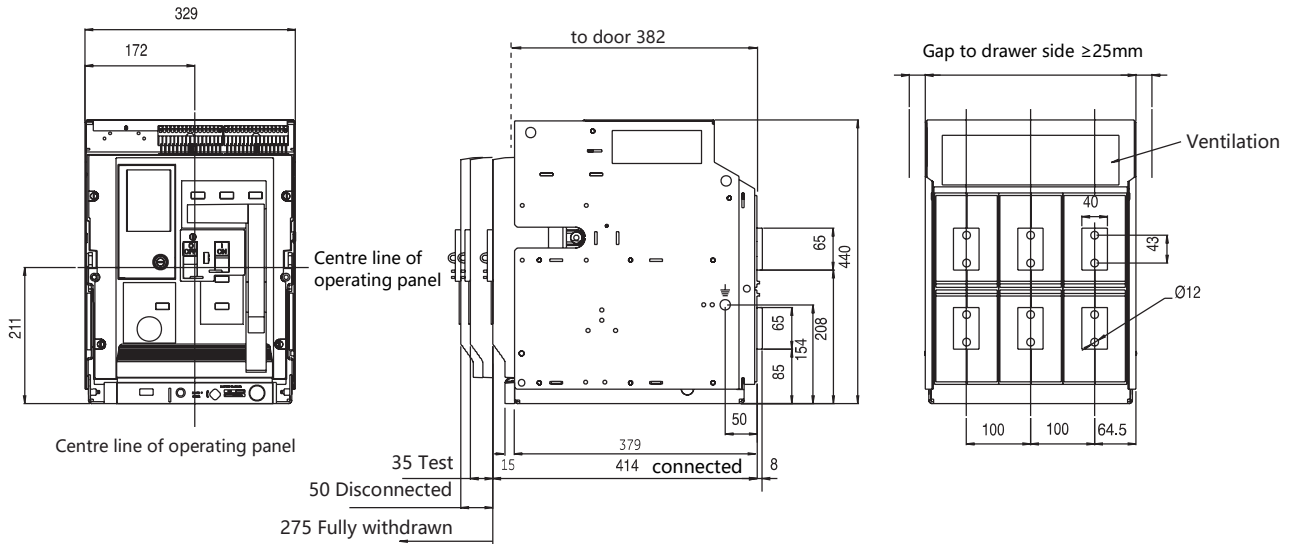

Copperwork must be supported within 200 mm of breaker connections-busbars or cables. All connections to be tightened to 50Nm.

4P, Type A, 400A to 1600A

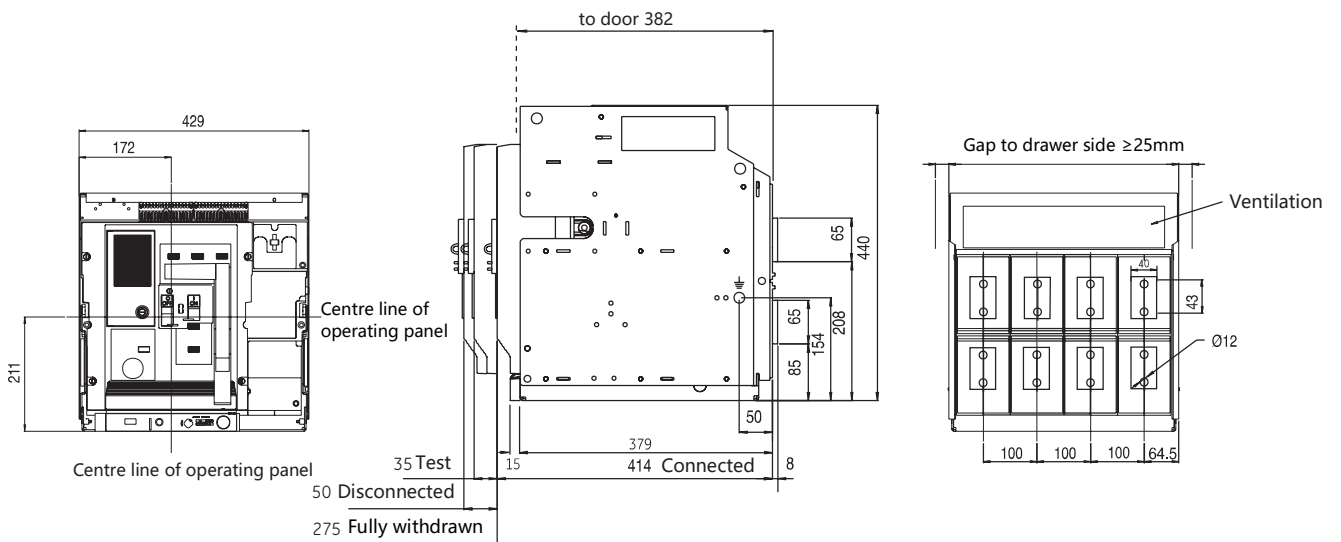

Copperwork must be supported within 200 mm of breaker connections-busbars or cables. All connections to be tightened to 50Nm.

Withdrawable, rear connection

3P, Type A, 2000A to 2500A

3P, Type D and Type D2, 400A to 2500A

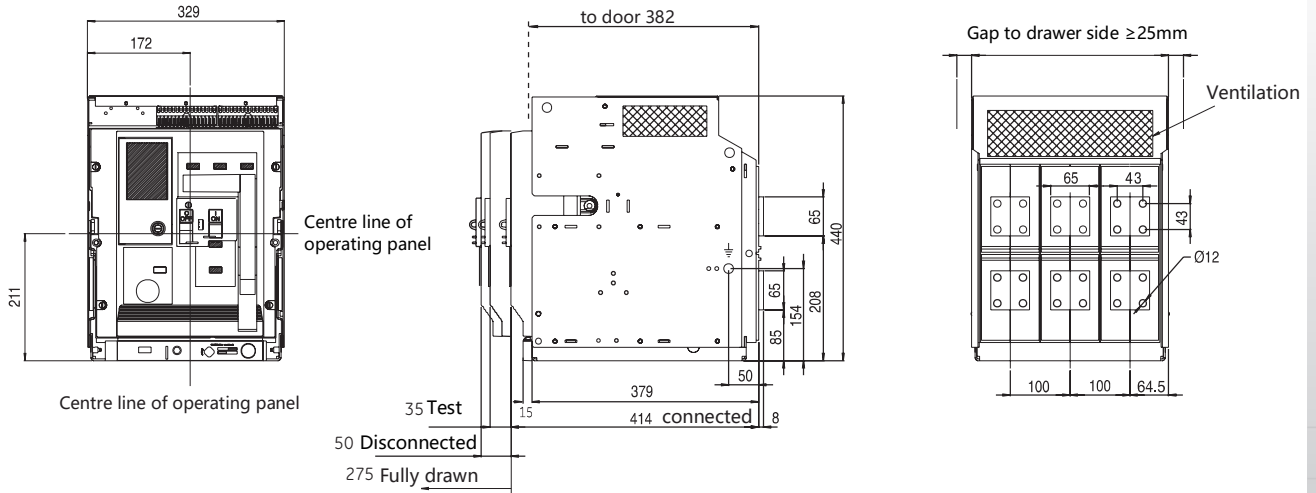

Copperwork must be supported within 200 mm of breaker connections-busbars or cables. All connections to be tightened to 50Nm.

4P, Type A, 2000A to 2500A

4P, Type D and Type D2, 400A to 2500A

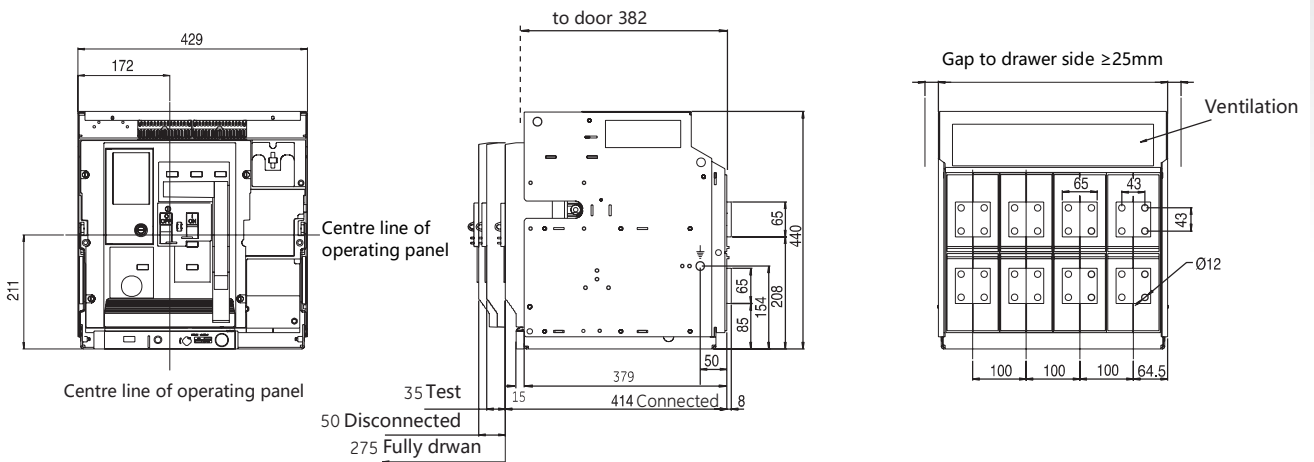

Copperwork must be supported within 200 mm of breaker connections-busbars or cables. All connections to be tightened to 50Nm.

Note: 690V 1600A D-type rear terminal hole reference to 2000/2500A

Withdrawable, rear connection
3P, Type A and Type D, 3200A
3P, Type H₁ and Type H₂, 800 to 3200A

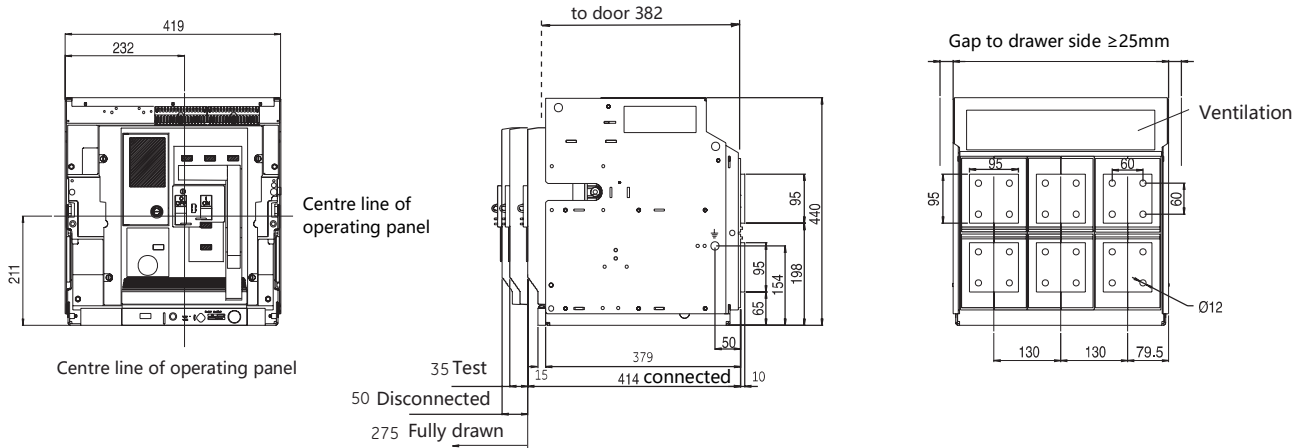

Copperwork must be supported within 200 mm of breaker connections-busbars or cables. All connections to be tightened to 50Nm.

4P, Type A and Type D, 3200A
4P, Type H₁ and Type H₂, 800 to 3200A

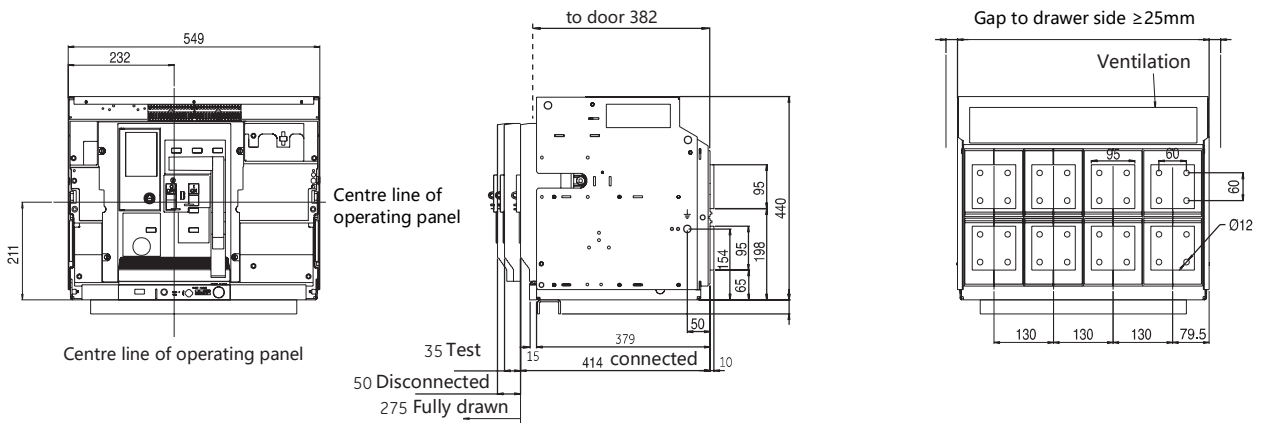

Copperwork must be supported within 200 mm of breaker connections-busbars or cables. All connections to be tightened to 50Nm.

Withdrawable, rear connection

3P, Type A, Type D, Type H, 4000A

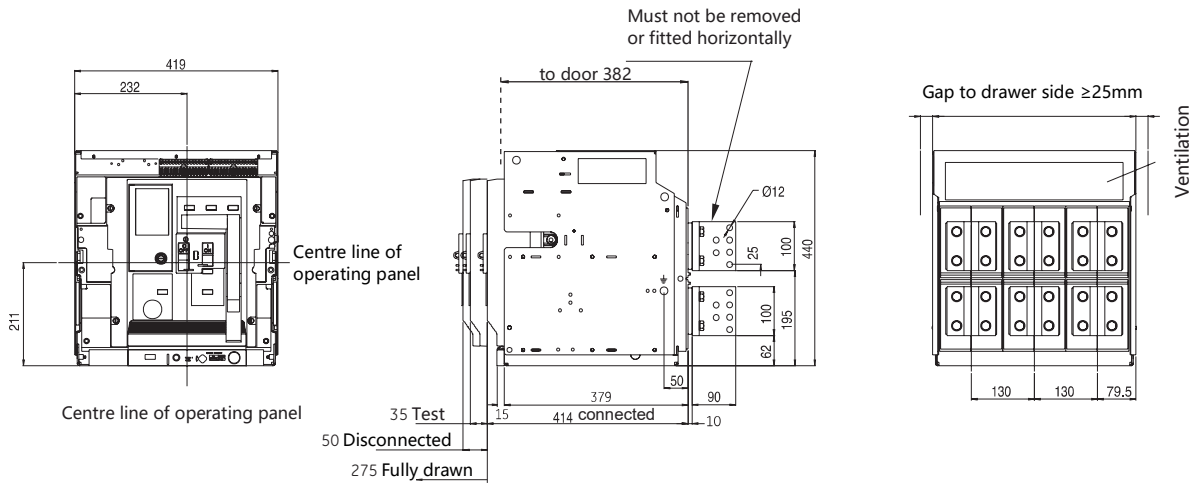

Copperwork must be supported within 200 mm of breaker connections-busbars or cables. All connections to be tightened to 50Nm.

4P, Type A, Type D, Type H, 4000A

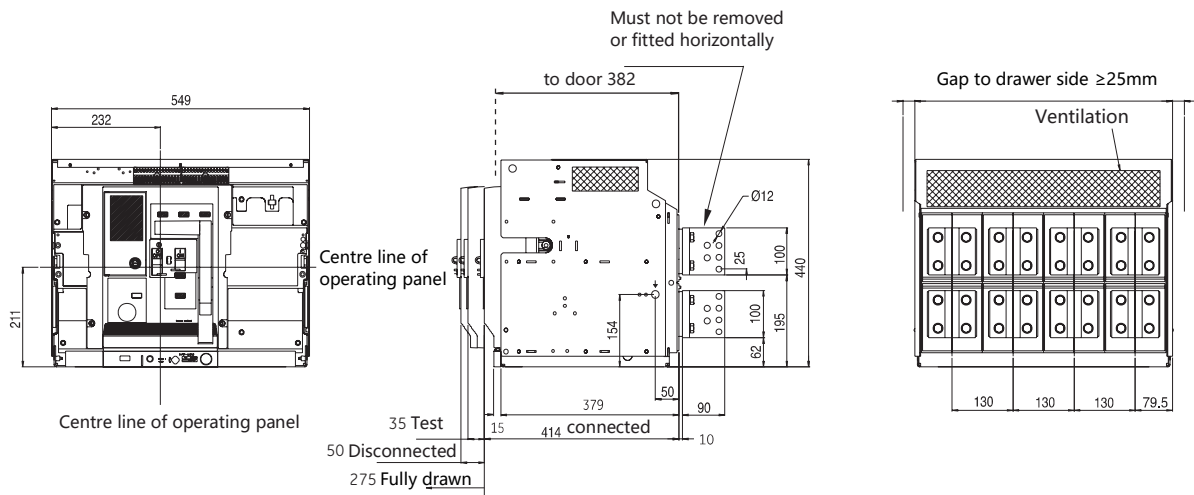

Copperwork must be supported within 200 mm of breaker connections-busbars or cables. All connections to be tightened to 50Nm.

A

B

C

Front access connection of Fixed type

3P, Type A, Type D, 400A to 1600A

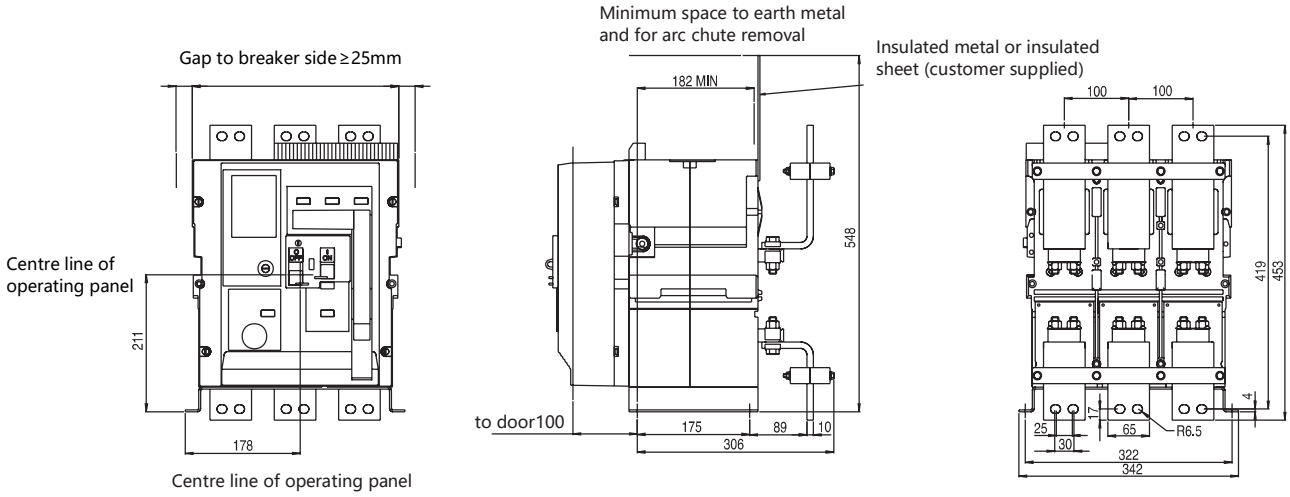

Copperwork must be supported within 200 mm of breaker connections-busbars or cables. All connections to be tightened to 50Nm.

4P, Type A, Type D, 400A to 1600A

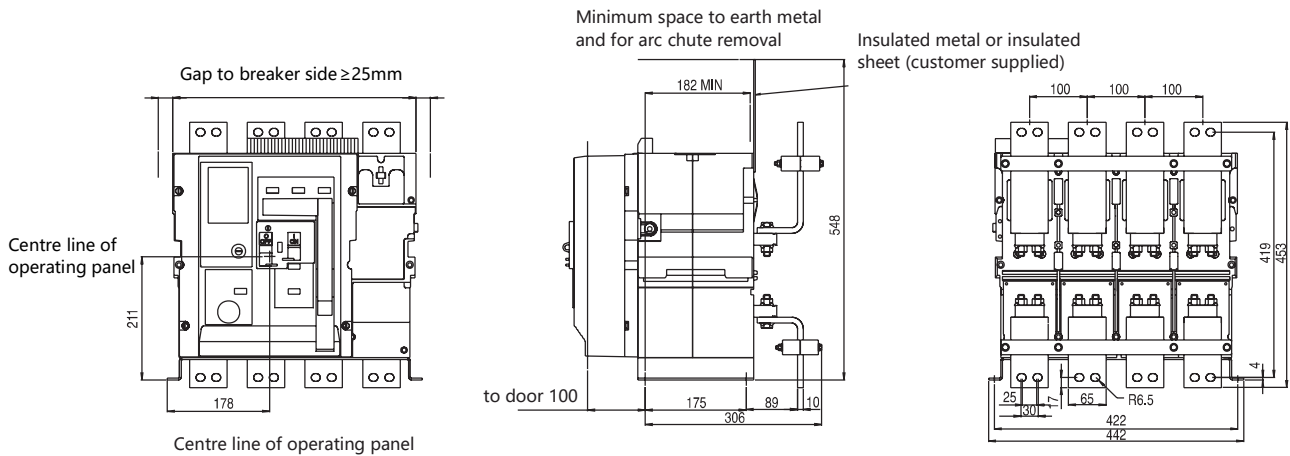

Copperwork must be supported within 200 mm of breaker connections-busbars or cables. All connections to be tightened to 50Nm.

Front access connection of Fixed type

3P, Type A and Type D, 2000A to 2500A, Type D2 400A to 2500A

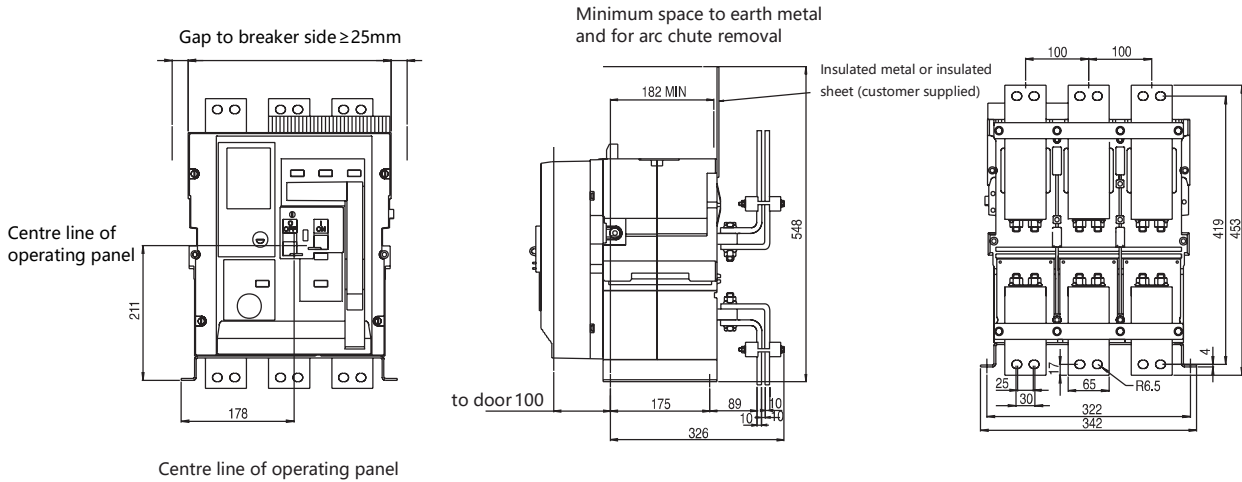

Copperwork must be supported within 200 mm of breaker connections-busbars or cables. All connections to be tightened to 50Nm.

4P, Type A and Type D, 2000A to 2500A, Type D2 400A to 2500A

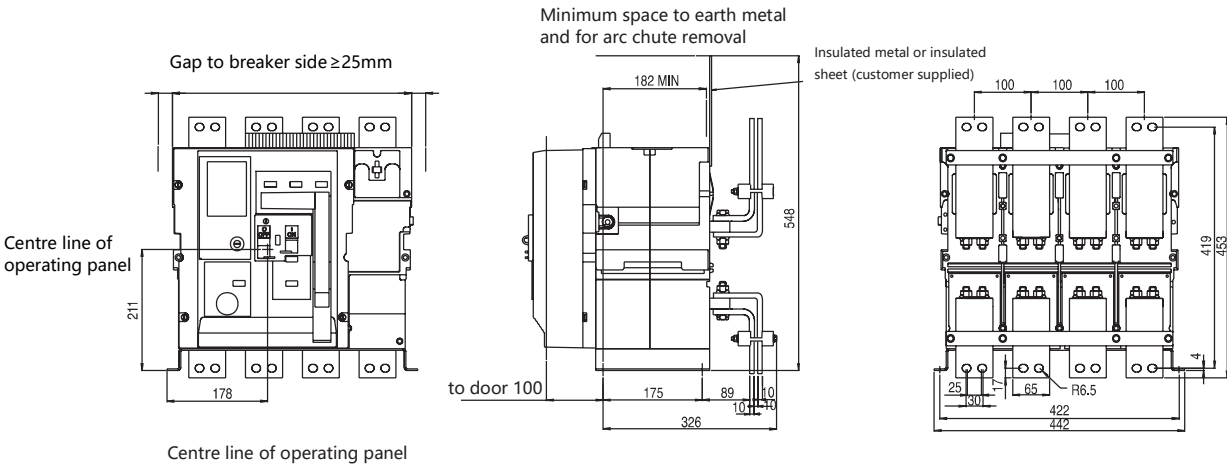

Copperwork must be supported within 200 mm of breaker connections-busbars or cables. All connections to be tightened to 50Nm.

A

B

C

Front access connection of Fixed type

3P, Type A and Type D, 3200A to 4000A
 3P, Type H₁ and Type H₂, 800A to 4000A

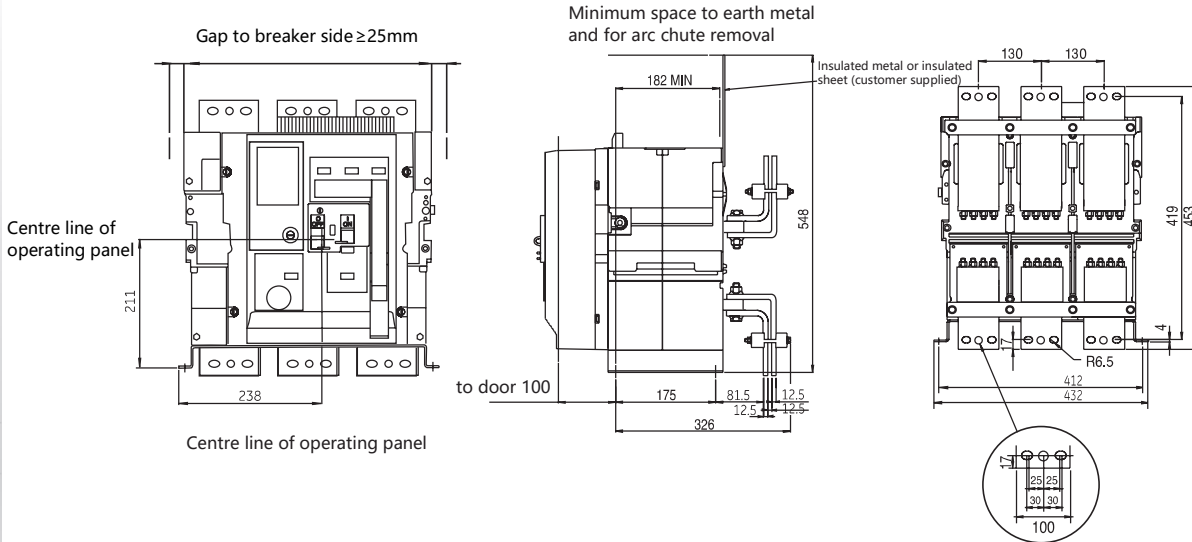

Copperwork must be supported within 200 mm of breaker connections-busbars or cables. All connections to be tightened to 50Nm.

4P, Type A and Type D, 3200A to 4000A
 4P, Type H₁ and Type H₂, 800A to 4000A

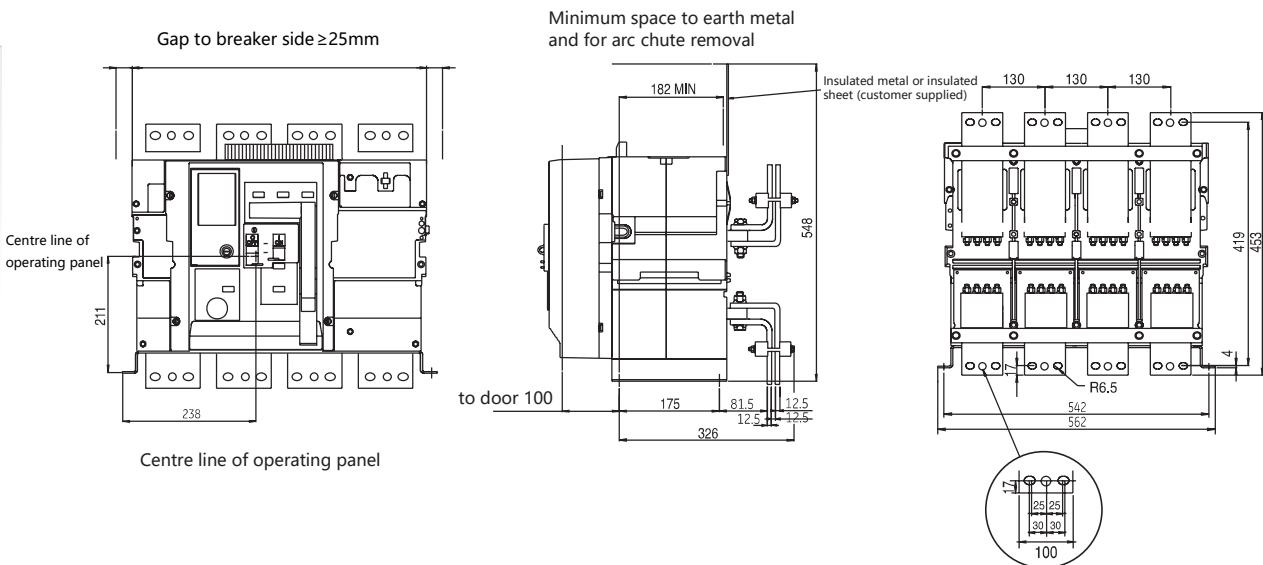

Copperwork must be supported within 200 mm of breaker connections-busbars or cables. All connections to be tightened to 50Nm.

Front access connection of Withdrawable type

3P, Type A and Type D, 400A to 1600A

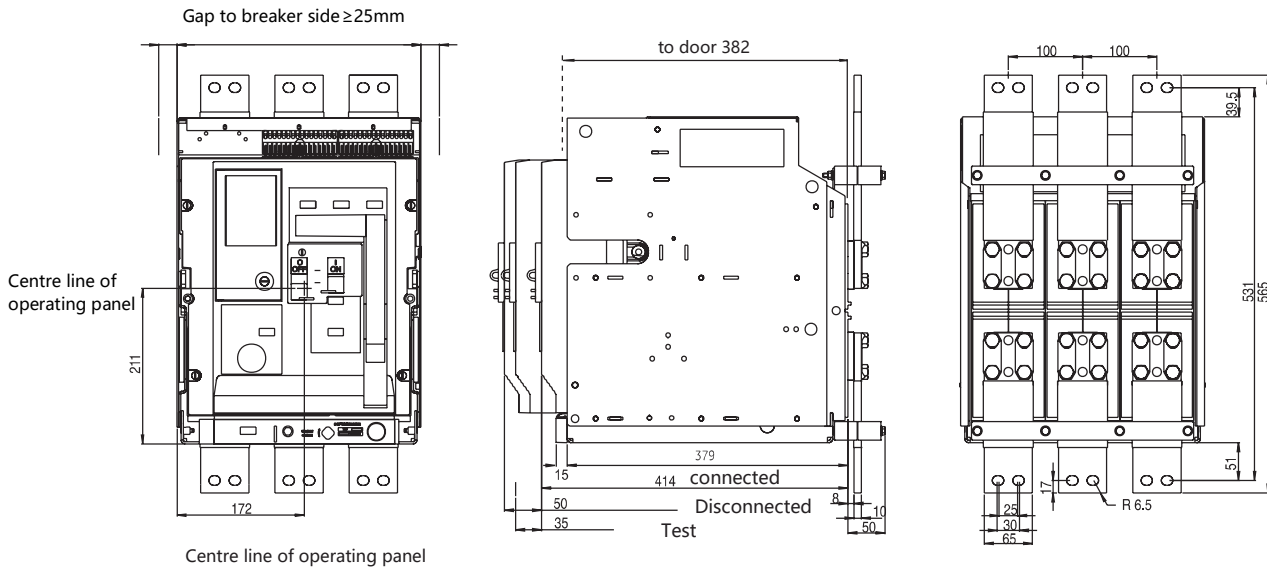

Copperwork must be supported within 200 mm of breaker connections-busbars or cables. All connections to be tightened to 50Nm.

4P, Type A and Type D, 400A to 1600A

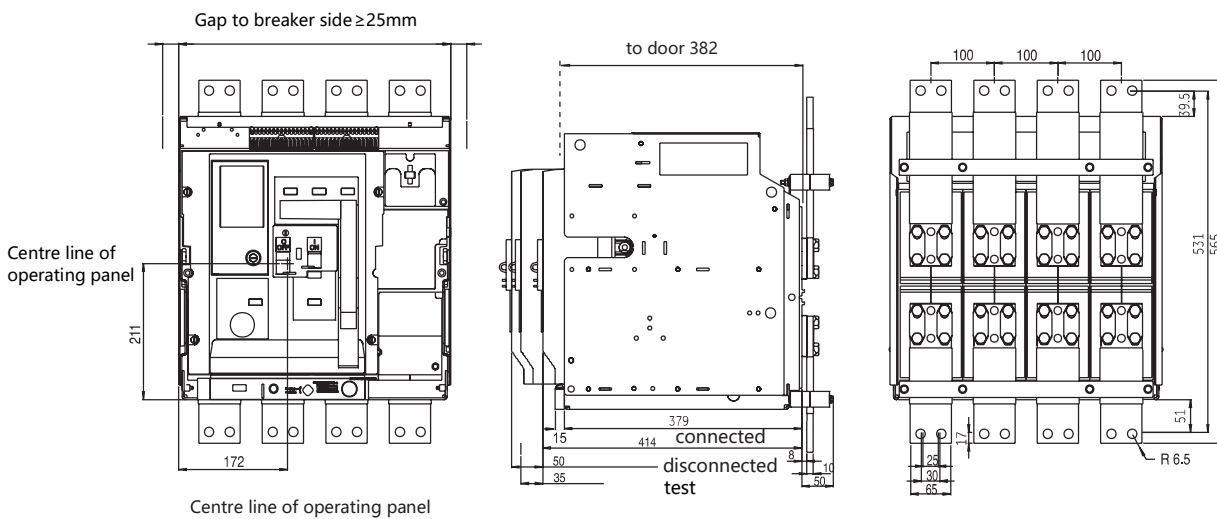

Copperwork must be supported within 200 mm of breaker connections-busbars or cables. All connections to be tightened to 50Nm.

Front access connection of Withdrawable type

3P, Type A and Type D, 2000A to 2500A, Type D2, 400 to 2500A

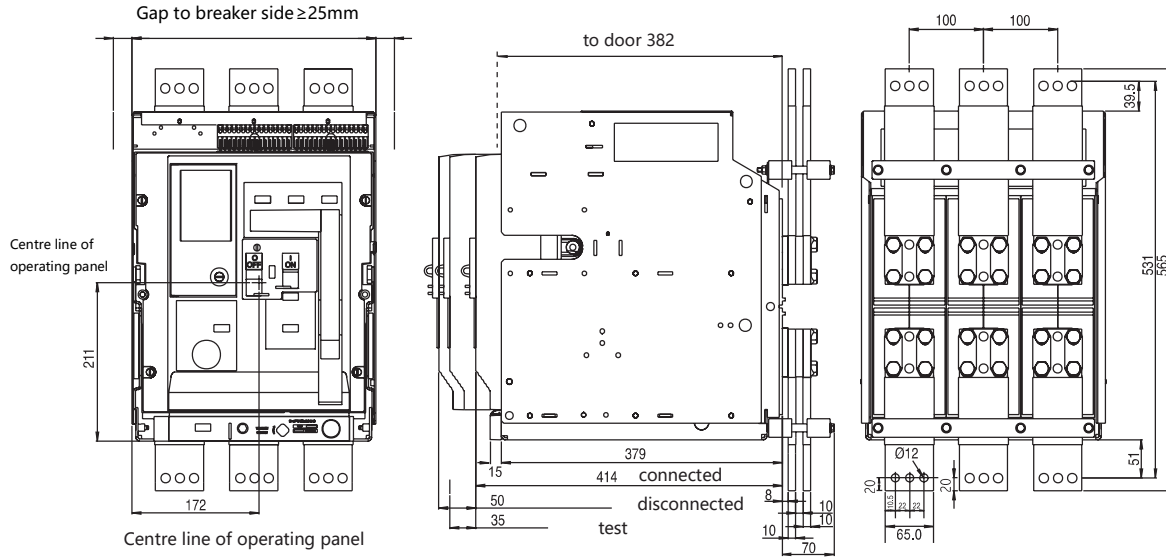

Copperwork must be supported within 200 mm of breaker connections-busbars or cables. All connections to be tightened to 50Nm.

4P, Type A and Type D, 2000A to 2500A, Type D2, 400 to 2500A

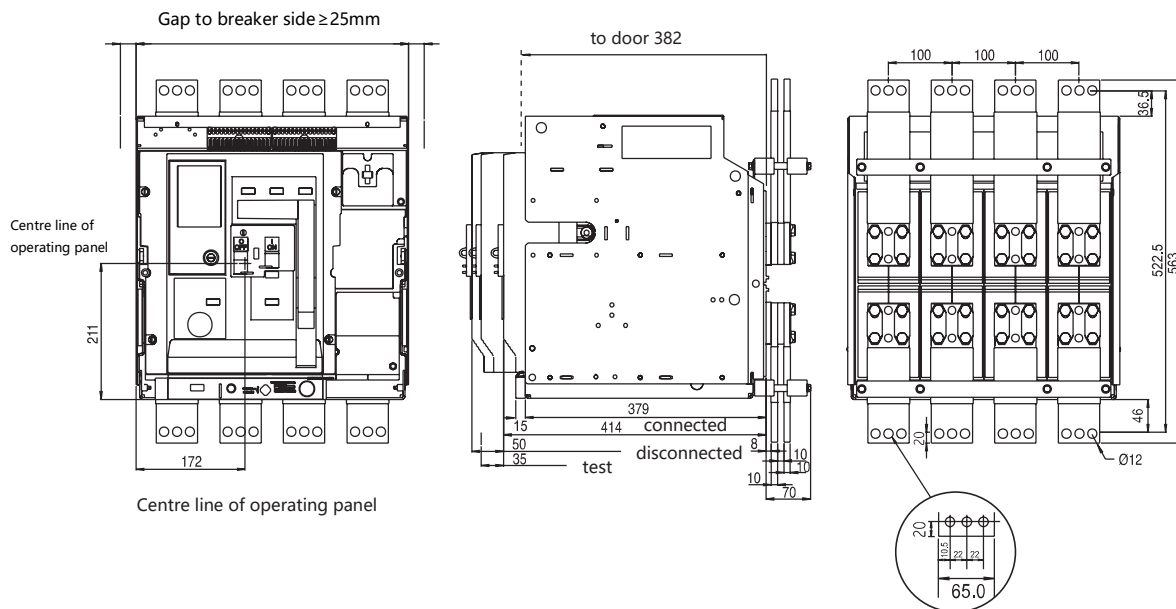

Copperwork must be supported within 200 mm of breaker connections-busbars or cables. All connections to be tightened to 50Nm.

Front access connection of Withdrawable type

3P, Type A and Type D, 3200A to 4000A
3P, Type H, 800A to 4000A

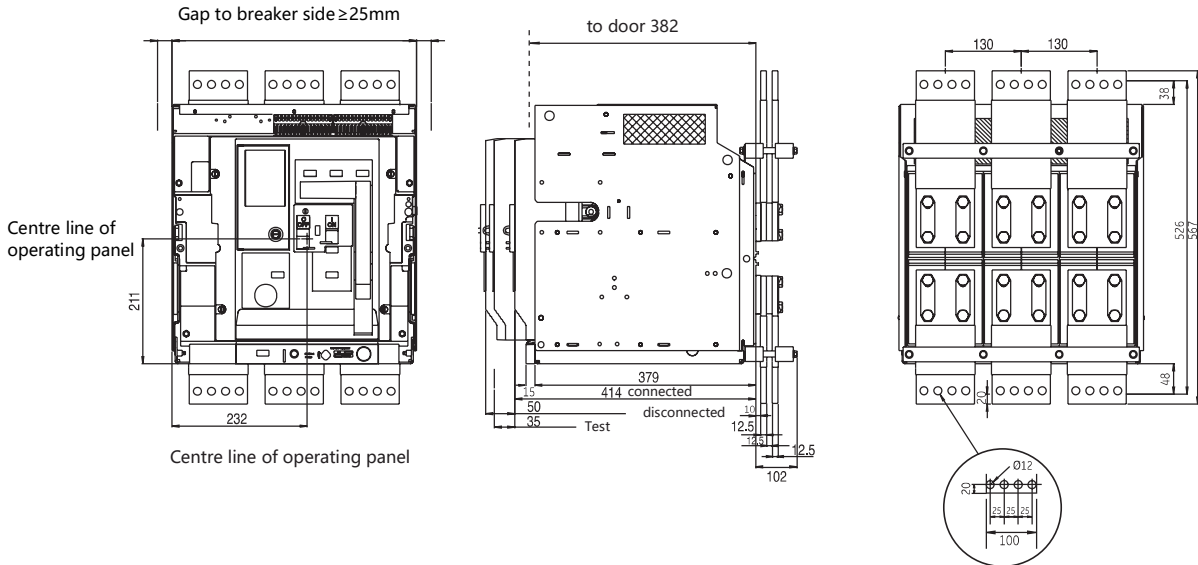

Copperwork must be supported within 200 mm of breaker connections-busbars or cables. All connections to be tightened to 50Nm.

3P, Type A and Type D, 3200A to 4000A
3P, Type H, 800A to 4000A

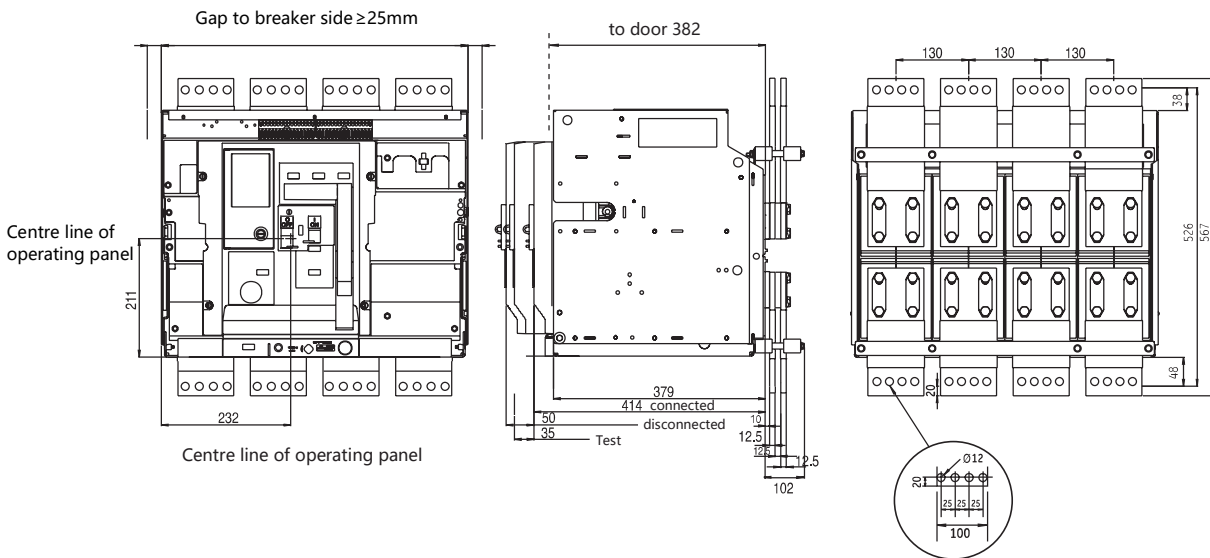

Copperwork must be supported within 200 mm of breaker connections-busbars or cables. All connections to be tightened to 50Nm.

A

B

C

Adaptor connections

Dimensional drawings

Rear Adapter Vertical Connection

Frame 1, Type A, L-Vertical, In=400-1600A

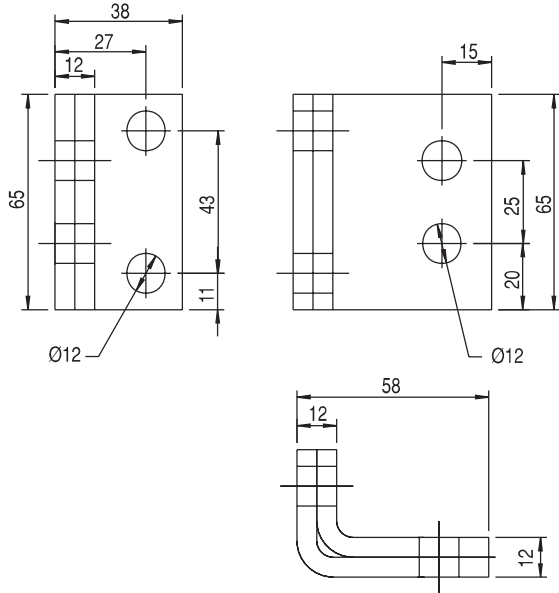

Rear Adapter Horizontal Connection

Frame 1, Type A, L-Horizontal, In=400-1600A

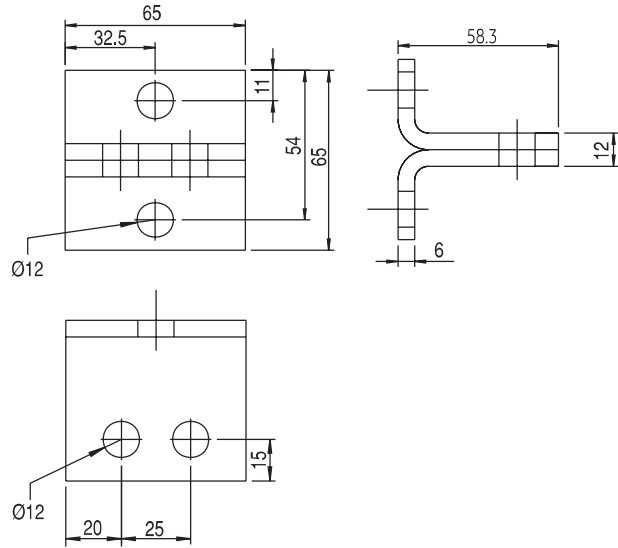

Rear Adapter Vertical / Horizontal Connection

Frame 1, Type D and Type D2, T-shaped, In=400-2500A

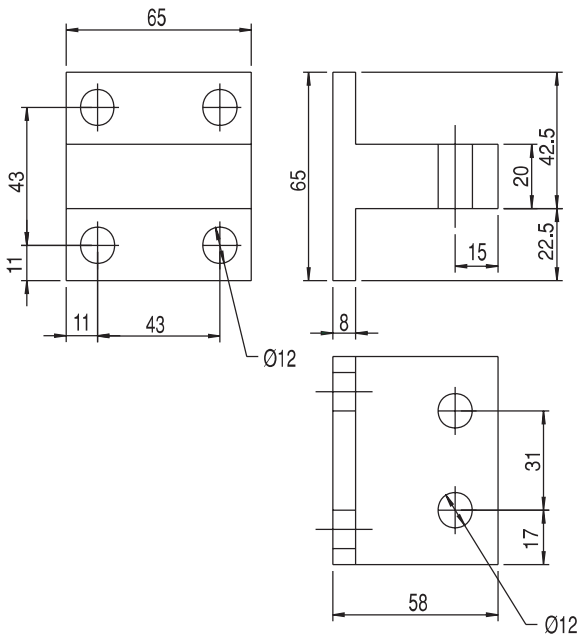

Frame 2, Type A, D, H,T-shaped, In=800-3200

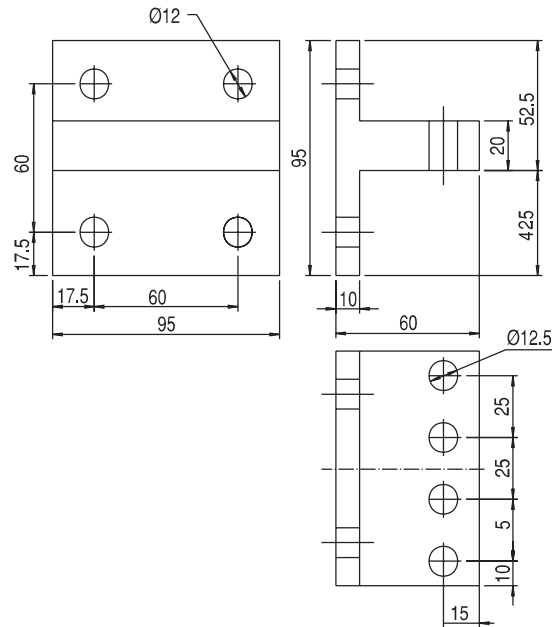

Copper connections - Front access (Fixed and/or withdrawable)

Type A, In=400A to 2500A
 Type D, In=400A to 2500A

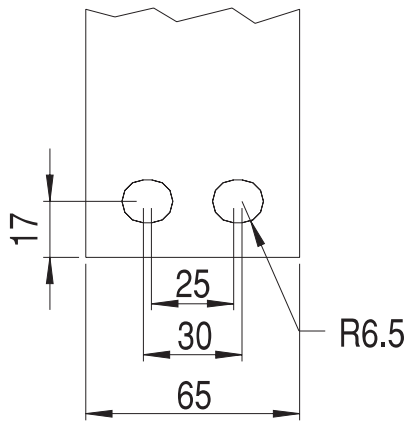

Type A, D, In = 3200A to 4000A
 Type H, In = 800A to 4000A

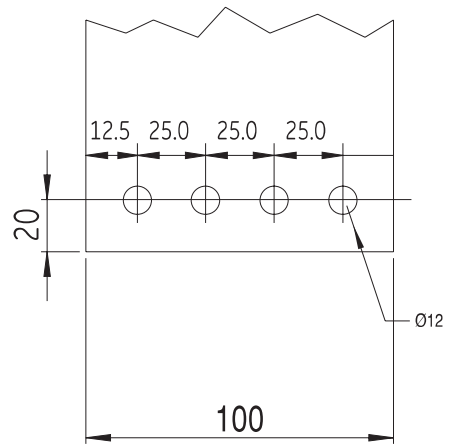

Copper connections - Rear access (withdrawable)

Type A, D, H, In= 4000A

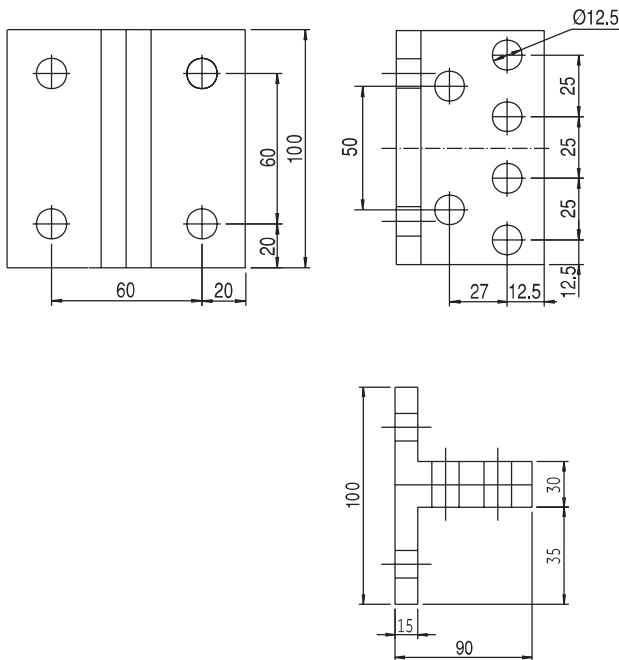

IP54 Door
 (Withdrawable unit only - Frame 1&2 only)

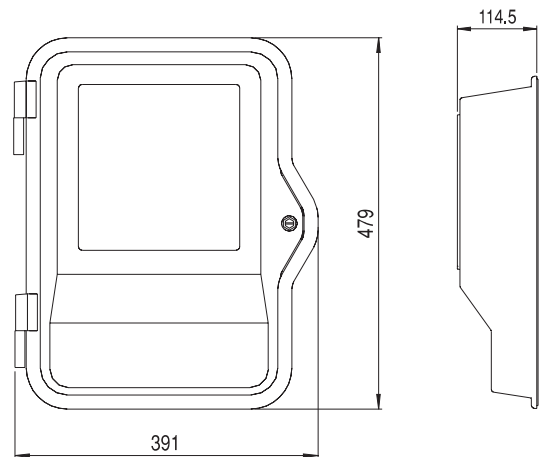

Cassette mounting details (Top view)

Type A, D, D2, In=400A to 2500A

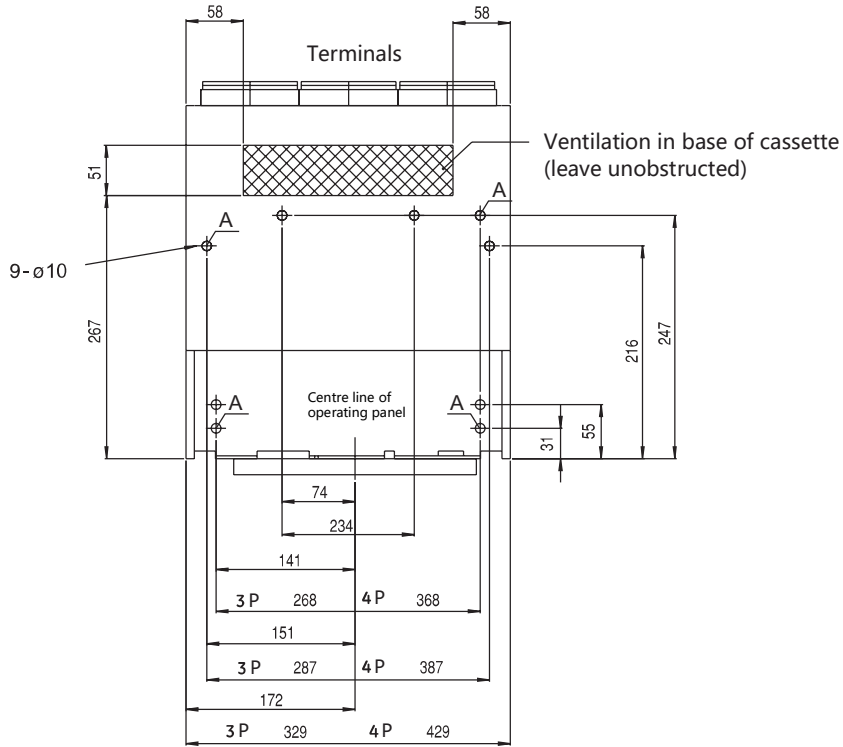

Type A, D, In = 3200A to 4000A
Type H, In = 800A to 4000A

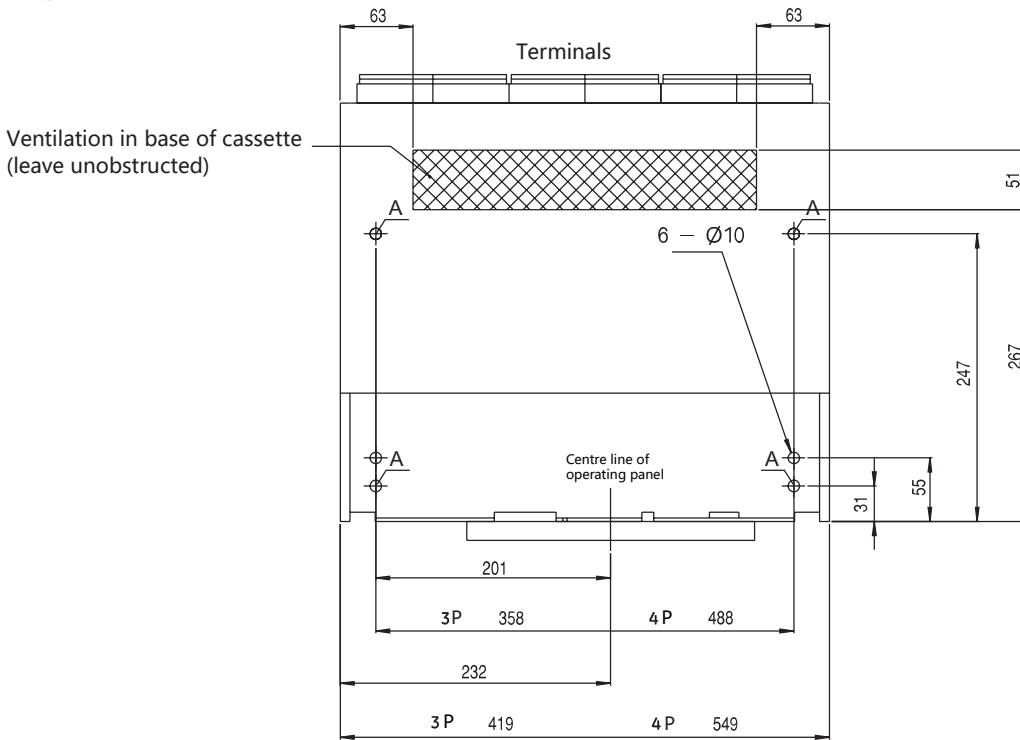

A = recommended installation mounting cut

Door cut-outs

Fixed

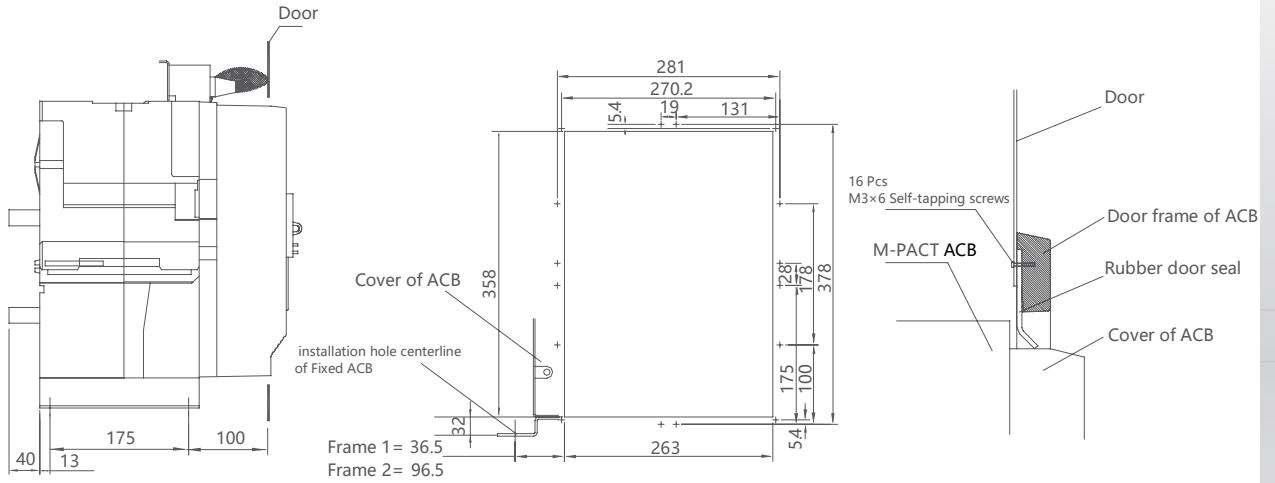

Withdrawable

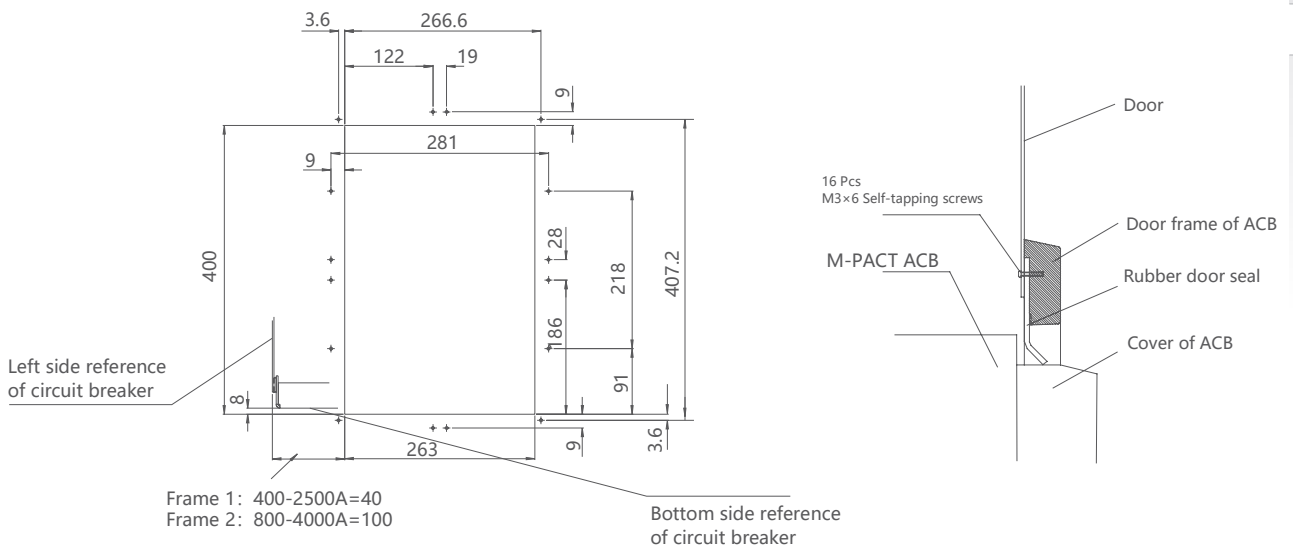

A

B

C

■ Frame 1, External RC coil

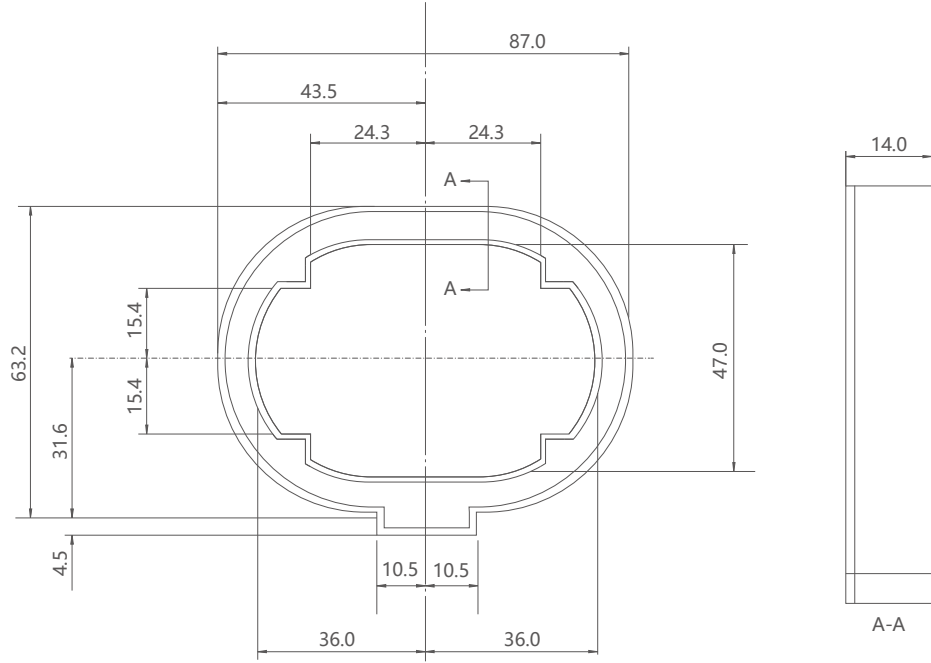

■ Frame 2, External RC coil

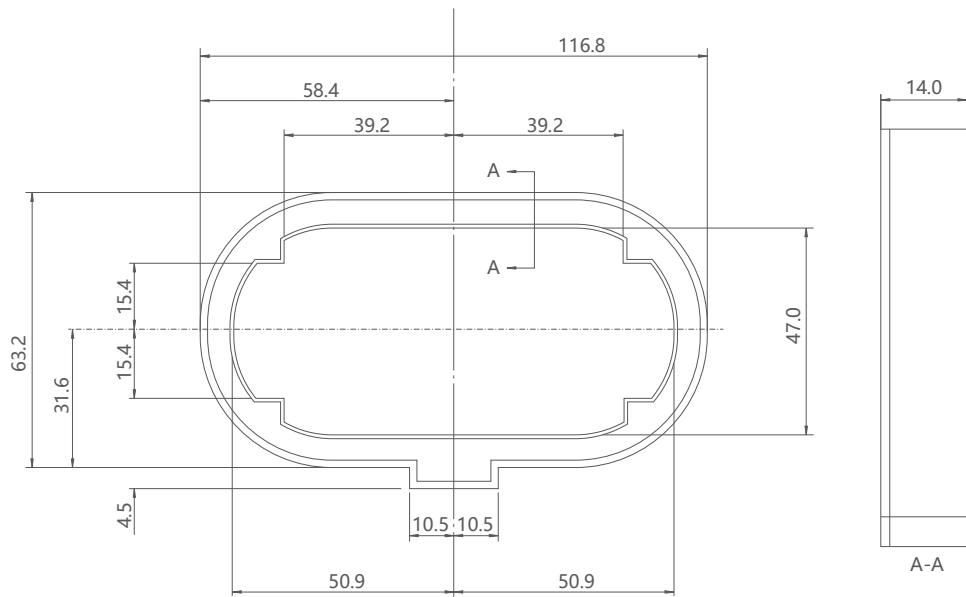

M-PACT, 5000-6400A, Fixed

A

B

C

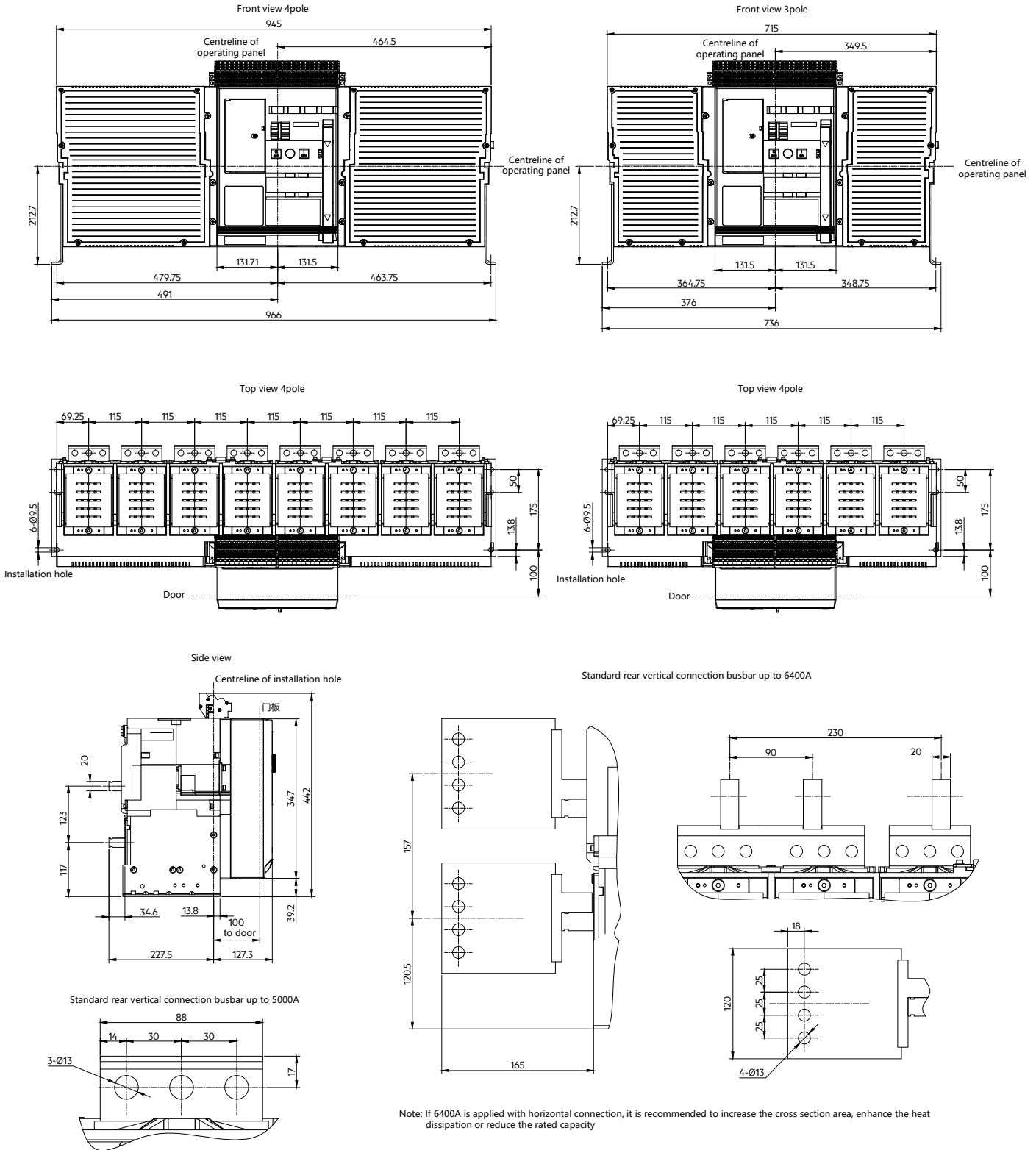

M-PACT, 5000-6400A, Withdrawable

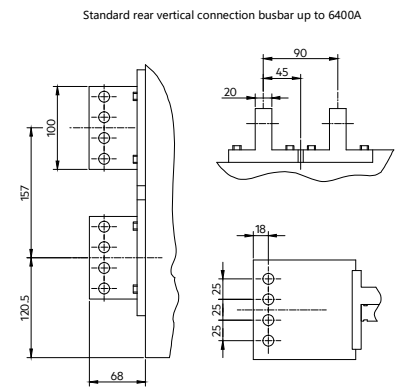
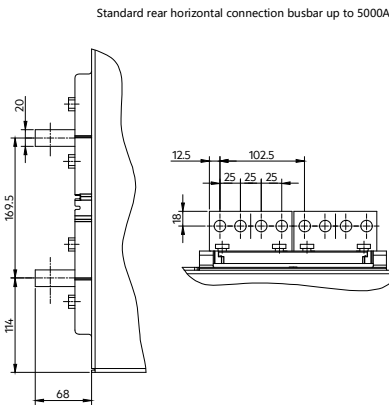
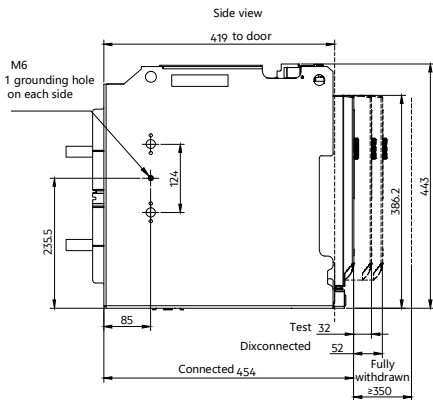
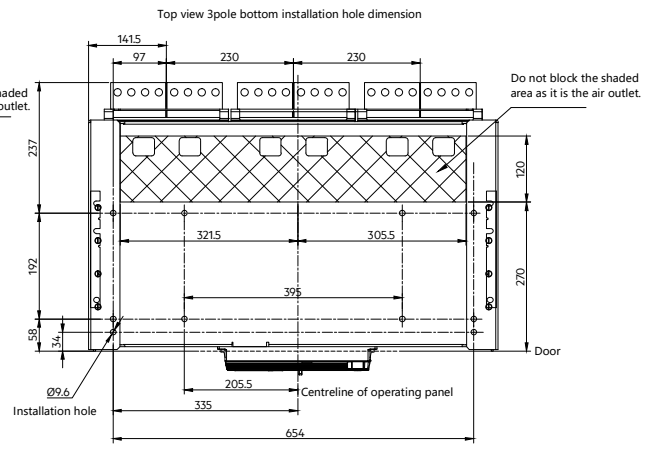
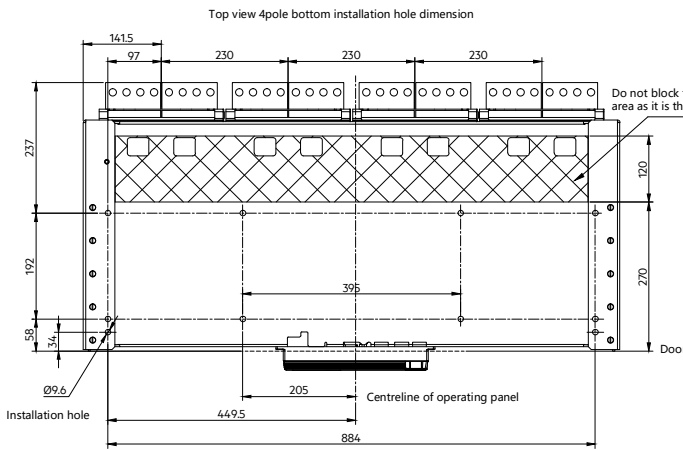
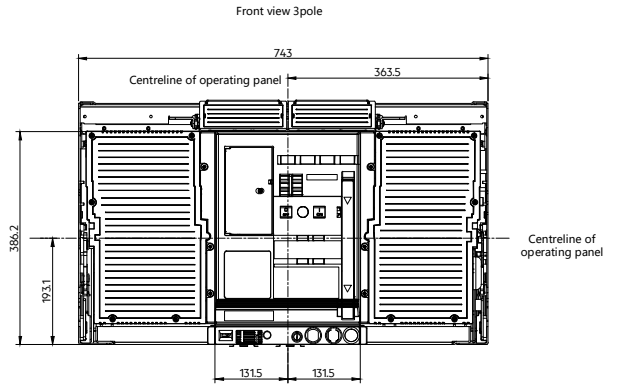
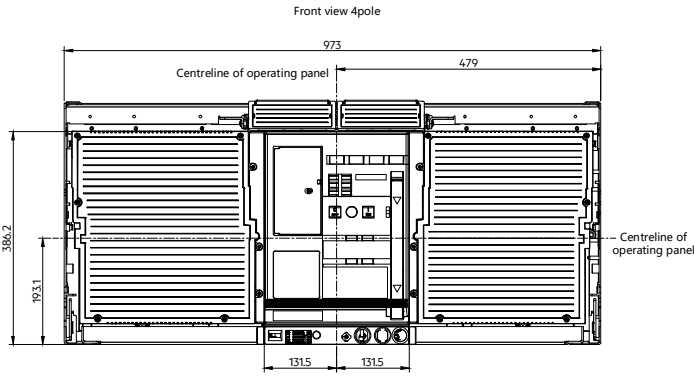

Note: If 6400A is applied with horizontal connection, it is recommended to increase the cross section area, enhance the heat dissipation or reduce the rated capacity

M-PACT, 5000-6400A, Door cut-out dimension

Fixed pattern door cut-out dimension

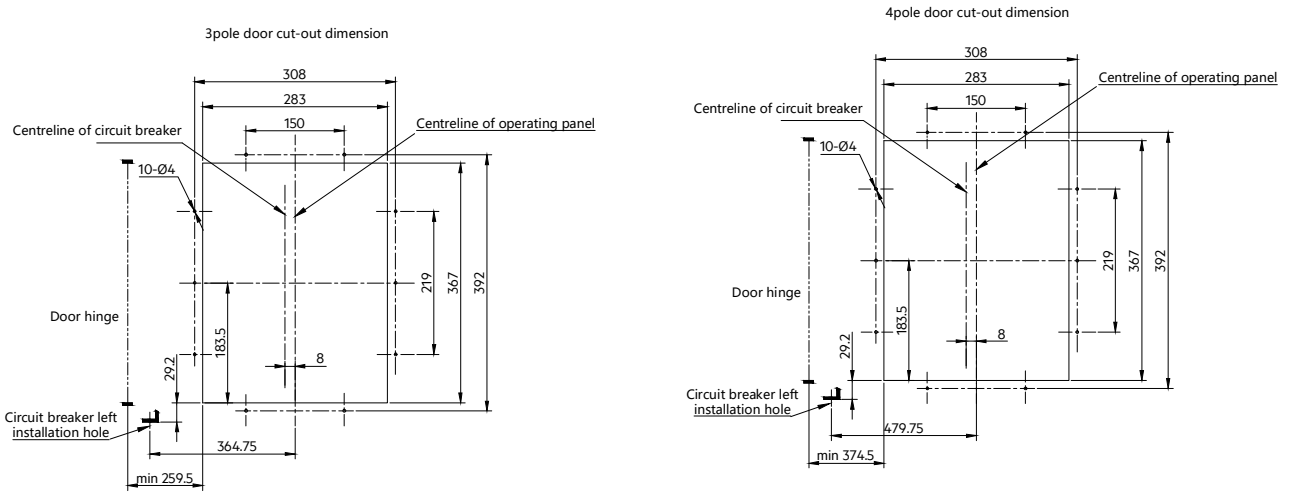

Draw-out pattern door cut-out dimension

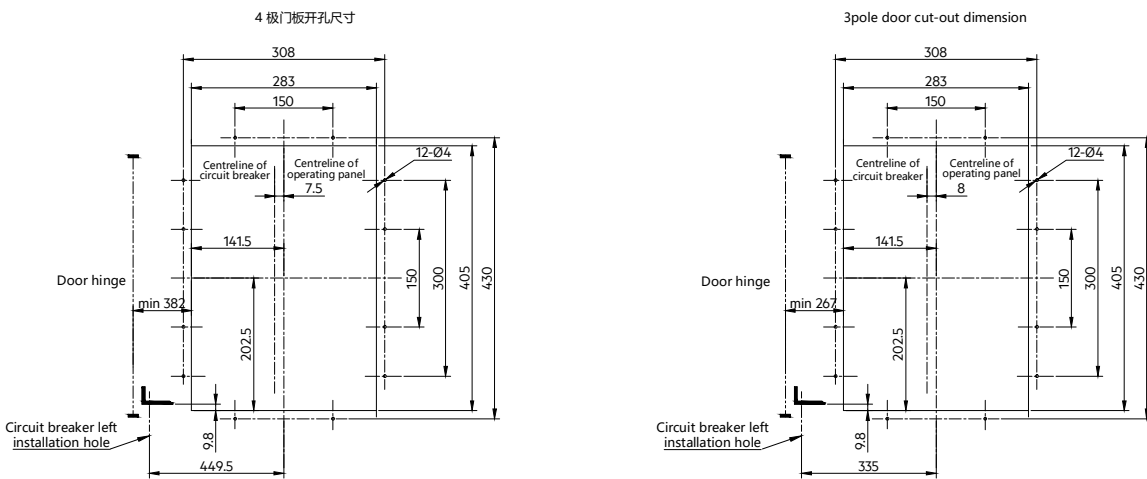

2-Way cable interlocking, 400-4000A

Fixed

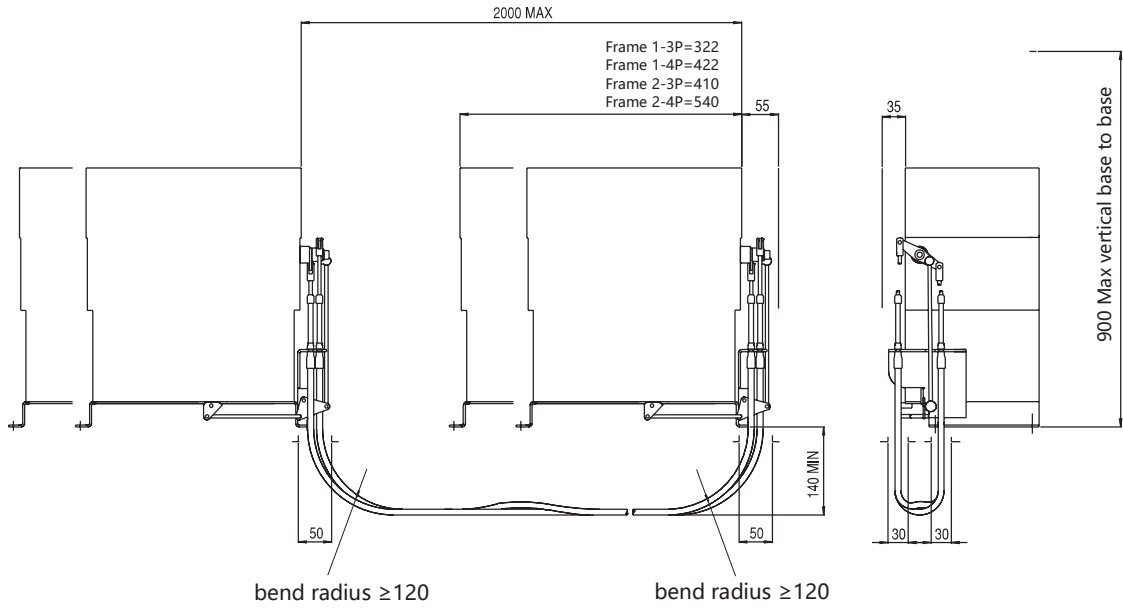

Withdrawable

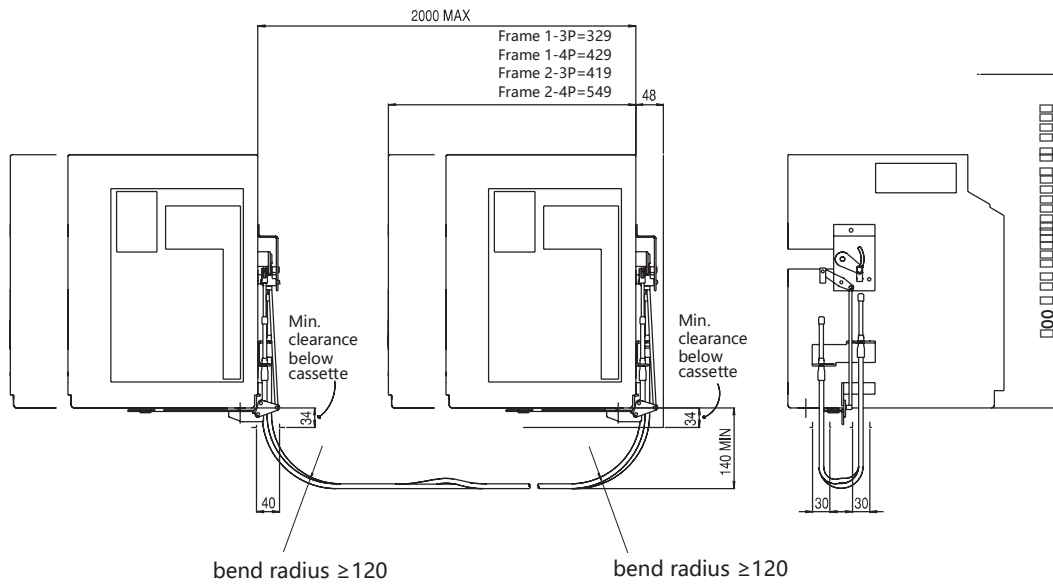

3-Way cable interlocking, 400-4000A

Fixed

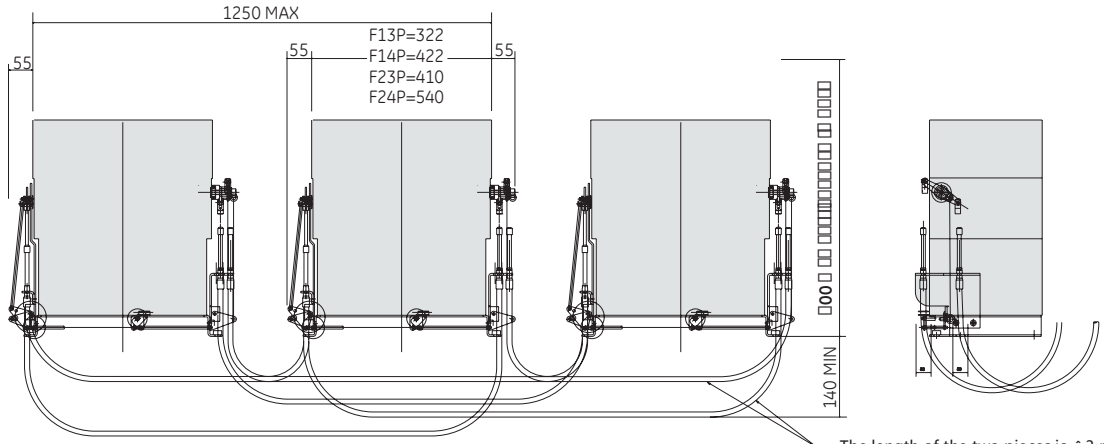

Withdrawable

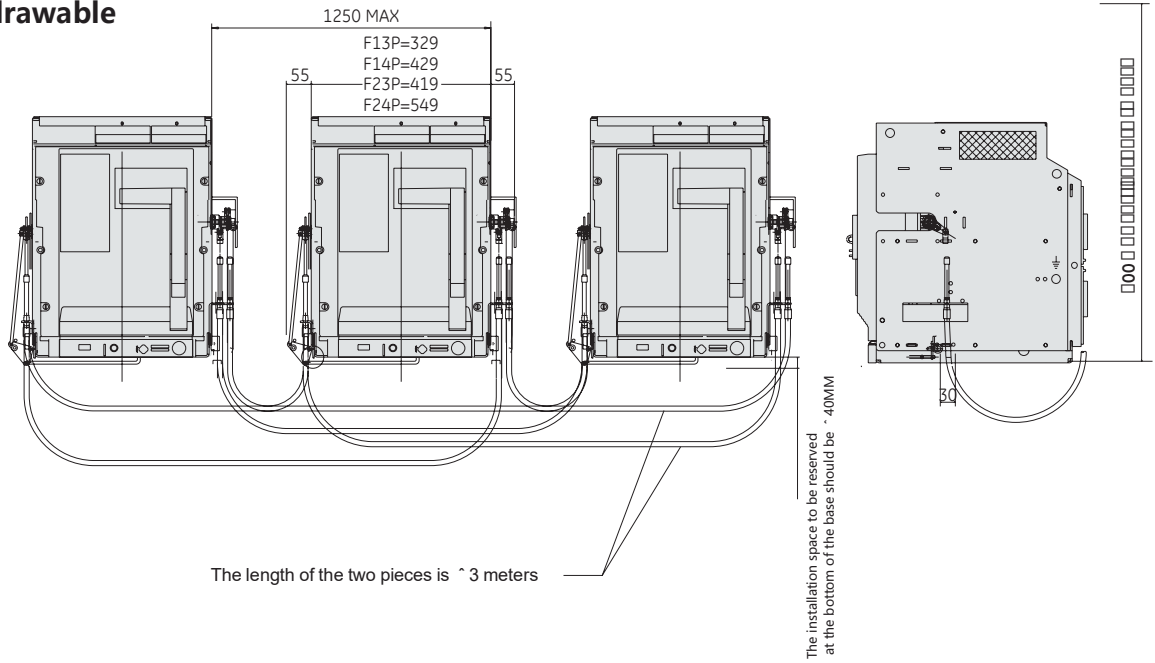

2-Way Mechanical Interlocking Mechanism, 5000-6400A

2-way mechanical interlocking mechanism / Fixed pattern - Front connection / Rear connection

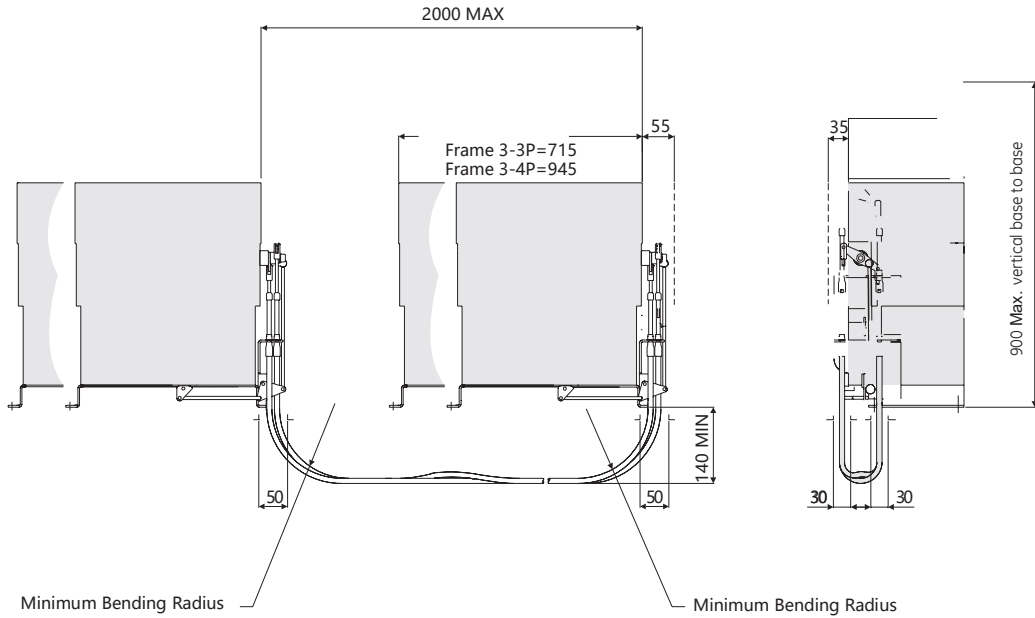

2-way mechanical interlocking mechanism / Draw-out pattern - Front connection / Rear connection

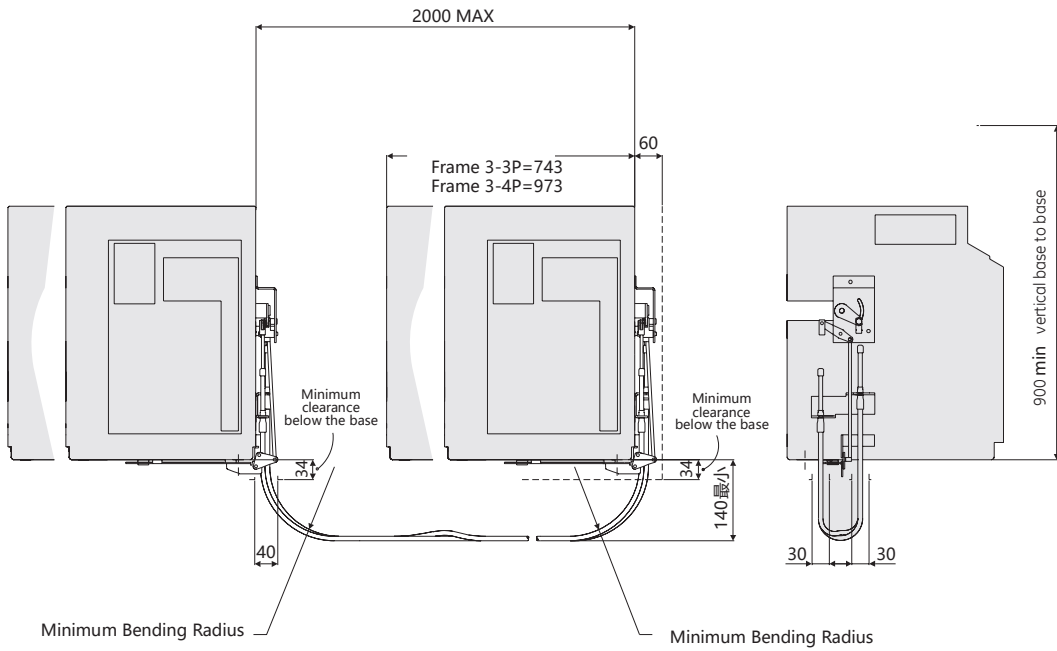

3-Way Mechanical Interlocking Mechanism, 5000-6400A

3-way mechanical interlocking mechanism / Fixed pattern - Front connection / Rear connection

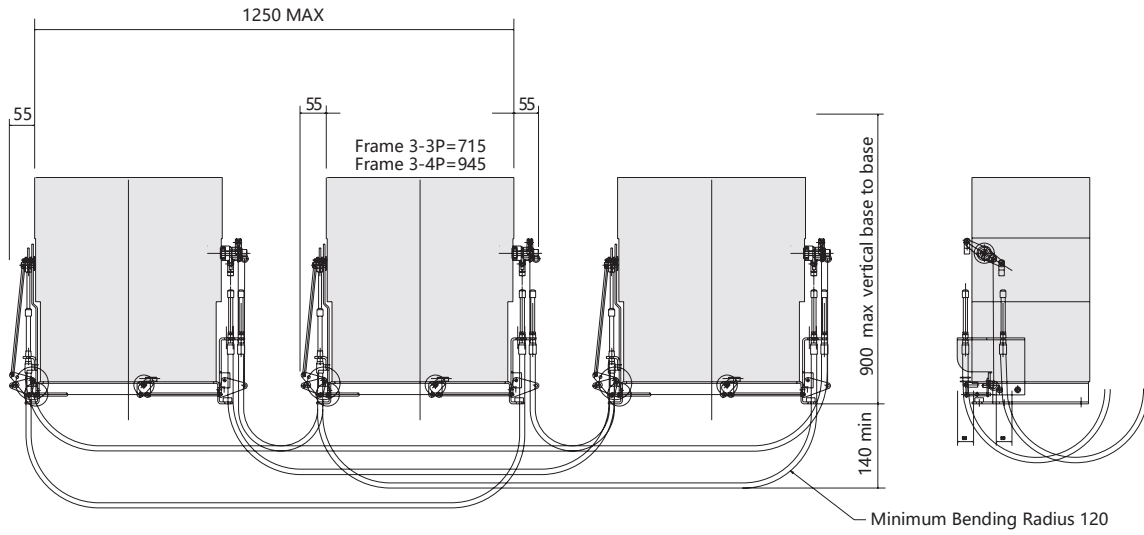

3-way mechanical interlocking mechanism / draw-out pattern - Front connection / Rear connection

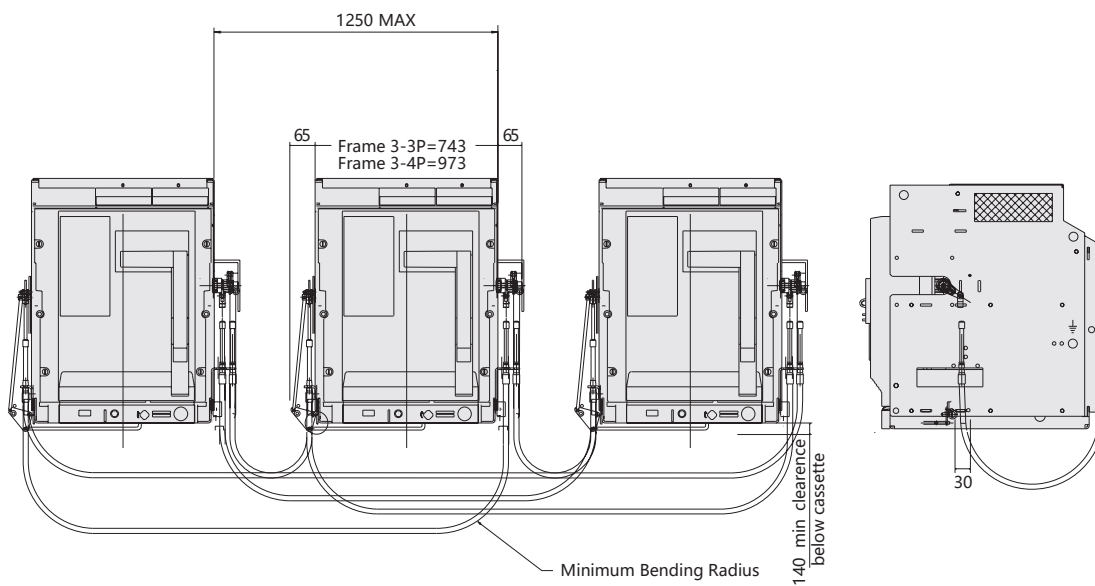

M-PACT air circuit breaker

Frame 0, 400-1600A

Compact air circuit breaker

D.2	Product
D.3	Quick Model Selection
D.5	Technical data
D.6	Control unit
D.8	Accessories
D.10	Application guide
D.13	Dimensional drawings
D.16	Wiring Diagrams
D.17	Order codes

Product

MPACT series compact air circuit breakers, with a frame current rating of 1600A, offer 3 pole and 4 pole products:

- Rated current: 400-1600A
- Rated voltage: AC415V
- Ultimate short-circuit breaking capacity I_{cu}: 65kA

The MPACT compact air circuit breaker provides a standard Mpro intelligent control unit, equipped with LSI protection and optional grounding protection function. The control unit adopts a LCD display screen, which can quickly set circuit breaker protection parameters and check the operation and maintenance status of the circuit breaker.

Leading customer needs



Minimalist specifications, efficient design, and fast selection

400-1600A, one kind of breaking capacity
Standard configuration covers the vast majority of applications



Global design, meeting IEC and GB standards

Widely used in power distribution and control systems IEC60947-2, GB/T 14048.2



Small volume with high breaking protection

Compact and scientific design
Provide cost-effective products to reduce space usage



Inheriting the lean manufacturing of AEG air circuit breakers

ALPS Lean Manufacturing System

Control

High reliability operation, worry free safety

Quick model selection

MP	N		3		0		W		10		Mpro2M
Product series	Breaking capacity		Poles		Frame		Installations		Rated current		Control unit
M-PACT Air circuit breaker	N	Icu	65kA		3	3P	0	Frame 0	W	Withdrawable	Mpro2M
		Ics	55kA		4	4P	F	Fixed	F	Fixed	
		Icw	50kA								
		04	400A						06	630A	
		08	800A						10	1000A	
		12	1250A						16	1600A	

Mpro Control unit

Basic type	Model code	Function description
Mpro control unit	2M	Standard configuration: LSI protection, current measurement, LCD display
Optional features	MPN0UEF	Ground protection of vector sum
	MPN0NP	Neutral phase protection
	MPN0OPL	Opening position lock
	MPN0WPFA	Drawer position contact

Selection Example

Requirement: Rated current 1000A, 3P, withdrawable type, ultimate short-circuit breaking capacity 65kA, LSI protection, current measurement.

Model: MPN30W10Mpro2M

Withdrawable circuit breaker - quick selection

Breaking code	Frame	Rated current	Withdrawable 3-pole	Withdrawable 4-pole		Mpro2M
N AC 415V Icu=65kA Ics=55kA Icw=50kA	0	400	MPN30W04	MPN40W04	+	Mpro2M
		630	MPN30W06	MPN40W06		
		800	MPN30W08	MPN40W08		
		1000	MPN30W10	MPN40W10		
		1250	MPN30W12	MPN40W12		
		1600	MPN30W16	MPN40W16		

Fixed circuit breaker - quick selection

Breaking code	Frame	Rated current	Fixed 3-pole	Fixed 4-pole		Mpro2M
N AC 415V Icu=65kA Ics=55kA Icw=50kA	0	400	MPN30F04	MPN40F04	+	Mpro2M
		630	MPN30F06	MPN40F06		
		800	MPN30F08	MPN40F08		
		1000	MPN30F10	MPN40F10		
		1250	MPN30F12	MPN40F12		
		1600	MPN30F16	MPN40F16		

Technical data of MPACT compact air circuit breaker			
Breaking capacity code			N
Rated current	In	A	400-1600
Number of poles			3P, 4P
Rated insulation voltage	Ui	V	1000
Rated impulse withstand voltage	Uimp	kV	12
Rated working voltage	Ue	V	AC415
Usage category			B
Isolation function			Yes
Rated current of neutral pole			100%Phase line
Breaking parameters			
Rated ultimate short-circuit breaking capacity Icu	AC415V	kA	65
Rated short-circuit breaking capacity Ics	AC415V	kA	55
Rated short-circuit withstand current Icw (1s)	AC415V	kA	50
Rated short-circuit making capacity Icm	AC415V	kA	143
Mpro control unit			
	MPro2M	L	■
		S	■
		I	■
		G	□
Operational performance			
Mechanical life	With maintenance	time	20000
	No maintenance	time	10000
Electrical life, AC415V, no maintenance		time	6000
Full opening time		ms	≤30
Closing time		ms	≤70
Installations			
Fixed			
	Height	mm	322
	Width 3P	mm	281
	Width 4P	mm	351
	Depth	mm	237
Available connection methods	Horizontal rear connection		■
Weight	3P	kg	25
	4P	kg	32
Withdrawable			
	Height	mm	354
	Width 3P	mm	308
	Width 4P	mm	378
	Depth	mm	339
Available connection methods	Horizontal rear connection		■
Weight	3P	kg	40
	4P	kg	50

Note: ■Standard configuration, □Optional configuration;

Mpro2M intelligent control unit		Mpro2M
Protection function	Overload long time protection	●
	Short circuit short delay (time limit) protection	●
	Short circuit short delay (inverse time) protection	●
	Short circuit instantaneous protection	●
	Thermal memory	●
	Grounding protection	○
	MCR (making and breaking current)	●
	HSISC (trip beyond limit)	●
	Current imbalance protection	●
	Neutral line protection	○
Measurement function	Current measurement	●
Maintenance functions	Tripping test	●
	Self diagnostic function	●
	Lock function	●
	Number of operations	●
	Tripping record (8 times)	●
	Alarm records (8 times)	●
External power supply	AC220V	○
	AC380V	○
	DC24V	○

Mpro Intelligent control unit, protection features

Mpro2M

Overload long time protection							
Current setting range	Ir	0.4-1xIn, OFF, set step size 1A					
Long time protection characteristics							
	Current, I/Ir	Tripping time					
Inaction characteristic	<1.05	Inaction					
Action characteristics	≥1.2	Action within 2 hours					
	Tr (s)	15	30	60	120	240	480
Inverse time delay time T (s), ≤	1.5Ir	15	30	60	120	240	480
	2.0Ir	8.4	16.9	33.7	67.5	135	270
$T = \frac{(1.5Ir)^2}{I^2} tr$	7.2Ir	0.65	1.3	2.6	5.2	10.4	20.8
	Accuracy	± 10% (fixed absolute error ± 40ms)					
Thermal memory	Release within 30 minutes, can be cleared after power failure						
Short circuit short delay protection							
Setting range	Isd	1.5-15Ir, OFF					
Time setting	Timed delay	0.1-0.4s (0.1 level difference), OFF, accuracy ± 10%					
	Inverse time delay	Curve same as overload long time					
	Inverse time thermal memory	Release within 15 minutes, can be cleared after power outage. If you need to open the thermal memory, please indicate it when placing an order					
Short circuit instantaneous protection							
Setting range	Ii	1-20In, OFF; accuracy ± 15%					
Grounding protection (optional)							
Setting range	Ig	0.2-1In, OFF (minimum 160A)					
	Action characteristics	≤ 0.8Ig, no action; > 1.0Ig, action; Accuracy ± 10%					
Time setting	tg	0.1-0.4s, OFF (0.1s level difference), accuracy ± 10%					
	Inverse time shear coefficient	1.5-6, OFF (level difference of 0.5)					
Current imbalance							
Description	$I_{avg} = (I_a + I_b + I_c) / 3$; $I_{unbal} = E_{max} / I_{avg} * 100\%$						
Start value	5% -60%, level difference of 1%						
Delay Time	0.1-120s, level difference of 0.1s						
Return value	5% - Start value, level difference of 1%						
Return time	10-200s, level difference of 1s						
MCR (making and breaking current) and HSISC (trip over limit) protection							
Setting current	30-100kA, set step size 1kA, <40ms						

Auxiliary contact

Auxiliary contacts are used to indicate the open or closed position of the circuit breaker. The standard configuration is 4NO+4NC.

Technical parameter		
I _{th}	6A	
Breaking capacity	DC-13	0.3A, DC250V
	AC-15	1A, AC400V

Opening coil

It can be operated remotely to open the circuit breaker. Shunt release devices are available in both instantaneous and long time power on type.

Technical parameter	
Rated control voltage U _s (V)	AC230, AC400 DC110/220
Action voltage (V)	0.7-1.1 U _s
Closing time	≤40ms

Motor operating mechanism

The motor operating mechanism is driven by an external power source to store energy in the circuit breaker mechanism. Once the energy is stored, the motor will automatically turn off the power and stop running; The electric motor operating mechanism can achieve automatic pre energy storage.

Technical parameter	
Rated control voltage U _s (V) AC230, AC400, DC220	
Operating voltage (V)	0.8-1.1 U _s

Power

Accessories type			AC230V	AC400V	DC220V
Closing coil	Closing power	VA/W	295	360	295
	Opening power	VA/W	295	360	295
Undervoltage coil	Power loss	VA	24	36	
Motor operating mechanism	Output power	VA/W	50	50	50

Closing coil

After the electric energy storage is completed, Closed electromagnetic coil releases the energy storage spring force of the operating mechanism instantly, causing the circuit breaker to quickly close.

Technical parameter	
Rated control voltage U _s (V)	AC230, AC400 DC110/220
Action voltage (V)	0.85-1.1 U _s
Closing time	≤60ms

Undervoltage coil

When the power supply voltage is lower than the rated value, the undervoltage release can quickly open the circuit breaker. Release method: instantaneous release, delayed release
Delay tripping time: 1-5s adjustable

Technical parameter	
Rated control voltage U _s (V)	AC230, AC400
Action voltage (V)	0.35-0.7 U _e
Reliable closing voltage (V)	0.85-1.1 U _e
Reliable non closing voltage (V)	≤0.35U _e

Phase separator

The phase separator is made of insulating material and installed vertically between the connecting bars of the fixed part of the circuit breaker. Prevent arc from spreading inside the circuit breaker.

Power conversion module

The power conversion module is used to convert external auxiliary power to DC 24V. Normally, external power can be directly connected to terminals 1 and 2 without the need for a power conversion module. The type and voltage level of external power connection must be consistent with the ordering specifications.

Position switch

The cassette of the MPACT series compact air circuit breaker provides mechanical indication of the body's "connection/test/separation" position, and the optional three position electrical contacts can also indicate that the body is in the "connection/test/separation" position.

Running position switch: a switching switch that only operates when it reaches the connection between the main circuit and the control circuit.

Test position switch: a switching switch that only operates when the main circuit is isolated, the safety barrier is closed, and the control circuit is connected.

Separation position switch: a switching switch that only operates when the main circuit and control circuit are isolated.

Door frame

Installed on the cabinet door, with a protection level of IP40.

Opening position lock

The opening position lock can lock the opening button of the circuit breaker in the pressed position, and the circuit breaker cannot be closed at this time.

Specification parameter table for copper busbar of circuit breaker main circuit connection

Rated current		Copper bar specifications	
Inm (A)	Numbers	Size	
400	1	50*5	
630	2	50*5	
800	2	50*5	
1000	3	50*5	
1250	4	50*5	
1600	4	50*5	

Connection form

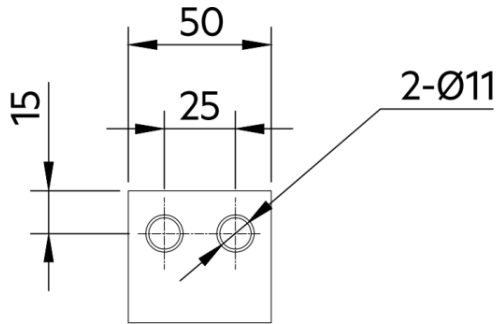

Tightening torque		
Diameter	Spring washer or flat washer	Contact washer or corrugated washer
Ø11mm	50Nm	75Nm

- 1- Circuit breaker terminals
- 2- Busbar
- 3-Bolt
- 4- Waher
- 5-Nut

Power loss, ambient temperature+40 ° C

Frame current	Power loss (W)	
Inm (A)	Fixed type	Withdrawable type
M-PACT, frame 0	≤130	≤345

Note: Power loss is measured at the frame rated current Inm of the circuit breaker

Temperature derating factor

Rated current In (A)	Ambient temperature				
	40°C	45°C	50°C	55°C	60°C
400	1	1	1	1	1
630	1	1	1	1	1
800	1	1	1	1	1
1000	1	1	0.95	0.89	0.85
1250	1	1	1	0.95	0.89
1600	1	0.95	0.89	0.85	0.78

High altitude capacity derating

	Altitude			
	5000	4000	3000	2000
Power frequency withstand voltage (V)	2200	2500	3150	3500
Short circuit breaking capacity correction factor	0.8	0.85	0.89	1
Rated current correction factor	0.8	0.85	0.89	1

Secondary wiring

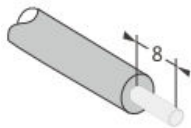

0.5mm² ≤ cross-sectional area ≤ 4mm²

Safe distance of circuit breaker

Product type	To insulator		To metal	
	A	B	A	B
Withdrawable	0	0	0	0
Fixed	0	30	0	70

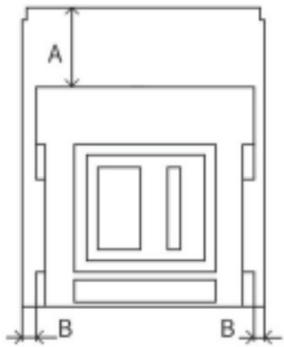

Withdrawable circuit breaker

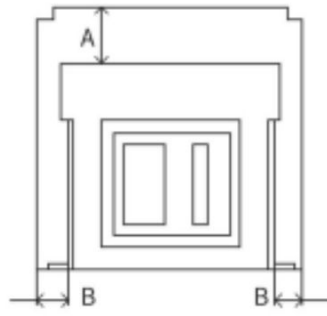

Fixed circuit breaker

Factory default settings for protection parameters

Parameter type		
Overload long time, current	I_r	$1 \cdot I_n$
Overload long time, time	T_r	120s
Short circuit short delay, current	I_{sd}	$1.5 \cdot I_r$
Short circuit short delay, time	T_{sd}	0.2s
Short circuit instantaneous, current	I_i	$2 \cdot I_n$
Ground fault, current	I_g	OFF
Ground fault, time	T_g	OFF

M-PACT frame 0, Withdrawable

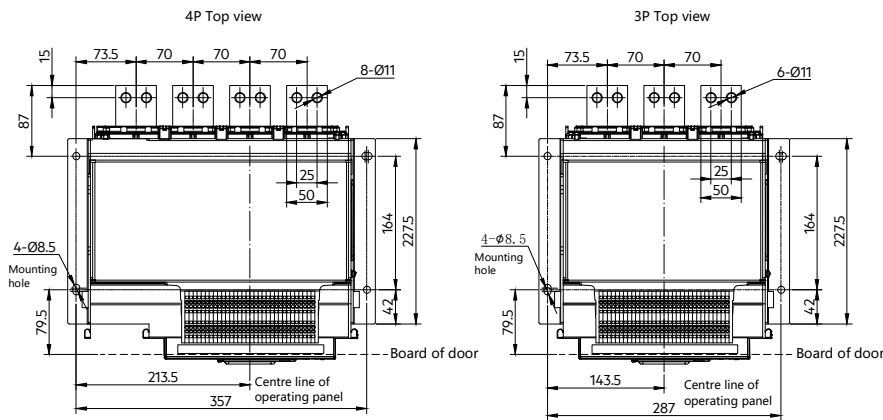
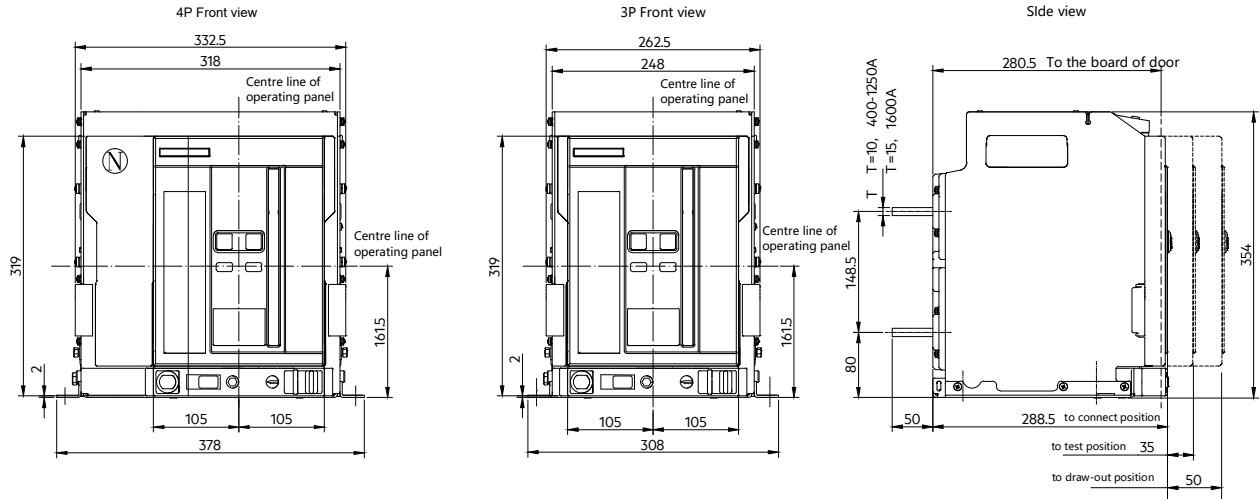

Phase separator

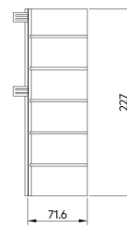

Door cut-outs

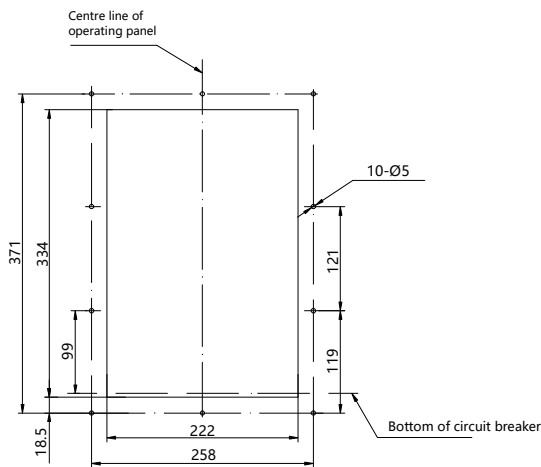

MPACT frame 0, Fixed style

4P Front view

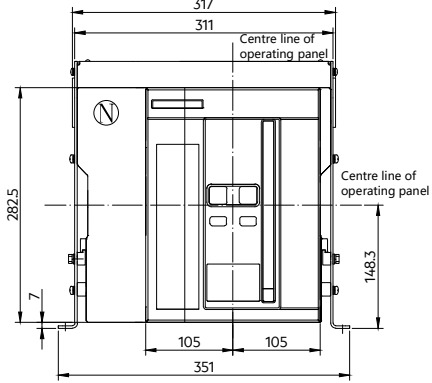

3P Front view

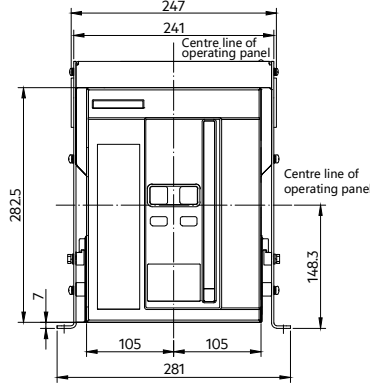

Side view

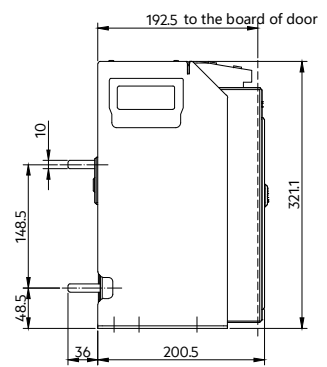

4P Top view

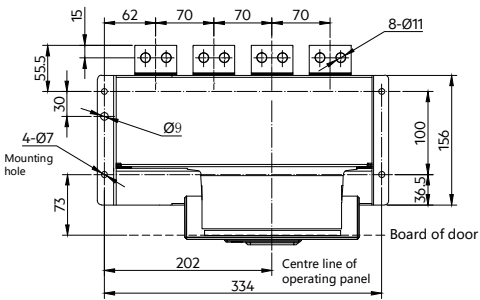

3P Top view

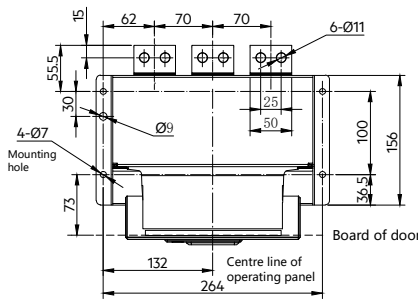

Phase separator

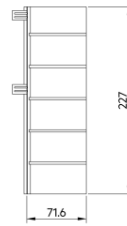

Door cut-outs

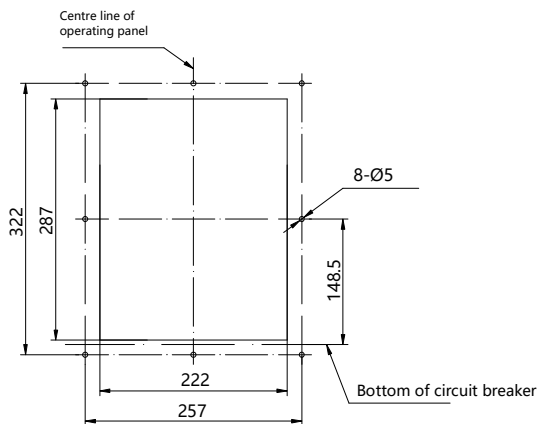

External accessories

Power module, undervoltage delay module, installed on withdrawable circuit breaker

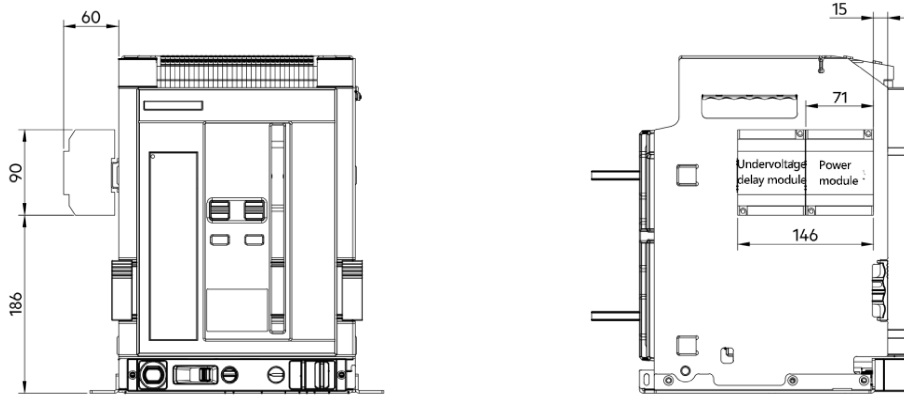

Power module, undervoltage delay module, installed on fixed circuit breaker

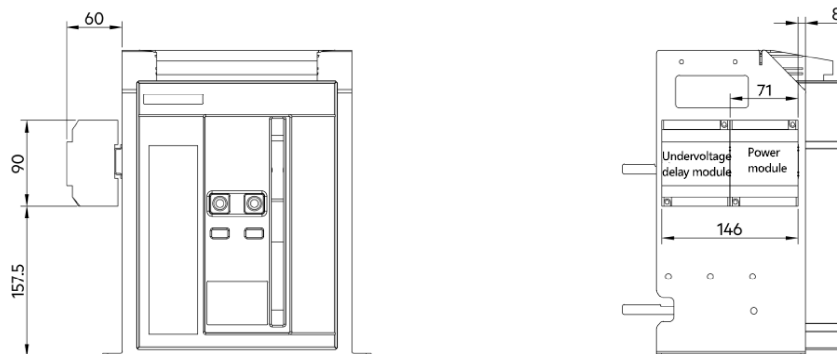

Note: When selecting a voltage of non AC230V or DC24V for the controller, the external power supply needs to be converted to DC24V through the power module (included in the factory) and then connected to terminals 1 and 2 of the circuit breaker.

3P circuit breaker, external transformer for N-pole protection, ground protection of vector sum

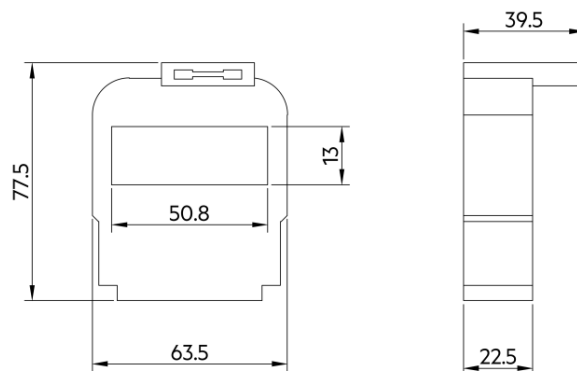

Mpro2M Wiring Diagrams of intelligent control unit

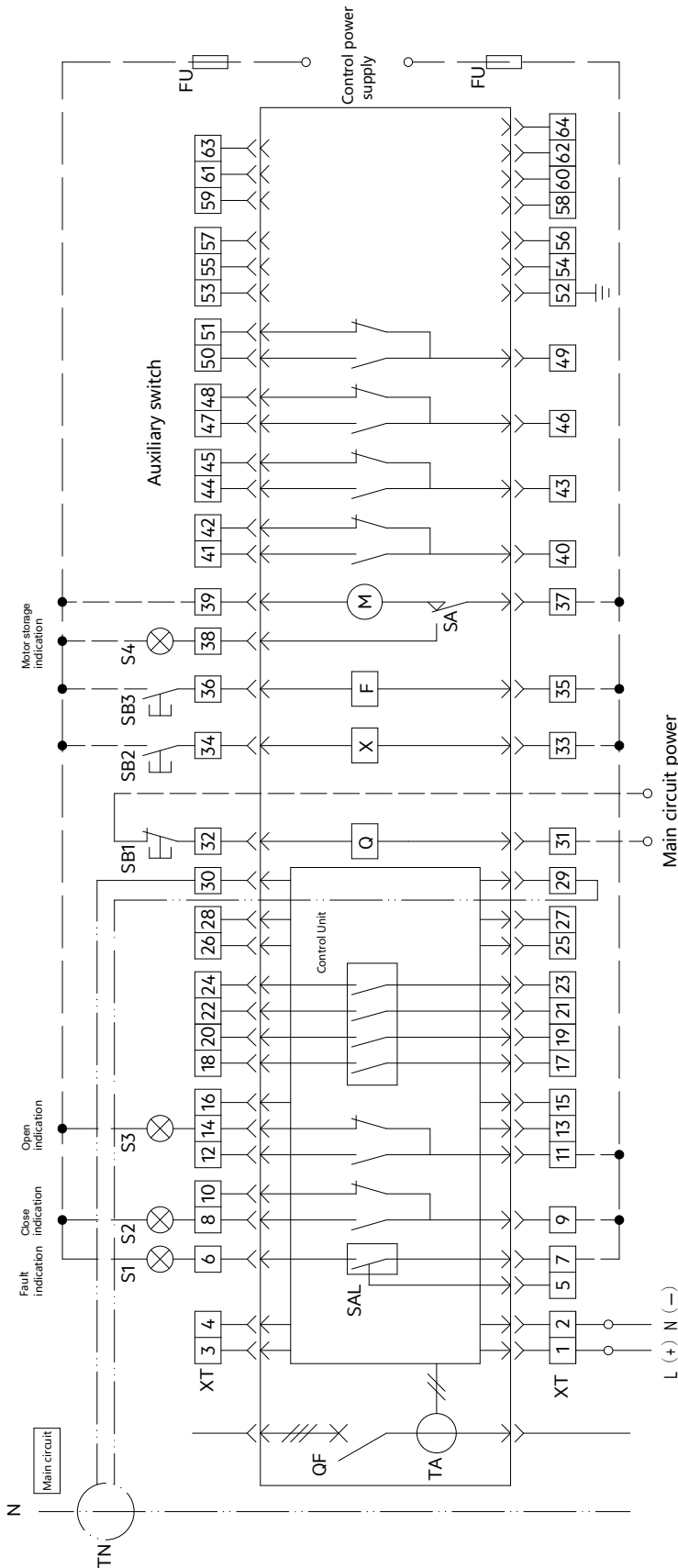

Note: The external power supply can be directly connected to terminals 1 and 2, and the type and voltage level of the external power supply must be consistent with the ordering specifications.

Control unit terminal function:

Terminal number	Terminal function	Terminal number	Terminal function
1 2	Control unit working power input terminal. 1 is L (+), 2 is N (-)	19 20	vacancy
3 4	vacancy	21 22	vacancy
5 6 7	output for fault tripping	23 24	vacancy
8 9 10	output for auxiliary switch	25 26 27 28	vacancy
11 12 14	vacancy	29 30	External N-phase transformer input terminal, when 3P+N (optional function)
17 18	vacancy	52	protection grounding wire of control unit

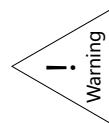

The control unit must be connected to the working power supply to ensure the normal operation of the circuit breaker!

Code and description

Code	Description	Code	Description	Code	Description
X	Closing coil	QF	Circuit breaker	SB2	Closing button (user provided)
F	Shunt trip	S1~S4	Indicator light (user provided)	SB3	Opening button (user provided)
FU	Fuse (user provided)	SA	Signal switch of motor	TA	Current Transformer
M	Motor Operator	SAL	Alarm contact for Fault tripping	TN	External N-phase transformer
Q	Undervoltage release	SB1	Undervoltage button (user provided)	XT	Control circuit wiring terminal

Control circuit wiring instructions:

1. If the control voltages of X, F, and M are different, it should be connected to different power sources separately.
2. Terminal 39 can be directly connected to the power supply (automatic pre energy storage), or connected in series with a normally open button and then connected to the power supply (manual pre energy storage).

1.PO No.:	2.Delivery date:	3.Brand:	4.Switchgear manufacturer:
5.Customer name:	6.Project name:	7.Industry:	8.Quantity: _____ Pcs
Specify on the order			
Code	MP <input type="checkbox"/> <input type="checkbox"/> <input type="checkbox"/> <input type="checkbox"/> <input type="checkbox"/> <input type="checkbox"/> <input type="checkbox"/> <input type="checkbox"/> <input type="checkbox"/> <input type="checkbox"/> <input type="checkbox"/> <input type="checkbox"/> <input type="checkbox"/> <input type="checkbox"/> <input type="checkbox"/> <input type="checkbox"/> <input type="checkbox"/> <input type="checkbox"/> <input type="checkbox"/> <input type="checkbox"/> <input type="checkbox"/> <input type="checkbox"/> <input type="checkbox"/>	Rated voltage Ue <input checked="" type="checkbox"/> AC415V	
1.Breaking capacity <input checked="" type="checkbox"/> Type N, Icu=65kA, Ics=55kA, Icw=50kA			
2.Rating	<input type="checkbox"/> 400A	<input type="checkbox"/> 630A	<input type="checkbox"/> 800A <input type="checkbox"/> 1000A <input type="checkbox"/> 1250A <input type="checkbox"/> 1600A
3.Number of poles	<input type="checkbox"/> 3 poles	<input type="checkbox"/> 4 poles(Left Neutral)	
4.System	<input type="checkbox"/> 3-phase 3-wire	<input type="checkbox"/> 3-phase 4-wire	
5.Frequency	<input type="checkbox"/> 50Hz	<input type="checkbox"/> 60Hz	
6.Installation type	<input type="checkbox"/> Fixed	<input type="checkbox"/> Withdrawable	
7.Busbar type	Top terminal	Bottom terminal	
	<input checked="" type="checkbox"/> Rear horizontal connection	<input checked="" type="checkbox"/> Rear horizontal connection	
8.Control Unit	<input type="checkbox"/> Mpro2M		
Mpro2M Optional Features	<input type="checkbox"/> Grounding protection (vector sum)	<input type="checkbox"/> Neutral phase protection	
9.External power supply for control unit	<input type="checkbox"/> AC230V	<input type="checkbox"/> AC400V	
	<input type="checkbox"/> DC24V	<input type="checkbox"/> DC110V	<input type="checkbox"/> DC220V
10.Auxiliary switch	<input checked="" type="checkbox"/> 4NO+4NC		
11.Control voltage			
Opening coil	<input type="checkbox"/> AC230V	<input type="checkbox"/> AC400V	<input type="checkbox"/> DC220V
Closing coil	<input type="checkbox"/> AC230V	<input type="checkbox"/> AC400V	<input type="checkbox"/> DC220V
Motor operator	<input type="checkbox"/> AC230V	<input type="checkbox"/> AC400V	<input type="checkbox"/> DC220V
Undervoltage release	<input type="checkbox"/> AC230V	<input type="checkbox"/> AC400V	
Undervoltage release Time Delayed	<input type="checkbox"/> AC230V	<input type="checkbox"/> AC400V	
Undervoltage delay type	<input type="checkbox"/> 1-5s adjustable		
12.Trip Alarm contact	<input checked="" type="checkbox"/> 1NO+1NC		
13.Position switch	<input type="checkbox"/> Circuit breaker three position switch		
14.Off position interlock	<input type="checkbox"/> Lock A	<input type="checkbox"/> Lock B	<input type="checkbox"/> Lock C <input type="checkbox"/> Lock D <input type="checkbox"/> Lock E
15.Other Accessory	<input checked="" type="checkbox"/> Door frame		<input checked="" type="checkbox"/> Phase separator
	<input type="checkbox"/> If there are dedicated monitoring relays for opening and closing coils in the secondary control circuit, please check this option; Otherwise, please ignore.		
16.If there are any other special requirements, please make a note here:			

The standard configuration of circuit breakers includes:
 -Opening coil, Closing coil, Motor operator(with signal output), Alarm contact; Auxiliary contact: 4NO+4NC
 -External neutral current transformer for 3P circuit breaker with ground fault protection
 -Standard door frame, phase separator

Customer signature and seal:

GEIS

GEIS Electric

Website: www.geis.tech

Hotline: +86 400-820-5234

This catalog may be subjected to revision without prior notice.

Version No.: GENCLVAK26V2

