

GEIS

M-PACT Plus Air circuit breaker

GEIS Electrical Protection

Safer Smarter Greener



About GEIS

GEIS was established in 2019 following the spin-off of several businesses and assets that ABB had acquired from GE on July 1, 2018, including 3 manufacturing centers, Warehousing & Trading business at FTZ, China Technology Center.

- Components: Full range of circuit breakers up to 40.5kV: Medium voltage vacuum circuit breakers, LV circuit breakers: ACB, MCCB, MCB, RCD, RCBO: Control components.
- Equipment: MV switchgear (Air insulation and Gas Insulation Technology), LV switchgear, switchboard.
- Medium voltage distribution transformer.
- Medium voltage ATS system (Paralleling Switchgear).

After the separation, all the above product lines were rebranded as AEG for selected markets and GEIS for global markets. Moreover, GEIS has expanded its technological portfolio to include medium-voltage controls such as VFDs and soft starters, as well as ATS systems and EV chargers.



Quality is Built-in

Where Technology Meets Manufacturing Excellence for Customers

- Since 2000, we have been specializing in localizing world-class products and manufacturing technologies, developing strong expertise and a highly capable team.
- Vertical integrated Shanghai Manufacturing Center brought key manufacturing processes into a 75,000 m² facility, enabling high-quality, high-efficiency production and fostering innovation. A dedicated R&D team committed to developing products that meet global standards and serve diverse applications.
- Global expansion: GEIS's first Thailand facility makes it easier to serve customers worldwide.



GEIS deliver complete range of products for the evolving electrification needs:



SecoVac VCB



M-PACT Plus ACB



Elfa Series MCB/RCBO



SolidDrive MV VFD



SecoGear MV Switchgear



RMU Gas Insulated Switchgear



WaveCast Transformer



MLS LV Switchgear

M-PACT plus Air circuit breaker

01

Product Identification

09

Selection Guide

15

Technical data

19

Control Unit

45

Breaker Accessories

66

Application Guide

73

Dimensions

87

Wiring Diagrams

90

Order Codes

M-PACT plus Air circuit breaker
Product Identification

M-PACT plus Air circuit breaker

The M-PACT plus air circuit breaker is a brand-new product line from AEG, developed from the classic ME air circuit breaker series. It is a new generation product that inherits the advantages and application experience of the M-PACT air circuit breaker family. It has been upgraded with a new digital intelligent control unit to align with the current digital power environment. As a low-voltage air circuit breaker suitable for global use, it meets the standard platform requirements of GB, IEC, and UL.

The entire series is divided into three frame size current levels with a rated current ranging from 400A to 6400A and 3, 4-pole products, with a rated breaking capacity of up to 150kA and a rated voltage of up to AC1150V. The unique product design combines the need for rapid trip performance under high fault currents and selective protection under low fault currents.

The new generation of intelligent control units employs new technologies, enabling the circuit breaker to provide safer and more reliable circuit protection, as well as the measurement and display of various electrical parameters. Connectivity with the circuit breaker can be achieved via Modbus, 4G, Bluetooth, NFC, plug-and-play bus, and APP-based online monitoring. Bluetooth remote control offers a safe way to operate the circuit breaker, enhancing on-site operational safety, while NFC can read stored circuit breaker data even in the event of a power failure on site.



Features

- High-performance complete line
- Selective and fast breaking
- Reliability and safety
- New generation intelligent control unit
- Multiple human-machine interaction methods
- Easy to use & flexible installation options
- Optional installation components
- Common field mountable accessories

ACB Family



ACB

ME05

ME07

M-PACT/ME09

M-PACT plus

M-PACT plus Air circuit breaker
Product Identification

Appearance Characteristics

Circuit Breaker Front Facia



Circuit Breaker label

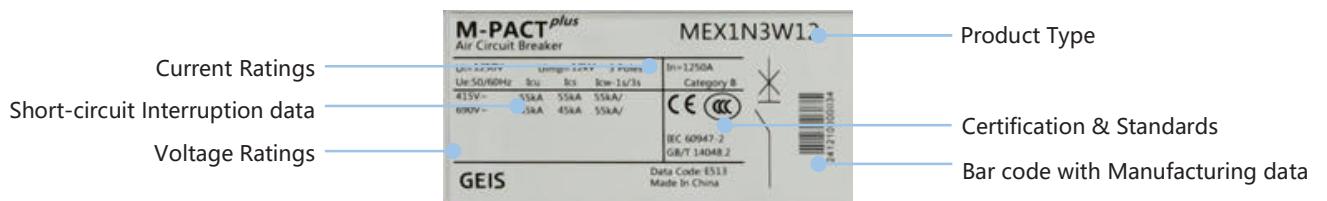

Intelligent Control Unit

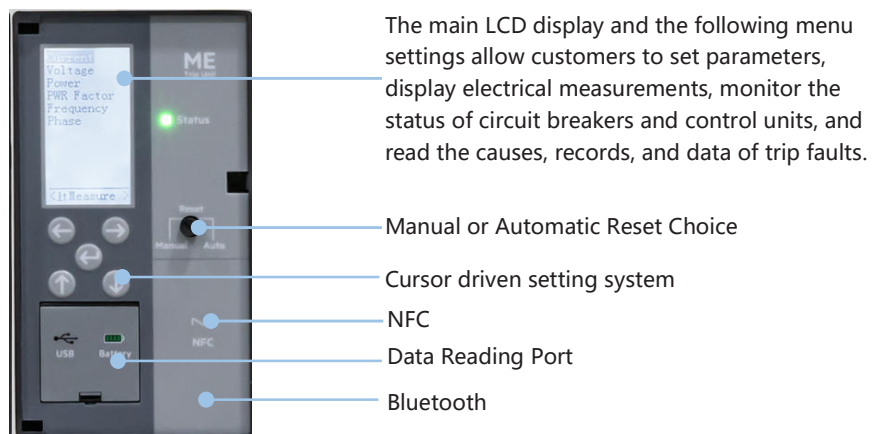

Product Identification



High-performance complete *series*

The M-PACT plus series of air circuit breakers is divided into three frame size, with a rated current range from 400 to 6400A, and available in 3 or 4 poles products.

The entire product range offers various levels of breaking capacity, and the rated operational short-circuit breaking capacity is equal to 100% of the rated ultimate short-circuit breaking capacity ($I_{cs} = 100\% I_{cu}$).

The rated current range for Frame 1 is from 400 to 2500A, with no derating required within a temperature range of 50 degrees Celsius.

The rated operational voltage can reach up to AC 690V. This type is available in interruption ratings ($I_{cs}=I_{cu}$) of 55, 70 and 85kA at AC 415V.

The rated current range for Frame 2 is from 400 to 4000A, with no derating required within a temperature range of 50 degrees Celsius. The rated operating voltage can reach up to AC 1150V. This type is available in interruption ratings ($I_{cs}=I_{cu}$) of 55, 70, 85 and 100kA at AC 415V.

The rated current range for Frame 3 is from 3200 to 6400A, with no need for derating within 50 degrees Celsius, and a maximum rated operating voltage of up to 1150V. This type is available in interruption ratings ($I_{cs}=I_{cu}$) of 100 and 150kA at AC 415V.

For breaking capacity at AC690V and above, please refer to the technical data sheet.

AC415V breaking capacity, $I_{cu}=I_{cs}$, kA

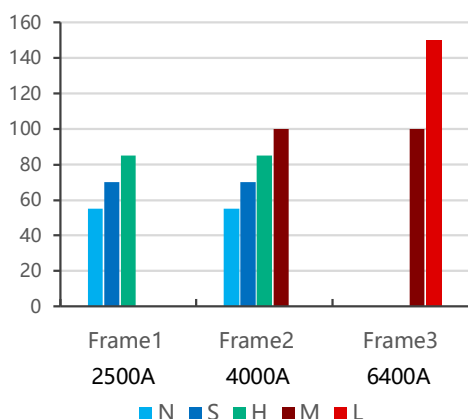

Current Ratings in Enclosures

One of the most important user parameters is not the nominal rating of an 'Air Circuit Breaker' in free air but its current Rating within a panel or enclosure.

Breakers 'enclosed ratings' are determined by the heat dissipation produced by the device and its ability to carry current at the temperature within the enclosure.

The M-PACT Plus air circuit breakers have lower power dissipation for each pole, allowing high current in high ambient temperatures. This excellent feature can be referenced in the derating curves shown in the left diagram, which illustrate the performance of both fixed and Draw-out circuit breakers at different ambient temperatures.

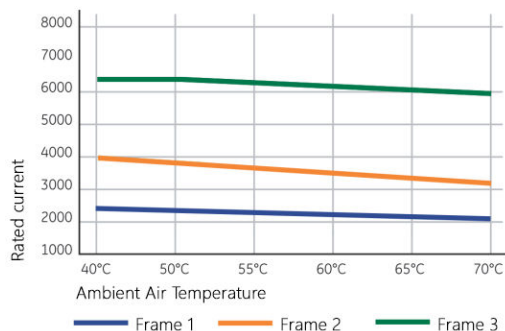

M-PACT plus Air circuit breaker

Product Identification

Selective, Fast & reliability

Selective & Fast

M-PACT plus air circuit breaker series has been designed to offer an uncompromising combination of a fast interruption at high fault levels attaining values of 30 Milliseconds or less meanwhile maintaining selectivity.

The circuit breaker will remain closed in the following situations. When the short-circuit fault current value is within the set multiple and delay time range of the short-circuit short delay protection, or within 15 milliseconds when the short-circuit fault current value has reached the set multiple of the instantaneous protection.

This short-circuit protection device and the provided setting range reliably ensure the requirement for the lower level circuit breaker to preferentially disconnect the fault current under general conditions.

Reliability

M-PACT plus series air circuit breakers represent a new generation of outstanding products, built upon over 70 years of experience in designing and manufacturing low voltage air circuit breakers.

These air Circuit Breakers uncompromisingly combine the properties of the older ME05 ME09(M-PACT) MEG(GG) lines with modern state of the art technology.

The device greatly improves the mechanical and electrical life of the product, whether it is manually operated or electrically operated with a shunt/undervoltage release installed.

Safety

In order to protect Service Personnel against the hazards of Short Circuits while working on a Power Distribution system M-PACT plus air Circuit breakers can be equipped with a so called RELT switch input.

This allows the breaker to be switched to its lowest Short-circuit settings(40ms) on service, thus limiting the hazards concerned.

The RELT switch input (with feedback) is available on the breaker auxiliary terminals or can be accessed through the wiring or communication bus.

Speed WHEN needed ... Warranted selectivity elsewhere

The simplest, standard, Electronic Trip Unit, has a broad range of timed bands at all overcurrent levels. Thus attaining selectivity between closely rated devices and across multiple distribution levels.

This strongly simplifies and economizes installation design.

ME07, ME09 (MPACT) Air circuit breakers

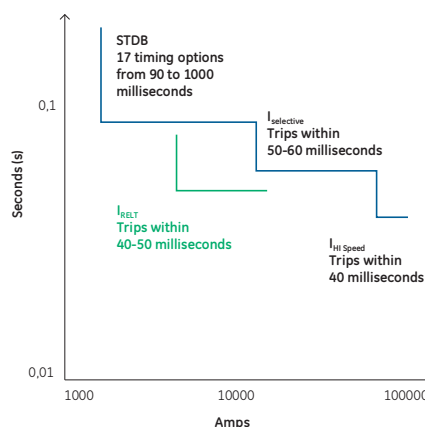

M-PACT plus Air circuit breaker
Product Identification

Protection

ME intelligent control unit



ME intelligent control unit

M-PACT plus offers a full range of air circuit breakers, including the new generation intelligent digital control units type A, type P, and type X. Featuring a unified LCD display design, providing electrical parameters such as current, convenient and accurate function menu keyboard, and a wide range of parameter and current settings.

All function menu settings can be achieved through four setting buttons and one confirmation button, allowing for quick and accurate parameter settings of the device. Users can easily choose between manual or automatic fault reset on the panel.

When the external power module is not powered on, the control unit can also be activated through an external test module with a battery.

Main adjustable options

Ir- Overload long-time protection

Overload long-time protection setting (Ir), adjustable from 0.2-1 In, with a step size of 0.1 * In or 1A. The setting range for Overload long-time tripping time is 0-24s, which can meet the overload protection requirements of different lower level loads.

Isd-Short circuit delay protection

The short-circuit short delay protection setting can be adjusted from 1.5-10 Ir (long delay setting value), with a step size of 0.5 * Ir or 1A. Short circuit short delay Tsd provides two methods: fixed time and inverse time, with a set time of 0-0.4s

Ii -Short circuit instantaneous protection

The short-circuit instantaneous protection setting can be adjusted from 2-15In, with a step size of 1 * In or 1A. The short-circuit instantaneous protection is set to ensure that the lower pole circuit breaker opens first.

Other protective features

Other optional protection functions include RELT, ground protection of vector sum, independent ground CT protection, voltage protection, frequency protection, power protection, etc. Please refer to the control unit function page of the catalogue for details.

Parameter measurement, relay and communication functions

The control unit can provide Modbus RTU communication function, capturing and recording overload, short circuit, ground tripping events and other functions.

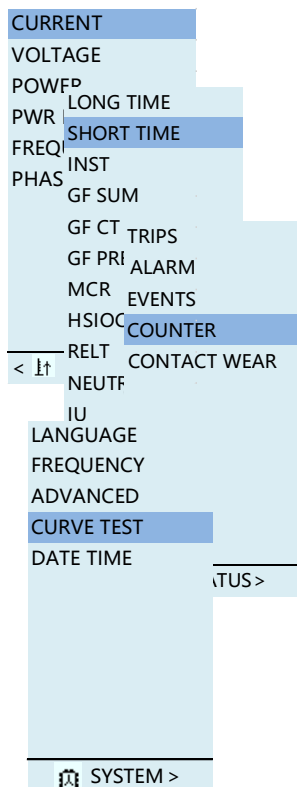

Circuit Breaker

Easy to Install & Versatile

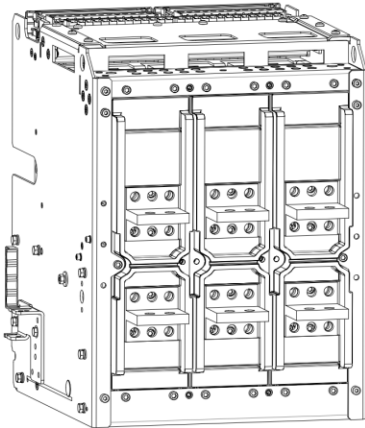

Easy to Install

M-PACT plus Air Circuit Breakers are available in a Fixed and Draw-out Pattern. Each pattern offering the highest possible current rating when enclosed in a panel or equipment .

Independent of the number of poles, rated current or interruption rating, each of the two patterns has a common height, depth and cut-out dimension. This strongly simplifying the design of panels and equipment in which these devices are used⁽¹⁾.

The breakers are installed by using easily accessible mounting brackets. All accessories are wired out to an easy to access 39 or 78 pole terminal strip mounted on the breaker top. These terminals are amply sized to allow the use of up to 2,5 mm² cabling and can be used with standard connection materials or AMP type plug connectors.

Flexible ... Kit Form

A Air Circuit Breaker is normally supplied completely fitted OFF works. However the unique modular construction and field mountable Trip Unit and accessories option can be used to acquire a breaker in kit form and to customize the device locally⁽²⁾.

Flexible ... Connections

Besides the standard horizontal connection options multiple other options are available.

Air Circuit Breakers supplied in a fixed pattern can be optionally supplied with Rear Vertical connections or Front access connections.

The Cassettes of the Breakers in Draw-out pattern are supplied with T or L stubs suitable for Horizontal Busbar connection. However these stubs can be rotated 90 degrees allowing the user to change the cassette connection option from Horizontal to Vertical Busbars.

A cassette version is available allowing Front access Connection ⁽³⁾.

(1) The width does vary

(2) With AEG's training and authorization

(3) Maximum 4000Amps

Common Field Mountable Accessories



Common Internal Accessories

A large range of internal accessories as Electrical Operators , up to four shunt Releases, Closing Coils or Undervoltage releases, Interlock Coils, Auxiliary and Alarm contacts, Carriage switches, Coil indication contacts and Breaker status switches are available.

The Air Circuit Breaker front Facia includes 'Pop up' indicators that provide the user with an overview as to which accessories are installed in the device.

Each of these devices can be acquired factory fitted or is available in a field mountable execution. The design is common to all three frame sizes.

Common External Accessories

Multiple common external accessories are available, a full overview of which can be found in accessories chapter of this catalogue.

There are five different types of circuit breaker padlocks with interchangeable cores available for customers to choose from.

Optionally groups of two or three Power Circuit Breakers in Fixed or Draw-out pattern can be interlocked. This in several different configurations, allowing the user to build an incoming power supply of multiple breakers to his own requirements.

All Interlocks and Locking devices are only supplied factory fitted, the associated locks and cables are Field mountable.

Note: There are two types of motors, 1 type exists for frame 1, 1 type exists for Frame 2 & 3.

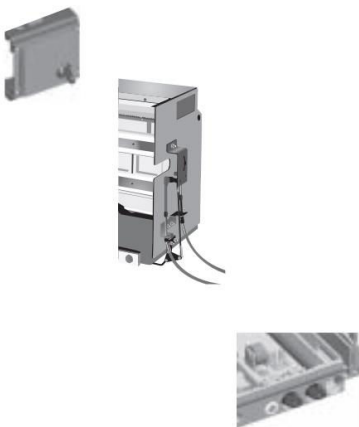

M-PACT plus Air circuit breaker
Product Identification

LV distribution system solution



Using world class design and development tools like Six Sigma, computer simulation and Lean Manufacturing, the M-PACT plus is intended to meet and exceed the most stringent quality and safety standards.

We are proud to offer a product that will offer years of reliable and dependable protection.

we devote to develop a broad range of products designed to meet our customer' s changing and competitive environment. Our drive to exceed our customer' s expectations is the foundation for continual renewal of our commitment to provide innovative low voltage solutions.

The new M-PACT plus Air Circuit Breaker and the existing Elfa miniature circuit breaker, R+ molded case circuit breaker and starter lines offer a full line of high-performance protection devices.

They provide a fully co-ordinated approach to circuit and device protection for use in the Domestic, Commercial and Industrial environment.

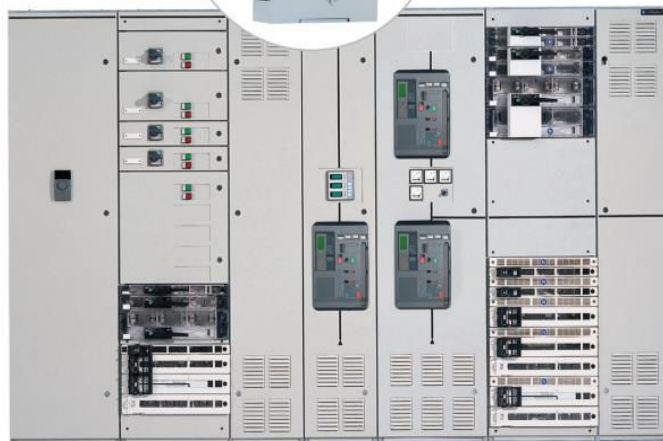

M-PACT plus Air circuit breaker

Selection Guide

Circuit breaker type quick selection

MEX	1	N	3	W	32	A03		
Product type	Frame type	Breaking capacity		Poles	Installation		Rated current	ME control unit
M-PACT plus Air circuit breaker	1 Frame1	N 55kA Frame1,Frame2	3 3P	W Draw-out	04 400A	A03		
	2 Frame2	S 70kA Frame1,Frame2	4 4P	F Fixed	06 630A	A06		
	3 Frame3	H 85kA Frame1,Frame2			08 800A	A13		
		M 100kA Frame2,Frame3			10 1000A	A16		
		L 150kA Frame3			12 1250A	P13H		
		C 66kA ¹⁾ Frame2			16 1600A	P16H		
		F 66kA ²⁾ Frame2			20 2000A	X13H		
		H 80kA ²⁾ Frame3			25 2500A	X16H		
					32 3200A	No protection ³⁾		
					40 4000A			
				50 5000A				
				64 6400A				

Note: 1) At AC 800V ;

2) At AC 1150 V ;

3) When the control unit is not selected, provide Non Automatic circuit breaker (with isolation function).

4) For breaking capacity, in all MEX series Icu = 100% Ics

5) The parameters for breaking capacity shown in the table as N, S, H, M are for AC415V. For the breaking capacities corresponding to other voltage levels, please refer to the technical data sheet.

ME control unit

Basic type	Type code	Main function
Current type	A03	LSI 3 stage protection, current measurement, optional communication ⁶⁾
	A06	LSIG 4 stage protection, current measurement, optional communication ⁶⁾
	A13	LSI 3 stage protection, current measurement, optional communication
	A16	LSIG 4 stage protection, current measurement, optional communication
Power type	P13H	LSI 3 stage protection, current, voltage, power, and frequency measurement and protection, optional communication
	P16H	LSIG 4 stage protection, current, voltage, power, and frequency measurement and protection, optional communication
Measurement Type	X13H	LSI 3 stage protection, full power measurement and protection, metering, waveform capture, Bluetooth, NFC, optional communication
	X16H	LSIG 4 stage protection, full power measurement and protection, metering, waveform capture, Bluetooth, NFC, optional communication

Note: 6) A03 and A06 control units, with optional communication modules, support remote measuring, remote signaling, and remote adjustment functions. If communication needs to achieve all four remote function, please select other control units;

Example for selection

Requirements: Rated current 2500A, 3P, draw-out type, short-circuit breaking capacity 70kA, LSI three-stage protection, current measurement

Type: MEX1S3W25A03

M-PACT plus Air circuit breaker

Selection Guide

M-PACT plus Circuit Breaker Main Parameter Specifications

Frame type	Breaking code	Rated current	Rated voltage	Icu	Ics	Icw
Frame1	N	400-2500A	AC415V	55kA	55kA	55kA
			AC690V	45kA	45kA	55kA
	S	400-2500A	AC415V	70kA	70kA	70kA
			AC690V	55kA	55kA	70kA
	H	400-2500A	AC415V	85kA	85kA	70kA
			AC690V	66kA	66kA	70kA
Frame2	N	3200-4000A	AC415V	55kA	55kA	55kA
			AC690V	55kA	55kA	55kA
	S	3200-4000A	AC415V	70kA	70kA	70kA
			AC690V	66kA	66kA	70kA
	H	400-4000A	AC415V	85kA	85kA	85kA
			AC690V	85kA	85kA	85kA
	M	400-4000A	AC415V	100kA	100kA	85kA
			AC690V	85kA	85kA	85kA
	C	400-4000A	AC800V	66kA	66kA	66kA
	F	400-4000A	AC1150V	66kA	66kA	66kA
Frame3	M	3200-6400A	AC415V	100kA	100kA	100kA
			AC690V	100kA	100kA	100kA
	L	3200-6400A	AC415V	150kA	150kA	100kA
			AC690V	100kA	100kA	100kA
	H	3200-6400A	AC1150V	65kA	65kA	65kA
H	3200-6400A	AC1150V	80kA	80kA	80kA	

Standard Configuration of Circuit Breaker

Draw-out Circuit Breaker

- Circuit breaker and draw-out base
- Control unit
- Energy storage motor, closing coil, shunt release coil
- 4NO+4NC power auxiliary contacts
- External power supply for 220V AC / 24V DC control unit
- Standard Door Flanges
- Rear T-type or L-type terminals

Fixed Circuit Breaker

- Fixed Circuit Breaker
- Control Unit
- Energy Storage Motor, Closing Coil, Shunt Release Coil
- 4NO+4NC Power Type Auxiliary Contacts
- External Power Supply for Control Unit: 220V AC / 24V DC
- Standard Door Flanges

M-PACT plus Air circuit breaker

Selection Guide

Draw-out Breaker with draw-out base - Quick selection

Breaking code	Frame	Rated current	Draw-out 3 pole	Draw-out 4 pole		Control unit
N AC 415V I _{cu} =I _{cs} =55kA I _{cw} =55kA	1	400	MEX1N3W04	MEX1N4W04	+	A03
		630	MEX1N3W06	MEX1N4W06		A06
		800	MEX1N3W08	MEX1N4W08		A13
		1000	MEX1N3W10	MEX1N4W10		A16
		1250	MEX1N3W12	MEX1N4W12		P13H
		1600	MEX1N3W16	MEX1N4W16		P16H
		2000	MEX1N3W20	MEX1N4W20		X13H
	2500	MEX1N3W25	MEX1N4W25	X16H		
	2	3200	MEX2N3W32	MEX2N4W32		Non protection
		4000	MEX2N3W40	MEX2N4W40		
	S AC 415V I _{cu} =I _{cs} =70kA I _{cw} =70kA	1	400	MEX1S3W04		MEX1S4W04
630			MEX1S3W06	MEX1S4W06		
800			MEX1S3W08	MEX1S4W08		
1000			MEX1S3W10	MEX1S4W10		
1250			MEX1S3W12	MEX1S4W12		
1600			MEX1S3W16	MEX1S4W16		
2000			MEX1S3W20	MEX1S4W20		
2500		MEX1S3W25	MEX1S4W25			
2		3200	MEX2S3W32	MEX2S4W32		
		4000	MEX2S3W40	MEX2S4W40		
H AC 415V I _{cu} =I _{cs} =85kA I _{cw} =70kA		1	400	MEX1H3W04	MEX1H4W04	
	630		MEX1H3W06	MEX1H4W06		
	800		MEX1H3W08	MEX1H4W08		
	1000		MEX1H3W10	MEX1H4W10		
	1250		MEX1H3W12	MEX1H4W12		
	1600		MEX1H3W16	MEX1H4W16		
	2000		MEX1H3W20	MEX1H4W20		
2500	MEX1H3W25	MEX1H4W25				
H AC 415/690V I _{cu} =I _{cs} =85kA I _{cw} =85kA	2	400	MEX2H3W04	MEX2H4W04		
		630	MEX2H3W06	MEX2H4W06		
		800	MEX2H3W08	MEX2H4W08		
		1000	MEX2H3W10	MEX2H4W10		
		1250	MEX2H3W12	MEX2H4W12		
		1600	MEX2H3W16	MEX2H4W16		
		2000	MEX2H3W20	MEX2H4W20		
		2500	MEX2H3W25	MEX2H4W25		
		3200	MEX2H3W32	MEX2H4W32		
4000	MEX2H3W40	MEX2H4W40				
M AC 415V I _{cu} =I _{cs} =100kA I _{cw} =85kA	2	400	MEX2M3W04	MEX2M4W04		
		630	MEX2M3W06	MEX2M4W06		
		800	MEX2M3W08	MEX2M4W08		
		1000	MEX2M3W10	MEX2M4W10		
		1250	MEX2M3W12	MEX2M4W12		
		1600	MEX2M3W16	MEX2M4W16		
		2000	MEX2M3W20	MEX2M4W20		
		2500	MEX2M3W25	MEX2M4W25		
		3200	MEX2M3W32	MEX2M4W32		
4000	MEX2M3W40	MEX2M4W40				

M-PACT plus Air circuit breaker

Selection Guide

Draw-out Breaker with draw-out base - Quick selection

Breaking code	Frame	Rated current	Draw-out 3 pole	Draw-out 4 pole	+	Control unit	
M AC 415/690V Icu=Ics=100kA Icw=100kA	3	3200	MEX3M3W32	MEX3M4W32		A03	
		4000	MEX3M3W40	MEX3M4W40		A06	
		5000	MEX3M3W50	MEX3M4W50		A13	
		6400	MEX3M3W64	MEX3M4W64		A16	
L AC 415/690V Icu=Ics=150kA Icw=100kA	3	3200	MEX3L3W32	MEX3L4W32		P13H	
		4000	MEX3L3W40	MEX3L4W40		P16H	
		5000	MEX3L3W50	MEX3L4W50		X13H	
		6400	MEX3L3W64	MEX3L4W64		X16H	
High voltage circuit breaker							
C AC 800V Icu=Ics=66kA Icw=66kA	2	400	MEX2C3W04	MEX2C4W04			Non protection
		630	MEX2C3W06	MEX2C4W06			
		800	MEX2C3W08	MEX2C4W08			
		1000	MEX2C3W10	MEX2C4W10			
		1250	MEX2C3W12	MEX2C4W12			
		1600	MEX2C3W16	MEX2C4W16			
		2000	MEX2C3W20	MEX2C4W20			
		2500	MEX2C3W25	MEX2C4W25			
		3200	MEX2C3W32	MEX2C4W32			
4000	MEX2C3W40	MEX2C4W40					
F AC 1150V Icu=Ics=66kA Icw=66kA	2	400	MEX2F3W04	MEX2F4W04			
		630	MEX2F3W06	MEX2F4W06			
		800	MEX2F3W08	MEX2F4W08			
		1000	MEX2F3W10	MEX2F4W10			
		1250	MEX2F3W12	MEX2F4W12			
		1600	MEX2F3W16	MEX2F4W16			
		2000	MEX2F3W20	MEX2F4W20			
		2500	MEX2F3W25	MEX2F4W25			
L AC 1150V Icu=Ics=65kA Icw=65kA	3	3200	MEX3L3W32	MEX3L4W32			
		4000	MEX3L3W40	MEX3L4W40			
		5000	MEX3L3W50	MEX3L4W50			
		6400	MEX3L3W64	MEX3L4W64			
H AC 1150V Icu=Ics=80kA Icw=80kA	3	3200	MEX3H3W32	MEX3H4W32			
		4000	MEX3H3W40	MEX3H4W40			
		5000	MEX3H3W50	MEX3H4W50			
		6400	MEX3H3W64	MEX3H4W64			

M-PACT plus Air circuit breaker

Selection Guide

Fixed circuit breaker - Quick selection

Breaking code	Frame	Rated current	Fixed 3 pole	Fixed 4 pole		Control unit	
N AC 415V Icu=Ics=55kA Icw=55kA	1	400	MEX1N3F04	MEX1N4F04	+	A03	
		630	MEX1N3F06	MEX1N4F06		A06	
		800	MEX1N3F08	MEX1N4F08		A13	
		1000	MEX1N3F10	MEX1N4F10		A16	
		1250	MEX1N3F12	MEX1N4F12		P13H	
		1600	MEX1N3F16	MEX1N4F16		P16H	
		2000	MEX1N3F20	MEX1N4F20		X13H	
	2500	MEX1N3F25	MEX1N4F25	X16H			
	2	3200	MEX2N3F32	MEX2N4F32		Non protection	
		4000	MEX2N3F40	MEX2N4F40			
		1	400	MEX1S3F04		MEX1S4F04	
			630	MEX1S3F06		MEX1S4F06	
			800	MEX1S3F08		MEX1S4F08	
			1000	MEX1S3F10		MEX1S4F10	
1250			MEX1S3F12	MEX1S4F12			
1600	MEX1S3F16		MEX1S4F16				
2000	MEX1S3F20		MEX1S4F20				
2	2500	MEX1S3F25	MEX1S4F25				
	3200	MEX2S3F32	MEX2S4F32				
4000	MEX2S3F40	MEX2S4F40					
H AC 415V Icu=Ics=85kA Icw=70kA	1	400	MEX1H3F04	MEX1H4F04			
		630	MEX1H3F06	MEX1H4F06			
		800	MEX1H3F08	MEX1H4F08			
		1000	MEX1H3F10	MEX1H4F10			
		1250	MEX1H3F12	MEX1H4F12			
		1600	MEX1H3F16	MEX1H4F16			
		2000	MEX1H3F20	MEX1H4F20			
2500	MEX1H3F25	MEX1H4F25					
H AC 415/690V Icu=Ics=85kA Icw=85kA	2	400	MEX2H3F04	MEX2H4F04			
		630	MEX2H3F06	MEX2H4F06			
		800	MEX2H3F08	MEX2H4F08			
		1000	MEX2H3F10	MEX2H4F10			
		1250	MEX2H3F12	MEX2H4F12			
		1600	MEX2H3F16	MEX2H4F16			
		2000	MEX2H3F20	MEX2H4F20			
		2500	MEX2H3F25	MEX2H4F25			
		3200	MEX2H3F32	MEX2H4F32			
4000	MEX2H3F40	MEX2H4F40					
M AC 415V Icu=Ics=100kA Icw=85kA	2	400	MEX2M3F04	MEX2M4F04			
		630	MEX2M3F06	MEX2M4F06			
		800	MEX2M3F08	MEX2M4F08			
		1000	MEX2M3F10	MEX2M4F10			
		1250	MEX2M3F12	MEX2M4F12			
		1600	MEX2M3F16	MEX2M4F16			
		2000	MEX2M3F20	MEX2M4F20			
		2500	MEX2M3F25	MEX2M4F25			
		3200	MEX2M3F32	MEX2M4F32			
4000	MEX2M3F40	MEX2M4F40					

M-PACT plus Air circuit breaker

Selection Guide

Fixed circuit breaker - Quick selection

Breaking code	Frame	Rated current	Fixed 3 pole	Fixed 4 pole	Control unit
M AC 415/690V I _{cu} =I _{cs} =100kA I _{cw} =100kA	3	3200	MEX3M3F32	MEX3M4F32	A03
		4000	MEX3M3F40	MEX3M4F40	A06
		5000	MEX3M3F50	MEX3M4F50	A13
		6400	MEX3M3F64	MEX3M4F64	A16
L AC 415/690V I _{cu} =I _{cs} =150kA I _{cw} =100kA	3	3200	MEX3L3F32	MEX3L4F32	P13H
		4000	MEX3L3F40	MEX3L4F40	P16H
		5000	MEX3L3F50	MEX3L4F50	X13H
		6400	MEX3L3F64	MEX3L4F64	X16H
High voltage circuit breaker					
C AC 800V I _{cu} =I _{cs} =66kA I _{cw} =66kA	2	400	MEX2C3F04	MEX2C4F04	Non protection
		630	MEX2C3F06	MEX2C4F06	
		800	MEX2C3F08	MEX2C4F08	
		1000	MEX2C3F10	MEX2C4F10	
		1250	MEX2C3F12	MEX2C4F12	
		1600	MEX2C3F16	MEX2C4F16	
		2000	MEX2C3F20	MEX2C4F20	
		2500	MEX2C3F25	MEX2C4F25	
		3200	MEX2C3F32	MEX2C4F32	
F AC 1150V I _{cu} =I _{cs} =66kA I _{cw} =66kA	2	400	MEX2F3F04	MEX2F4F04	
		630	MEX2F3F06	MEX2F4F06	
		800	MEX2F3F08	MEX2F4F08	
		1000	MEX2F3F10	MEX2F4F10	
		1250	MEX2F3F12	MEX2F4F12	
		1600	MEX2F3F16	MEX2F4F16	
		2000	MEX2F3F20	MEX2F4F20	
		2500	MEX2F3F25	MEX2F4F25	
		3200	MEX2F3F32	MEX2F4F32	
L AC 1150V I _{cu} =I _{cs} =65kA I _{cw} =65kA	3	3200	MEX3L3F32	MEX3L4F32	
		4000	MEX3L3F40	MEX3L4F40	
		5000	MEX3L3F50	MEX3L4F50	
		6400	MEX3L3F64	MEX3L4F64	
H AC 1150V I _{cu} =I _{cs} =80kA I _{cw} =80kA	3	3200	MEX3H3F32	MEX3H4F32	
		4000	MEX3H3F40	MEX3H4F40	
		5000	MEX3H3F50	MEX3H4F50	
		6400	MEX3H3F64	MEX3H4F64	

M-PACT plus Air circuit breaker

Technical data

MEX1 air circuit breaker technical data				N	S	H
Breaking capacity code						
Rated current	In	A	400-2500	400-2500	400-2500	
Pole			3P, 4P	3P, 4P	3P, 4P	
Rated isolation voltage	Ui	V	1250	1250	1250	
Rated impulse withstand voltage	Uimp	kV	12	12	12	
Rated operational voltage	Ue	V	AC415/690	AC415/690	AC415/690	
Utilization category			B	B	B	
Isolation function			Yes	Yes	Yes	
Rated current in neutral pole			100% phase line	100% phase line	100% phase line	
Breaking parameter						
Ultimate breaking capacity Icu	AC415V	kA	55	70	85	
	AC690V	kA	45	55	66	
Service breaking capacity Ics	AC415V	kA	55	70	85	
	AC690V	kA	45	55	66	
Short-circuit withstand Icw (1s)	AC415V	kA	55	70	70	
	AC690V	kA	55	70	70	
Short-circuit withstand Icw (3s)	AC415V	kA	-	55	55	
	AC690V	kA	-	55	55	
Short-circuit Making current (Icm)	AC415V	kA	121	154	187	
	AC690V	kA	99	121	145	
ME control unit						
	Type A	Current type	<input type="checkbox"/>	<input type="checkbox"/>	<input type="checkbox"/>	
	Type P	Power type	<input type="checkbox"/>	<input type="checkbox"/>	<input type="checkbox"/>	
	Type X	Measurement type	<input type="checkbox"/>	<input type="checkbox"/>	<input type="checkbox"/>	
Non automatic circuit breaker			<input type="checkbox"/>	<input type="checkbox"/>	<input type="checkbox"/>	
Operation performance						
Mechanical endurance	With Maintenance	Times	40000	40000	40000	
	Without Maintenance	Times	25000	25000	25000	
Electrical endurance, AC415V, Electrical endurance						
	400-1600A	Times	12000	12000	12000	
	2000A	Times	10000	10000	10000	
	2500A	Times	8000	8000	8000	
Total breaking time			ms	≤30	≤30	
Closing time			ms	≤60	≤60	
Installation						
Fixed pattern						
	Height	mm	442	442	442	
	Width 3 pole	mm	343	343	343	
	Width 4 pole	mm	443	443	443	
	Depth	mm	355	355	355	
Available connection modes	Rear Horizontal		■	■	■	
	Rear Vertical		□	□	□	
Weights	3pole	kg	64	64	64	
	4pole	kg	75	75	75	
Draw-out pattern						
	Height	mm	464	464	464	
	Width 3 pole	mm	360	360	360	
	Width 4 pole	mm	460	460	460	
	Depth	mm	485	485	485	
Rear Universal	Rear Horizontal ⁽¹⁾		■	■	■	
Weights	3pole	kg	109	109	109	
	4pole	kg	121	121	121	

Notes: ■Standard configuration □Optional configuration;

(1) The rear T-type terminal can be flipped, suitable for both horizontal and vertical connection configurations.

M-PACT plus Air circuit breaker

Technical data

MEX2 air circuit breaker technical data				N	S	H	M
Breaking capacity code							
Rated current	In	A	3200-4000	3200-4000	400-4000	400-4000	
Pole			3P, 4P	3P, 4P	3P, 4P	3P, 4P	
Rated isolation voltage	Ui	V	1250	1250	1250	1250	
Rated impulse withstand voltage	Uimp	kV	12	12	12	12	
Rated operational voltage	Ue	V	AC415/690	AC415/690	AC415/690	AC415/690	
Utilization category				B	B	B	B
Isolation function				Yes	Yes	Yes	Yes
Rated current in neutral pole				100% phase line	100% phase line	100% phase line	100% phase line
Breaking parameter							
Ultimate breaking capacity Icu	AC415V	kA	55	70	85	100	
	AC690V	kA	55	66	85	85	
Service breaking capacity Ics	AC415V	kA	55	70	85	100	
	AC690V	kA	55	66	85	85	
Short-circuit withstand Icw (1s)	AC415V	kA	55	70	85	85	
	AC690V	kA	55	70	85	85	
Short-circuit withstand Icw (3s)	AC415V	kA	55	55	55	66	
	AC690V	kA	55	55	55	66	
Short-circuit Making current (Icm)	AC415V	kA	121	154	187	220	
	AC690V	kA	121	145	187	187	
ME control unit							
	Type A	Current type	<input type="checkbox"/>	<input type="checkbox"/>	<input type="checkbox"/>	<input type="checkbox"/>	
	Type P	Power type	<input type="checkbox"/>	<input type="checkbox"/>	<input type="checkbox"/>	<input type="checkbox"/>	
	Type X	Measurement type	<input type="checkbox"/>	<input type="checkbox"/>	<input type="checkbox"/>	<input type="checkbox"/>	
Non automatic circuit breaker				<input type="checkbox"/>	<input type="checkbox"/>	<input type="checkbox"/>	<input type="checkbox"/>
Operation performance							
	With Maintenance	Times	30000	30000	30000	30000	
	Without Maintenance	Times	20000	20000	20000	20000	
Electrical endurance, AC415V							
	400-1600A	Times	-	-	12000	12000	
	2000A	Times	-	-	10000	10000	
	2500A	Times	-	-	8000	8000	
	3200A		7000	7000	7000	7000	
	4000A		6000	6000	6000	6000	
Total breaking time		ms	≤30	≤30	≤30	≤30	
Closing time		ms	≤60	≤60	≤60	≤60	
Installation							
Fixed pattern							
	Height	mm	442	442	442	442	
	Width 3 pole	mm	436	436	436	436	
	Width 4 pole	mm	566	566	566	566	
	Depth	mm	355	355	355	355	
Available connection modes	Rear Horizontal		■	■	■	■	
	Rear Vertical		□	□	□	□	
Weights	3pole	kg	84	84	84	84	
	4pole	kg	96	96	96	96	
Draw-out pattern							
	Height	mm	464	464	464	464	
	Width 3 pole	mm	460	460	460	460	
	Width 4 pole	mm	590	590	590	590	
	Depth	mm	488	488	488	488	
Rear Universal	Rear Horizontal ⁽²⁾		■	■	■	■	
Weights	3pole	kg	156	156	156	156	
	4pole	kg	174	174	174	174	

Note: ■Standard configuration □Optional configuration;

(1) Vertical rear connections require additional connection options; it is recommended to use vertical connections for 4000A.

(2) The rear T-type terminal can be flipped, suitable for both horizontal and vertical connection configurations at the rear. For 4000A, vertical connection is recommended.

M-PACT plus Air circuit breaker

Technical data

MEX3 air circuit breaker technical data				M	L
Breaking capacity code					
Rated current	In	A	3200-6400	3200-6400	
Pole			3P, 4P	3P, 4P	
Rated isolation voltage	Ui	V	1250	1250	
Rated impulse withstand voltage	Uimp	kV	12	12	
Rated operational voltage	Ue	V	AC415/690	AC415/690	
Utilization category			B	B	
Isolation function			Yes	Yes	
Rated current in neutral pole			100% phase line	100% phase line	
Breaking parameter					
Ultimate breaking capacity Icu	AC415V	kA	100	150	
	AC690V	kA	100	100	
Service breaking capacity Ics	AC415V	kA	100	150	
	AC690V	kA	100	100	
Short-circuit withstand Icw (1s)	AC415V	kA	100	100	
	AC690V	kA	100	100	
Short-circuit withstand Icw (3s)	AC415V	kA	85	85	
	AC690V	kA	85	85	
Short-circuit Making current (Icm)	AC415V	kA	220	330	
	AC690V	kA	220	220	
ME control unit					
	Type A	Current type	<input type="checkbox"/>	<input type="checkbox"/>	
	Type P	Power type	<input type="checkbox"/>	<input type="checkbox"/>	
	Type X	Measurement type	<input type="checkbox"/>	<input type="checkbox"/>	
Non automatic circuit breaker			<input type="checkbox"/>	<input type="checkbox"/>	
Operation performance					
	With Maintenance	Times	20000	20000	
	Without Maintenance	Times	12500	12500	
Electrical endurance, AC415V					
	3200A	Times	12000	12000	
	4000A	Times	10000	10000	
	5000A	Times	8000	8000	
	6400A		6000	6000	
Total breaking time		ms	≤30	≤30	
Closing time		ms	≤60	≤60	
Installation					
Fixed pattern					
	Height	mm	442	442	
	Width 3 pole	mm	736	736	
	Width 4 pole	mm	966	966	
	Depth	mm	355	355	
Available connection modes	Rear Horizontal		<input checked="" type="checkbox"/>	<input checked="" type="checkbox"/>	
	Rear Vertical		<input type="checkbox"/>	<input type="checkbox"/>	
Weights	3pole	kg	141	141	
	4pole	kg	153	153	
Draw-out pattern					
	Height	mm	443	443	
	Width 3 pole	mm	743	743	
	Width 4 pole	mm	943	943	
	Depth	mm	522	522	
Rear Universal	Rear Horizontal ⁽²⁾		<input checked="" type="checkbox"/>	<input checked="" type="checkbox"/>	
Weights	3pole	kg	291	291	
	4pole	kg	313	313	

Note: ■Standard configuration □Optional configuration;

(1) Vertical rear connections require additional connection options; it is recommended to use vertical connections for 6400A.

(2) The rear T-type terminal can be flipped, suitable for both horizontal and vertical connection configurations at the rear. For 6400A, vertical connection is recommended

M-PACT plus Air circuit breaker

Technical data

MEX high voltage air circuit breaker technical data						
Breaking capacity code			MEX2		MEX3	
Rated current			C	F	L	H
Pole	In	A	400-4000	400-4000	3200-6400	3200-6400
Rated isolation voltage			3P, 4P	3P, 4P	3P, 4P	3P, 4P
Rated impulse withstand voltage	Ui	V	1250	1250	1250	1250
Rated operational voltage	Uimp	kV	12	12	12	12
Utilization category	Ue	V	AC800	AC1150	AC1150	AC1150
Isolation function			B	B	B	B
Rated current in neutral pole			Yes	Yes	Yes	Yes
Breaking parameter			100% phase line	100% phase line	100% phase line	100% phase line
Ultimate breaking capacity Icu	AC415/690/800V	kA	66	-	-	-
	AC415/690/1150V	kA	-	66	65	80
	AC415/690/1500V	kA	-	-	-	-
Service breaking capacity Ics	AC415/690/800V	kA	66	-	-	-
	AC415/690/1150V	kA	-	66	65	80
	AC415/690/1500V	kA	-	-	-	-
Short-circuit withstand Icw (1s)		kA	66	66	65	80
Short-circuit withstand Icw (3s)		kA	55	55	-	-
Short-circuit Making current Icm		kA	145	145	143	176
ME control unit						
	Type A	Current type	<input type="checkbox"/>	<input type="checkbox"/>	<input type="checkbox"/>	<input type="checkbox"/>
	Type P	Power type	<input type="checkbox"/>	<input type="checkbox"/>	<input type="checkbox"/>	<input type="checkbox"/>
	Type X	Measurement type	<input type="checkbox"/>	<input type="checkbox"/>	<input type="checkbox"/>	<input type="checkbox"/>
Non automatic circuit breaker			<input type="checkbox"/>	<input type="checkbox"/>	<input type="checkbox"/>	<input type="checkbox"/>
Operation performance						
Electrical endurance	With Maintenance	Times	30000	30000	20000	20000
	Without Maintenance	Times	20000	20000	12500	12500
Total breaking time		ms	≤30	≤30	≤30	≤30
Closing time		ms	≤60	≤60	≤60	≤60
Installation						
Fixed pattern						
	Height	mm	442	442	442	442
	Width 3 pole	mm	436	436	736	736
	Width 4 pole	mm	566	566	966	966
	Depth	mm	355	355	355	355
Available connection modes	Rear Horizontal		■	■	■	■
	Rear Vertical		<input type="checkbox"/>	<input type="checkbox"/>	<input type="checkbox"/>	<input type="checkbox"/>
Weights	3pole	kg	84	84	141	141
	4pole	kg	96	96	153	153
Draw-out pattern						
	Height	mm	464	464	443	443
	Width 3 pole	mm	460	460	743	743
	Width 4 pole	mm	590	590	943	943
	Depth	mm	488	488	522	522
Available connection modes	Rear Horizontal ⁽²⁾		■	■	■	■
	3pole	kg	156	156	291	291
Weights	4pole	kg	174	174	313	313

Note: ■Standard configuration □Optional configuration;

(1) Vertical rear connections require additional connection options; it is recommended to use vertical connections for Frame2 4000A and Frame 3 6400A.

(2) The rear T-type terminal can be flipped, suitable for both horizontal and vertical connection configurations at the rear. For Frame 2 4000A and Frame 3 6400A, vertical connection is recommended.

M-PACT plus Air circuit breaker Control Unit

ME New generation intelligent control unit

The M-PACT plus circuit breakers can be configured with three basic types of digital electronic control units: A, P, and X types. Each basic type of control unit has the same design appearance, a wide adjustable range of rated current (0.2-1In), and a simple and precise breaker parameter setting menu.

The A-type control unit provides an ammeter function.

The P-type control unit provides current, voltage, power, and frequency measurement functions.

The X-type control unit provides comprehensive electrical parameter measurement, large-screen color display functions, and metering capabilities.

The functionality menu of the control unit can be conveniently and accurately set using four setting keys and one confirmation key.

When the device is not yet connected to power supply, the control unit can be activated through a power module that is standard configuration for a circuit breaker.

During normal operation, the control unit is powered by built-in induction coils or an external auxiliary power module.

Without an external power supply, once the circuit breaker is loaded and the current loaded reaches 20% of the circuit breaker rated current, the control unit is activated.

When not connected to power supply, the internal battery of the A-type and P-type control units can also power the control unit (the X-type requires an external power supply). When pressing the "Left/Return" button on the control unit, the internal battery will activate the control unit and keep the LCD screen on for 10 seconds after the button is released. Once the control unit is activated, customers are allowed to perform basic parameter settings, browse the ammeter, and access the event log functions.

The control unit can also be powered by connecting a DC 5V power supply through the USB interface, and parameters can be set and read by connecting to a host computer.

The X type can set protection parameters and read electrical parameters via Bluetooth. By connecting the DO and the open/close buttons, it can achieve Bluetooth-controlled circuit breaker operations.

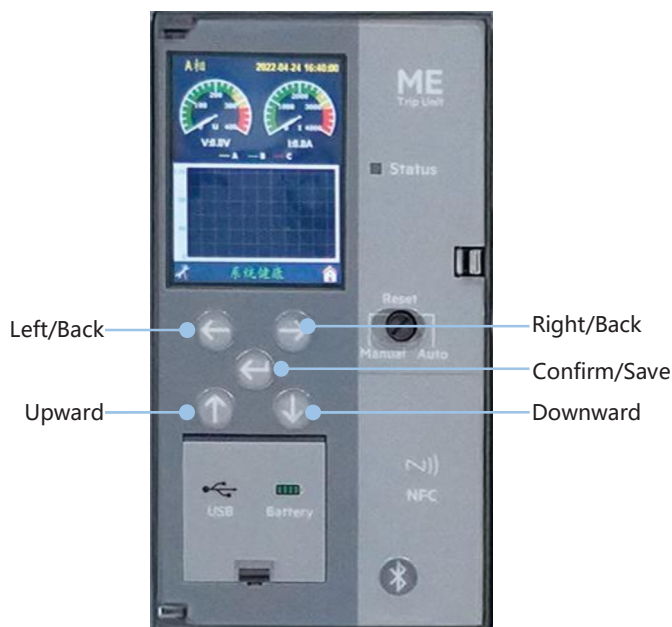

M-PACT plus Air circuit breaker

Control Unit

Basic Protection

		A03	A06	A13	A16	P13H	P16H	X13H	X16H	Default
Control unit interface	LCD Screen	•	•	•	•	•	•	•	•	
	Touch pad button	-	-	-	-	-	-	•	•	
	Multilingual, Chinese/English	•	•	•	•	•	•	•	•	Chinese
	Adjustable Manual or Automatic RESET option	•	•	•	•	•	•	•	•	
Overload long time protection, Ir	Ir Setting Range, 0.2-1In, Step length 1A	•	•	•	•	•	•	•	•	1xIn
	Trip time tr setting range, 0.5-24s, Step length 0.1s	•	•	•	•	•	•	•	•	0.1s
	Short-circuit short-time delay protection status setting, off/trip	•	•	•	•	•	•	•	•	Trip
Short Time Short-circuit Current Protection Isd	Isd setting range, 1.5-10Ir, step length 1A, OFF	•	•	•	•	•	•	•	•	1.5xIn
	Trip Time Tsd (I ² T ON) Setting Range, 0.1-0.4s, Step length 0.1s	•	•	•	•	•	•	•	•	
	Trip time Tsd (I ² T OFF) Setting Range, 0-0.4s, Step length 0.1s		•	•	•	•	•	•	•	0.1s
Instantaneous Short-circuit Current Protection Ii	Short-circuit short-time delay protection status setting, off/trip	•	•	•	•	•	•	•	•	Trip
	Ii Setting Range, 2-15In, Step length 1A (Accuracy: ±10%)	•	•	•	•	•	•	•	•	2xIn
Ground Sum protection, Ig	Ground Fault Protection Status Settings: Off/Trip/Alarm	-	•	-	•	-	•	-	•	OFF
	Ig Setting Range, 0.2-1In, Step length 1A (Accuracy: ±10%)	-	•	-	•	-	•	-	•	0.2xIn
	Trip Time Tsd (I ² T ON) Setting Range, 0.1-0.4s, Step length 0.1s	-	•	-	•	-	•	-	•	0.1s
	Trip time Tsd (I ² T OFF) Setting Range, 0-0.4s, Step length 0.1s	-	•	-	•	-	•	-	•	0.1s
Ground CT protection	Ground Fault CT Protection Status Settings: Off/Trip/Alarm	-	•	-	•	-	•	-	•	OFF
	Ig Setting Range, 0.2-1In, Step length 1A (Accuracy: ±10%)	-	•	-	•	-	•	-	•	0.2xIn
	Trip time Tg (I ² T ON) Setting Range, 0.1-0.4s, Step length 0.1s	-	•	-	•	-	•	-	•	0.1s
	Trip time Tg (I ² T OFF) Setting Range, 0-0.4s, Step length 0.1s	-	•	-	•	-	•	-	•	0.1s
Ground fault Pre-alarm	Pre-alarm mode setting, OFF/GFSUM/GFCT	-	•	-	•	-	•	-	•	OFF
	Action Value Setting Range, 120-1200A, Step length 1A	-	•	-	•	-	•	-	•	200A
	Pre-alarm time, 1-10s, Step length 0.1s	-	•	-	•	-	•	-	•	10
	Return Value Setting Range, 120-1200A, Step length 1A	-	•	-	•	-	•	-	•	120A
	Return Time, 1-10s, Step length 0.1s	-	•	-	•	-	•	-	•	10
neutral phase protection	N-phase protection mode setting, OFF/Trip	○	○	○	○	○	○	○	○	Trip
	N-phase action value, 50%-160%	○	○	○	○	○	○	○	○	100%
MCR and HSIOC protection	MCR protection mode, Trip/OFF	•	•	•	•	•	•	•	•	Trip
	MCR action value, 30In/Short time withstand Capacity		•	•	•	•	•	•	•	30In, ≤Icw
	HSIOC Protection, Mode trip	•	•	•	•	•	•	•	•	Trip
	Action value, 30In/Short time withstand Capacity	•	•	•	•	•	•	•	•	30In, ≤Icw
	Non-tripping Time, >20ms	•	•	•	•	•	•	•	•	
	Maximum Trip Time, ≤80ms	•	•	•	•	•	•	•	•	
Reduced Instantaneous (RELT)	RELT Status Settings, OFF/trip	•	•	•	•	•	•	•	•	OFF
	RELT Threshold Setting, 2-15In, Step length 1A	•	•	•	•	•	•	•	•	10In
	Non-tripping Time, >20ms	•	•	•	•	•	•	•	•	
	Maximum Trip Time, ≤80ms	•	•	•	•	•	•	•	•	

• : Standard configuration ○ : Optional configuration - : This feature is not available.

M-PACT plus Air circuit breaker

Control Unit

Advanced Protection

		A03	A06	A13	A16	P13H	P16H	X13H	X16H	Default
Overvoltage and Undervoltage Protection	Protection mode settings: OFF/TRIP/ALARM	-	-	-	-	●	●	●	●	OFF
	Action value setting, 20V~1500V, Step length 1A (Accuracy: ±10%)	-	-	-	-	●	●	●	●	280V
	Time setting, 0.1~300s, Step length 1s	-	-	-	-	●	●	●	●	10s
	Return value, 20V ~ 1500V, Step length 1V	-	-	-	-	●	●	●	●	360V
	Return time, 0.1~300s, Step length 1s	-	-	-	-	●	●	●	●	10s
Voltage Imbalance Protection	Protection mode settings: OFF/TRIP/ALARM	-	-	-	-	●	●	●	●	OFF
	Action value setting, 2%~90%, Step length 1% (Accuracy: ±10%)	-	-	-	-	●	●	●	●	20%
	Protection time setting, 0.1~300s, Step length 1s	-	-	-	-	●	●	●	●	10s
	Return value, 2%~90%, Step length 1% (Accuracy: ±10%)	-	-	-	-	●	●	●	●	10%
	Return time, 0.1~300s, Step length 1s	-	-	-	-	●	●	●	●	10s
Underfrequency Protection	Protection mode settings: OFF/TRIP/ALARM	-	-	-	-	●	●	●	●	OFF
	Action value setting, 40-70Hz, Step length 0.1Hz (Accuracy: ±10%)	-	-	-	-	●	●	●	●	45
	Protection time setting, 0.1~300s, Step length 1s	-	-	-	-	●	●	●	●	10s
	Return value, 40-70Hz, Step length 0.1Hz (Accuracy: ±10%)	-	-	-	-	●	●	●	●	49
	Return time, 0.1~300s, Step length 1s	-	-	-	-	●	●	●	●	10s
Overfrequency Protection	Protection mode settings: OFF/TRIP/ALARM	-	-	-	-	●	●	●	●	OFF
	Action value setting, 40-70Hz, Step length 0.1Hz (Accuracy: ±10%)	-	-	-	-	●	●	●	●	55
	Protection time setting, 0.1~300s, Step length 1s	-	-	-	-	●	●	●	●	10s
	Return value, 40-70Hz, Step length 0.1Hz (Accuracy: ±10%)	-	-	-	-	●	●	●	●	51
	Return time, 0.1~300s, Step length 1s	-	-	-	-	●	●	●	●	10s
Reverse Power Protection	Protection mode settings: OFF/TRIP/ALARM	-	-	-	-	●	●	●	●	OFF
	Protection action value setting, 50kW~5000kW, Step length 10kW (Accuracy: ±10%)	-	-	-	-	●	●	●	●	55
	Protection time setting, 0.1~300s, Step length 1s	-	-	-	-	●	●	●	●	10s
	Return value, 50-5000kW, Step length 10kW (Accuracy: ±10%)	-	-	-	-	●	●	●	●	51
	Return time, 0.1~300s, Step length 1s	-	-	-	-	●	●	●	●	10s
Phase sequence protection	Protection mode settings: OFF/TRIP/ALARM	●	●	●	●	●	●	●	●	OFF
	Action value, a-b-c/a-c-b	●	●	●	●	●	●	●	●	a-b-c
Others	Zone Selective Interlock	-	-	●	●	●	●	●	●	
	Communication ¹⁾	○	○	○	○	○	○	○	○	
	DC 24V power supply	●	●	●	●	●	●	●	●	
	Test Module	○	○	○	○	○	○	○	○	

● : Standard configuration ○ : Optional configuration - : This feature is not available.

Note: 1) A03 and A06 control units, with optional communication modules, support remote measuring, remote signaling, and remote adjustment functions. If communication needs to achieve all four remote function, please select other control units.

M-PACT plus Air circuit breaker
Control Unit

Measurement and Maintenance

		A03	A06	A13	A16	P13H	P16H	X13H	X16H	Default
Meter	Current Measurement (Ia, Ib, Ic, In, Ig, IgCT)	•	•	•	•	•	•	•	•	
	Voltage Measurement (Ua, Ub, Uc, Uab, Uac, Ubc)	-	-	-	-	•	•	•	•	
	Total Electricity Consumption (kW-h)	-	-	-	-	-	-	•	•	
	Active Power Measurement (L1, L2, L3) (kW)	-	-	-	-	•	•	•	•	
	Reactive Power Measurement (L1, L2, L3) (kVar)	-	-	-	-	•	•	•	•	
	Apparent Power Measurement (L1, L2, L3) (kVA)	-	-	-	-	•	•	•	•	
	Power Factor (L1, L2, L3)	-	-	-	-	•	•	•	•	
	Frequency Measurement	-	-	-	-	•	•	•	•	
	Phase Detection	-	-	-	-	•	•	•	•	
	Waveform Capture							•	•	
Status	Fault Record	•	•	•	•	•	•	•	•	
	Alarm Record	•	•	•	•	•	•	•	•	
	Event Record	•	•	•	•	•	•	•	•	
	Number of Operations	•	•	•	•	•	•	•	•	
	Contact Wear	•	•	•	•	•	•	•	•	

• : Standard configuration ◦ : Optional configuration - : This feature is not available.

M-PACT plus Air circuit breaker

Control Unit

Function menu

On the control unit, pressing the left button can light up the screen, by pressing the 'left button' Pressing the right arrow key can enter the corresponding protection menu, measurement menu, maintenance record menu, system settings menu, and other interfaces to complete all function settings and parameter viewing.

Meter

The meter function can be accessed through the display screen and by pressing the "left" and "right" keys. Press the "confirm" key to enter different electrical parameter display options, and press the "up" and "down" keys to read and observe load current, voltage, apparent, active, reactive power, and other electrical parameters. All current and voltage measurements are based on true RMS.

The control unit of M-PACT plus provides ammeter function, and A/X type provides complete electrical parameter measurement function. The ammeter and electrical parameter measurement functions require power supply to the control unit, which can be achieved through internal power supply, external battery pack, or grid power supply. The complete electrical parameter measurement function requires an external 3-phase voltage transformer and transmitter.

CURRENT
VOLTAGE
POWER
PWR FACTOR
FREQUENCY
PHASE
< ⏪ METER >

LONG TIME
SHORT TIME
INST
GF SUM
GF CT
GF PREALARM
MCR
HSIOC
RELT
NEUTRAL
IU
< ⏪ PROTECTION >

Protection

The ME control unit of the circuit breaker can provide Overload long-time (I_r), adjustable overload long delay curve (t_r), adjustable short-circuit short delay protection function (I_{sd} , t_{sd}), and adjustable short-circuit instantaneous protection function (I_i). According to the different models selected by the customer, the control unit also has other advanced protection functions: ground fault, overvoltage and undervoltage, phase sequence, current imbalance, power, frequency, input/output relays, area interlocking, etc. The specific functional details will be described in detail in this chapter.

Status

Select the "Status" function menu through the display screen and press the "Left" and "Right" keys. Press the confirm button to view the corresponding records. You can view data such as fault records, alarm records, event records, and operation times. This function requires an external 24VDC power supply to ensure the continuous operation of the control unit and complete event recording.

TRIPS	LANGUAGE
ALARMS	FREQUENCY
EVENTS	ADVANCED
COUNTER	CURVE TEST
CONTACT WEAR	DATE TIME
CLR HISTORY	
👁 STATUS >	⚙ SYSTEM >

System settings

Select the "System" function through the display screen and press the "Left" and "Right" keys. This menu allows you to set the language type, time, etc. of the control unit.

M-PACT plus Air circuit breaker

Control Unit

Overload long-time protection

Overload long-time protection is based on the actual RMS effective current of each phase and neutral line.

Overload long-time protection value setting

The Overload long-time protection is set to:

- Ir : Overload long-time tripping current setting value
- tr : Overload long-time tripping time setting value, at 6Ir

LONG TIME		
SHORT TIME	MODE	TRIP
INST	Ir(*In)	0.2
GF SUM	Ir(A)	640
GF CT	tr(s)	2
GF PREALARM	COOLING	0m
MCR		
HSIOC		
RELT		
NEUTRAL		
IU		
< PROTECTION >		
LONG TIME		

Setting	Unit	Range	Step	Default
Ir	A	(0.2-1) xIn	1A or 0.1xIn	1 xIn
tr	S	0.5-24	0.1	4

Overload long-time protection feature

tr=0.5-24s, step 0.1s

protection feature:

I < 1.05 × Ir: No trip

I > 1.2 × Ir: Tripping

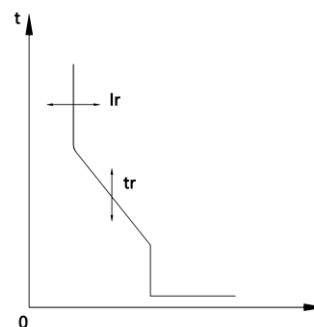

Tr Overload long-time protection time delay is applicable to cold conditions, for phase currents or neutral line currents equal to 6 × Ir.

When the current is greater than Isd or li, the tripping time takes effect according to the short delay and instantaneous protection time.

Long delay minimum trip time 500ms.

Tr(@6×Ir)	0.5s	1s	2s	4s	8s	12s	16s	20s	24s
1.5 × Ir	12.5s	25s	50s	100s	200s	300s	400s	500s	600s
6×Ir	0.5s	1s	2s	4s	8s	12s	16s	20s	24s
7.2×Ir	0.34s	0.69s	1.38s	2.76s	5.52s	8.3s	11s	13.8s	16.6s

M-PACT plus Air circuit breaker

Control Unit

Short circuit delay protection

Short circuit delay protection is based on the true effective current of the phase.

Setting of short-circuit delay protection value

Short circuit delay protection helps to protect equipment from phase to phase short circuits and phase to ground short circuits, with complete selectivity.

It includes two features: timed and inverse timed, depending on the state of the I² t setting.

Short circuit delay tripping protection accuracy: ± 10%.

The running time of short delay protection depends on the tsd time delay. They are suitable for I² T ON or OFF.

Setting	Unit	Range	Step	Default
Isd	A	(1.5~10) × Ir, OFF	1A	1.5×Ir
Tsd (I ² T ON)	s	0.1~0.4	0.1	-
Tsd (I ² T OFF)	s	0~0.4	0.1	0.1

Short circuit delay protection characteristics

I²T ON tripping curve (I < 10Ir),

$$T = (10/N)^2 \times tsd,$$

$$N = I/I_r,$$

$$tsd = 0.1, 0.2, 0.3, 0.4$$

Features	Current multiplier (I/Isd)	Agreed release time
Non action feature	< 0.9	no trip
action feature	> 1.1	tripping
action delay	≥ 1.1	see following table

• I²t ON trip time (I ≥ 10Ir)

Tsd	0.1s	0.2s	0.3s	0.4s
Non action time	> 80ms	> 160ms	> 260ms	> 360ms
Maximum trip time	< 140ms	< 240ms	< 340ms	< 440ms

• I²t OFF trip time

Tsd	0s	0.1s	0.2s	0.3s	0.4s
Non action time	> 20ms	> 80ms	> 160ms	> 260ms	> 360ms
Maximum trip time	< 80ms	< 140ms	< 240ms	< 340ms	< 440ms

LONG TIME		
SHORT TIME	MODE	TRIP
INST	Ir(A)	3200
GF SUM	Isd(*Ir)	1.5
GF CT	Isd(A)	4800
GF PREALARM	tsd(ms)	100
MCR	I2t	OFF
HSIOC		
RELT		
NEUTRAL		
IU		
< PROTECTION >		
SHORT TIME		

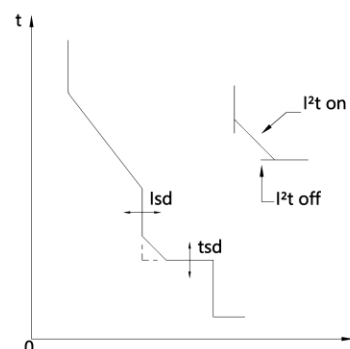

M-PACT plus Air circuit breaker
Control Unit

Short circuit instantaneous protection

Instantaneous protection can prevent equipment from experiencing short circuits between phase lines, between phase lines and neutral lines, and between phase lines and ground. This protection operates with a time limited characteristic. When the set current is exceeded, the product will trip without any other time delay.

LONG TIME		
SHORT TIME		
INST	MODE	TRIP
GF SUM	li(*In)	2
GF CT	li(A)	6400
GF PREALARM		
MCR		
HSIOC		
RELT		
NEUTRAL		
IU		
< PROTECTION >		
INST		

Short circuit instantaneous protection value setting

Setting	Unit	Range	Step	Default
li	-	off /trip	-	trip
li	A	(2~15) ×In	1A	2.0×In

Short circuit instantaneous protection features

$I < 0.9 \times li$: no trip

$I > 1.1 \times li$: tripping

Features	Unit	
Non release time	ms	>20
Maximum release time	ms	≤80

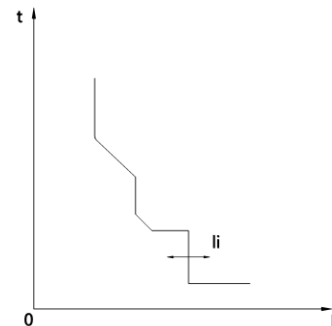

M-PACT plus Air circuit breaker

Control Unit

Ground fault protection, GF SUM

Ground fault protection is based on the true effective current of the phase.

Ground fault protection can prevent phase to ground faults and is suitable for TN-S (three-phase five wire system) systems as well as other grounding systems.

The grounding fault current is calculated or measured based on the configuration of the circuit breaker, as shown in the table below.

Calculation method for ground fault protection

Circuit breaker configuration	I _g (Ground fault current)
3P	I _g =I _A +I _B +I _C
4P	I _g =I _A +I _B +I _C +I _N
3P+N(T)	I _g =I _A +I _B +I _C +I _N (ENCT)
3P/4P(W)	I _g =I _W

LONG TIME		
SHORT TIME		
INST	MODE	OFF
GF SUM		
GF CT	I _g (*I _n)	0.2
GF PREALARM	I _g (A)	640
MCR	t _g (ms)	400
HSIOC	I _{2t}	OFF
RELT		
NEUTRAL		
IU		
< PROTECTION		
GF SUM		

Ground fault protection switch and setting

Setting	Unit	Range	Step	Default	accuracy
I _g Enable	-	off / trip	-	off	
I _g	A	I _g =(0.2-1)I _n	1A	0.2 I _n	±10%

Ground fault protection characteristics

The operation time of ground fault protection depends on the T_g time delay. It suitable for I² T ON or OFF.

t _g	0s	0.1s	0.2s	0.3s	0.4s	Default
I ² T ON	-	0.1s	0.2s	0.3s	0.4s	0.1
I ² T OFF	0s	0.1s	0.2s	0.3s	0.4s	0.1

I²t ON trip time (I < I_n)

$$T = (1/N)^2 * t_g$$

$$N = I / I_n$$

$$t_g = 0.1, 0.2, 0.3, 0.4$$

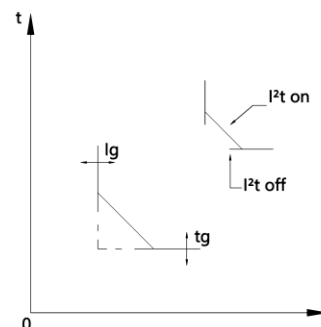

protection features:

I < 0.9 × I_g: no trip

I > 1.1 × I_g: tripping

• I²t ON trip time (I ≥ I_n)

t _g	0.1s	0.2s	0.3s	0.4s
Non trip time	> 80ms	> 160ms	> 260ms	> 360ms
Max. trip time	< 140ms	< 240ms	< 340ms	< 440ms

• I²t OFF trip time

t _g	0	0.1s	0.2s	0.3s	0.4s
Non trip time	> 20ms	> 80ms	> 160ms	> 260ms	> 360ms
Max. trip time	< 80ms	< 140ms	< 240ms	< 340ms	< 440ms

M-PACT plus Air circuit breaker

Control Unit

Ground fault protection, GF CT

Applicable to leakage faults caused by equipment insulation damage or leakage faults caused by human contact with exposed conductive parts, the leakage trip value $I \Delta n$ is directly expressed in amperes and is independent of the rated current of the circuit breaker. The signal acquisition method is zero sequence sampling, which requires an additional rectangular transformer; This type of sampling has high accuracy and sensitivity, and is suitable for protection with small currents. This protection is only applicable to Mpro32/42 control units.

Setting	Unit	Range	Step	Default	Accuracy
Ig Enable	-	Off / Trip	-	off	
Ig Action value	A	$I_g = (0.2-1)I_n$	1A	0.2 I _n	±10%

LONG TIME		
SHORT TIME	MODE	OFF
INST		
GF SUM	$I_g (*I_n)$	0.2
GF CT	$I_g (A)$	640
GF PREALARM	tg(ms)	100
MCR	I _{2t}	OFF
HSIOC		
RELT		
NEUTRAL		
IU		
< PROTECTION >		
GF CT		

The operation time of ground fault protection depends on the Tg time delay. It suitable for I²T ON or OFF.

tg	0s	0.1s	0.2s	0.3s	0.4s	Default
I ² T ON	-	0.1s	0.2s	0.3s	0.4s	0.1
I ² T OFF	0s	0.1s	0.2s	0.3s	0.4s	0.1

I^2t ON trip time ($I < I_n$); $T = (1/N)^2 * tg$,

$N = I/I_n$; $tg = 0.1, 0.2, 0.3, 0.4$

• I²t ON trip time ($I \geq I_n$)

tg	0.1s	0.2s	0.3s	0.4s
Non trip time	> 80ms	> 160ms	> 260ms	> 360ms
Max. trip time	< 140ms	< 240ms	< 340ms	< 440ms

• I²t OFF trip time

tg	0	0.1s	0.2s	0.3s	0.4s
Non trip time	> 20ms	> 80ms	> 160ms	> 260ms	> 360ms
Max. trip time	< 80ms	< 140ms	< 240ms	< 340ms	< 440ms

Protection feature:

$I < 0.9 \times I_g$: non trip

$I > 1.1 \times I_g$: tripping

M-PACT plus Air circuit breaker

Control Unit

Ground fault pre-alarm

The grounding pre-alarm function and grounding protection function are independent of each other and exist simultaneously, with their own independent setting parameters. The action mode of the alarm function is the same as that of the ground fault protection, using the same sensors, curves, and protection time. Grounding fault pre-alarm is based on the total current of each phase line and neutral line, or external transformers, current grounding circuit current transformers connected to the control unit through modules.

Powered by internal CT without the need for external power supply.

LONG TIME		
SHORT TIME	MODE	GF SUM
INST		
GF SUM	ACT PU	
GF CT		120A
GF PREALARM	ACT TIME	
MCR		1.0s
HSIOC	RETURN PU	
RELT		120A
NEUTRAL	RETURN TIME	
IU		1.0s
< PROTECTION >		
GF PREALARM		

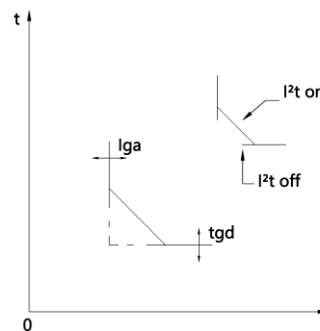

Grounding fault warning setting

Setting	Unit	Range	Step	Setting	Accuracy
Grounding pre alarm mode	-	Off ,GFSUM,GFCT	-	Off	
Grounding and alarm values	A	120-1200A	1A	200A	±10%
Grounding pre alarm time	s	1-10	0.1s	10	> 400ms: ±10% ≤400ms: see I²t OFF,Short delay tripping time
Grounding pre alarm return value	A	120-1200A	1A	120A	±10%
Grounding pre alarm return time	S	1-10	0.1s	10	> 400ms: ±10% ≤400ms: see I²t OFF,Short delay tripping time

Protection feature:

$I < 0.9 \times I_g$: Un-warning

$I > 1.1 \times I_g$: warning

M-PACT plus Air circuit breaker
Control Unit

Neutral line protection (N-phase protection)

In practical applications, the cables and current characteristics used for the neutral phase often differ greatly from those of other three phases, and different protections need to be implemented for the neutral phase according to different application situations. When the neutral line is thin, a semi fixed value method can be used for protection; When the neutral line is the same as others, it can be protected using the method of full set value; When the harmonics in the power grid are relatively heavy, a protection method of 1.6 times the fixed value can be used for protection.

The setting of neutral line protection is only for long delay protection, and other protection settings are the same as those for phase line protection.

LONG TIME		
SHORT TIME		
INST	SWITCH	OFF
GF SUM		
GF CT	N	100%
GF PREALARM		
MCR		
HSIOC		
RELT		
NEUTRAL		
IU		
< PROTECTION		
NEUTRAL		

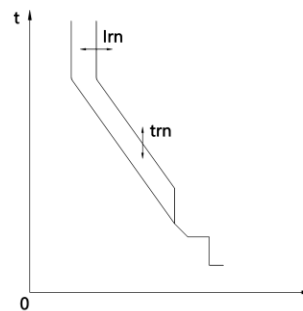

Explanation of M-PACT Neutral Line Protection Corresponding to breaker Types

Item	Breakers	Neutral line protection
1	3PT-3P Breaker	-
2	3P+N-3P Breaker+external neutral line RC	Off, 50%, 100%, 160%
3	4PT-4P Breaker	Off, 50%, 100%, 160%

Neutral line protection (N-phase protection) setting

Setting	Unit	Range	Default
N-phase protection mode	-	Off / Trip	Trip
N-phase action value	A	50%-160%	100%

M-PACT plus Air circuit breaker Control Unit

MCR and HSIOC protection

MCR protection is a closing short circuit protection for the circuit breaker itself; When the fault current exceeds the limit, MCR protection protects the circuit breaker's ability to make connections, preventing the switch from being damaged due to current exceeding the limit of the circuit breaker's ability to make connections. The protection is activated at the moment the circuit breaker is closed (within 120ms); HSIOC protection protects the maximum carrying capacity of the circuit breaker, preventing the switch from carrying current exceeding the level limit breaking capacity, and takes effect 120ms after closing.

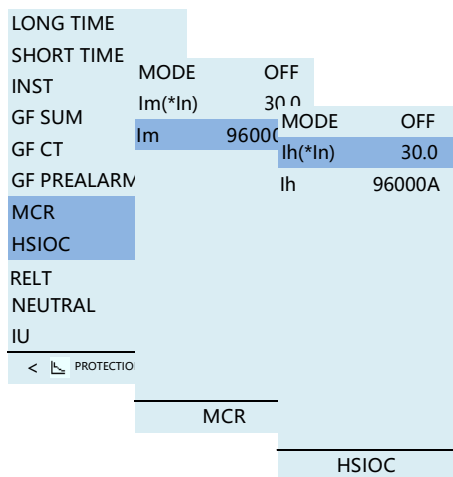

MCR and HSIOC protection parameter settings

Setting	Unit	Range	Default
MCR protection	-	Trip/Off	Trip
MCR action value	A	30In or Icw	30In

Setting	Unit	Range	Default
HSIOC protection	-	Trip/Off	Trip
HSIOC action value	A	30In or Icw	30In

MCR and HSIOC protection feature

Feature	Unit	Default
Non-Trip time	ms	>20
Max. trip time	ms	≤80

Short-circuit Protection temporary reduced (RELT)

When a Short-circuit event takes place, large amount of electrical energy is released that can be hazardous to users in the direct vicinity of such an occurrence. In order to limit the current levels during such events and to reduce their time span, the Mpro control Unit can be equipped with a temporary Reduced Instantaneous Device. The RELT device can be turned ON by accessing input one of the trip unit (1). When the device is switched ON Relay output one (1) changes position and reverts to its standard position when RELT is OFF.

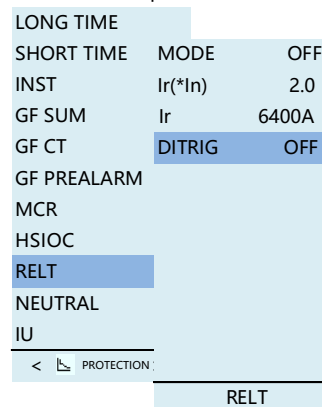

RELT protection parameter settings

Setting	Unit	Range	Step	Default
RELT Enable	-	Off / Trip	-	Off
RELT Value	A	(2~15) In	1A	10In

Trip time

Feature	Unit	Default
Non-trip time	ms	>20
Max. trip time	ms	≤80

RELT Feature:

- $I < 0.9 \times I_{RELT}$: Non-trip
- $I > 1.1 \times I_{RELT}$: tripping

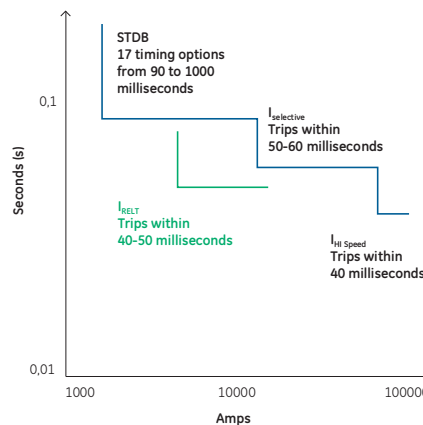

M-PACT plus Air circuit breaker

Control Unit

Current imbalance protection

Current imbalance protection protects against current imbalance between phase and three-phase, and takes protective actions based on the imbalance rate between the three-phase currents. When the execution mode is alarm, its action principle is the same as grounding protection.

Calculation method for imbalance rate:

$$I_{unbal} = \frac{|E_{max}|}{I_{avg}} \times 100\%$$

Iavg: The average RMS value of the three-phase currents Ia, Ib, Ic:

$$I_{avg} = \frac{I_a + I_b + I_c}{3}$$

E_{max}:The maximum difference between each phase current and Iavg.

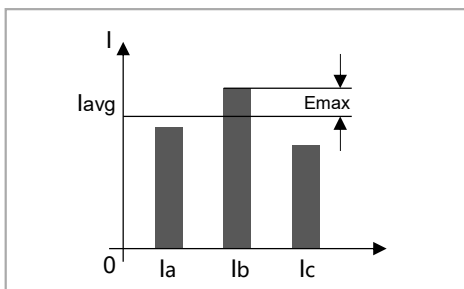

LONG TIME		
SHORT TIME		
INST	MODE	OFF
GF SUM	ACT PU	
GF CT		20%
GF PREALARM	ACT TIME	
MCR		3.0s
HSIOC	RETURN PU	
RELT		20%
NEUTRAL	RETURN TIME	
IU		10.0s
< PROTECTION		
IU		

Current imbalance protection setting

Setting	Unit	Range	Step	Default	Accuracy
Current imbalance mode	-	Off / Trip / Alarm	-	Off	-
Current imbalance action value	%	2%~90%	1%	20%	±10%
Current imbalance time	s	0.1~300s	0.1s	10s	> 400ms: ±10% ≤400ms: 见12t OFF
Return value of current imbalance	%	2%~90%	1%	2%	±10%
Current imbalance return time	s	0.1~300s	0.1s	10s	> 400ms: ±10% ≤400ms: 见12t OFF

M-PACT plus Air circuit breaker

Control Unit

Undervoltage protection

The control unit measures the true effective value of the main circuit voltage. When the three phase to phase voltages (line voltage) or phase to neutral line voltages (phase voltage) are all less than the set value, that is, when the maximum value of the three voltages is less than the undervoltage protection set value, the undervoltage protection will activate; When the maximum value of the three line voltages is greater than the return value, the alarm action returns.

The control unit needs to be powered by an external 24V power supply.

RELT		
NEUTRAL		
IU	MODE	OFF
LOAD MONIT	ACT PU LN	
UV		20V
OV	ACT TIME	
VU		10.0s
UF	RETURN PU LN	
OF		20V
RP	RETURN TIME	
PS		10.0s
< PROTECTIO		
UV		

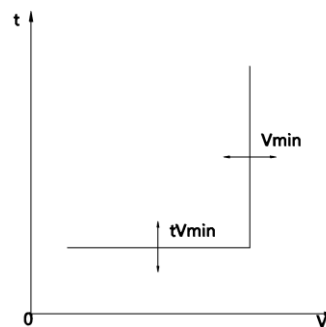

Undervoltage protection setting

Setting	Unit	Range	Step	Default	Accuracy
Undervoltage protection mode	-	Off/ Trip/ Alarm	-	Off	-
Undervoltage protection action value	V	20V ~ 1500V	1V	280V	±5%
Undervoltage protection time	s	0.1~300s	0.1s	10s	> 400ms: ±5% ≤400ms: see I²t OFF
Under voltage protection return value	%	20V ~ 1500V	1V	360V	±5%
Undervoltage protection return time	s	0.1~300s	0.1s	10s	> 400ms: ±5% ≤400ms: see I²t OFF

M-PACT plus Air circuit breaker
Control Unit

Overvoltage protection

The control unit measures the true effective value of the main circuit voltage. When all three phase to phase voltages (line voltage) or phase to neutral line voltages (phase voltage) are greater than the set value, that is, when the minimum value of the three voltages is greater than the overvoltage protection set value, the overvoltage protection will activate; When the minimum value of the three voltages is less than the return value, the alarm action returns. When the minimum line voltage is greater than the action threshold, an alarm or trip delay is triggered. When the action delay time is reached, an alarm or trip

RELT		
NEUTRAL	MODE	OFF
IU	ACT PU LN	
LOAD MONITC		400V
UV	ACT TIME	
OV		10.0s
VU	RETURN PU LN	
UF		220V
OF	RETURN TIME	
RP		10.0s
PS		
< PROTECTION >		
OV		

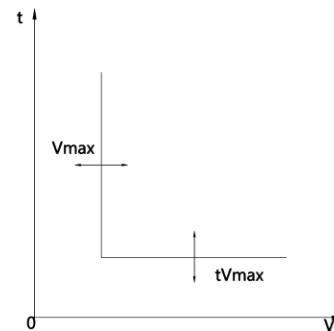

Overvoltage protection setting

Setting	Unit	Range	Step	Default	Accuracy
Overvoltage protection mode	-	Off / Trip / Alarm	-	Off	-
Overvoltage protection action value	V	20V ~ 1500V	1V	460V	±10%
Overvoltage protection time	s	0.1~300s	0.1s	10s	> 400ms: ±10%
Overvoltage protection return value	%	20V ~ 1500V	1V	440V	±10%
Overvoltage protection return time	s	0.1~300s	0.1s	10s	> 400ms: ±10%

M-PACT plus Air circuit breaker

Control Unit

Voltage imbalance protection

Voltage imbalance protection operates based on the imbalance rate between three line voltages. Its operating principle is the same as overvoltage protection.

Calculation method for imbalance rate:

$$U_{unbal} = \frac{|E_{max}|}{U_{avg}} \times 100\%$$

Uavg: The average RMS value of three-phase line voltage

$$U_{avg} = \frac{U_{ab} + U_{ac} + U_{bc}}{3}$$

E_{max}: The maximum difference between each line voltage and the average value.

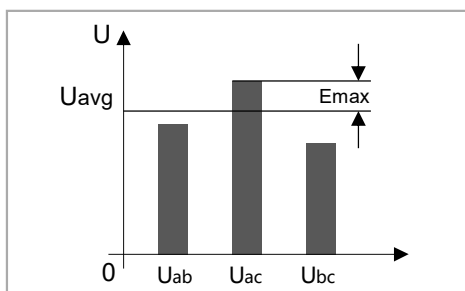

RELT		
NEUTRAL		
IU	MODE	OFF
LOAD MONITOR	ACT PU	
UV		20%
OV	ACT TIME	
VU		10.0s
UF	RETURN PU	
OF		10%
RP	RETURN TIME	
PS		10.0s
< PROTECTION >		
VU		

Voltage imbalance protection setting

Setting	Unit	Range	Step	Default	Accuracy
Voltage imbalance protection mode	-	Off / Trip / Alarm	-	Off	-
Voltage imbalance protection action value	%	2%~90%	1%	20%	±10%
Voltage imbalance protection time	s	0.1~300s	0.1s	10s	> 400ms: ±10% ≤400ms: see I ² t OFF
Voltage imbalance protection return value	%	2%~90%	1%	10%	±10%
Voltage imbalance protection return time	s	0.1~300s	0.1s	10s	> 400ms: ±10% ≤400ms: see I ² t OFF

M-PACT plus Air circuit breaker

Control Unit

Underfrequency protection

The control unit detects the frequency of the system voltage and can provide protection for frequencies that are too high or too low. The operating principles and characteristics of over frequency and under frequency protection are the same as those of over voltage and under voltage protection.

Powered by an external 24V power supply.

RELT		
NEUTRAL		
IU	MODE	OFF
LOAD MONITOR	ACT PU	
UV		45.0HZ
OV	ACT TIME	
VU		10.0s
UF	RETURN PU	
OF		50.0HZ
RP	RETURN TIME	
PS		10.0s
< PROTECTION >		
UF		

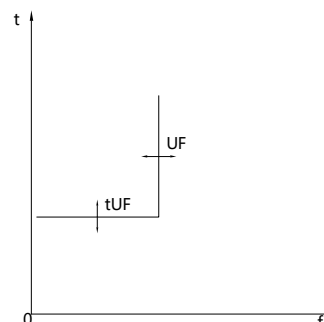

Underfrequency protection setting

Setting	Unit	Range	Step	Default	Accuracy
Underfrequency protection mode	-	Off / Trip / Alarm	-	Off	-
Underfrequency protection action value	Hz	40 ~ 70	0.1Hz	45	±10%
Underfrequency protection time	s	0.1~300s	0.1s	10s	> 400ms: ±10% ≤400ms: see I ² t OFF
Underfrequency protection return value	Hz	40 ~ 70	0.1 Hz	49	±10%
Underfrequency protection return time	s	0.1~300s	0.1s	10s	> 400ms: ±10% ≤400ms: see I ² t OFF

M-PACT plus Air circuit breaker Control Unit

Overfrequency protection

The control unit detects the frequency of the system voltage and can provide protection for frequencies that are too high or too low. The operating principles and characteristics of overlocking and overlocking protection are the same as those of overvoltage and undervoltage protection.

Powered by an external 24V power supply.

RELT	
NEUTRAL	
IU	MODE OFF
LOAD MONITC	ACT PU 55.0HZ
UV	ACT TIME 10.0s
OV	RETURN PU 50.0HZ
VU	RETURN TIME 10.0s
UF	
OF	
RP	
PS	
< PROTECTION >	
过频	

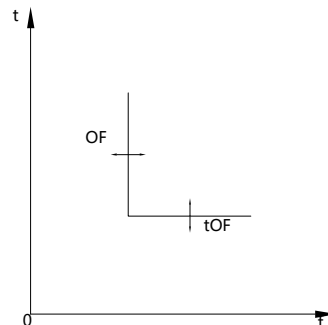

Overfrequency protection setting

Setting	Unit	Range	Step	Default	Accuracy
Overfrequency protection mode	-	Off / Trip / Alarm	-	Off	-
Overfrequency protection action value	Hz	40 ~ 70	0.1 Hz	55	±10%
Overfrequency protection time	s	0.1~300s	0.1s	10s	> 400ms: ±10% ≤400ms: see I ² t OFF
Overfrequency protection return value	Hz	40 ~ 70	0.1 Hz	51	±10%
Overfrequency protection return time	s	0.1~300s	0.1s	10s	> 400ms: ±10% ≤400ms: see I ² t OFF

M-PACT plus Air circuit breaker Control Unit

Power reversal protection

Power reversal protection, also known as reverse active power protection, takes the sum of three-phase active power. When the direction of power flow is opposite to the user set power direction and greater than the set value, the protection is activated. The power direction and power input direction should be set in the "Measurement Meter Settings" menu and must be consistent with the actual application situation. Its operating principle is the same as overvoltage protection.

Powered by an external 24V power supply.

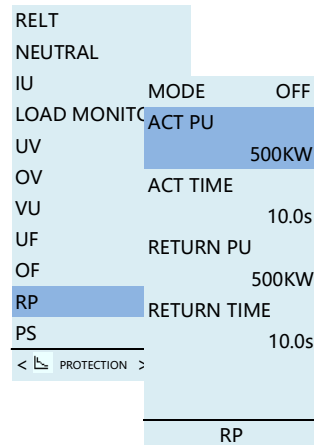

Power reversal protection setting

Setting	Unit	Range	Step	Default	Accuracy
Power reversal protection mode	-	Off / Trip / Alarm	-	Off	-
Power reversal action value	kW	50 ~ 5000	10	55	±10%
Power reversal protection time	s	1 ~ 300s	0.1s	10s	> 400ms: ±10% ≤ 400ms: see I ² t OFF
Power reversal protection return value	kW	50 ~ 5000	10	51	±10%
Power reversal protection return time	s	1 ~ 300s	0.1s	10s	> 400ms: ±10% ≤ 400ms: see I ² t OFF

M-PACT plus Air circuit breaker
Control Unit

Phase sequence protection

The phase sequence detection is taken from the main circuit voltage. When the phase sequence is detected to be in the same direction as the starting value setting, the protection action is activated, and the protection characteristic is instantaneous. When one or more phase voltages are not present, this function automatically exits.

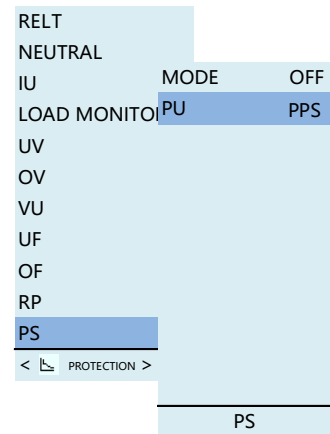

Phase sequence protection setting

Setting	Unit	Range	Step	Default	Accuracy
Phase sequence protection mode	-	Off / Trip / Alarm	-	Off	-
Phase sequence protection action value	-	1-2-3/1-3-2	-	1-2-3	-

M-PACT plus Air circuit breaker Control Unit

Measurement of electrical parameters

Ammeter

The ME control unit provides current measurement function, which can measure the current of each phase, as well as the grounding current, average current, current imbalance, and minimum imbalance.

CURRENT			
VOLTAGE			
POWER		RMS	
PWR FACTOR	I1: 0.00A	IgCT: 0.00A	
FREQUENCY	I2: 0.00A	AVERAGE	
PHASE	I3: 0.00A	I1: 0.00A	
	Ig: 0.00A	I2: 0.00A	
	IgCT: 0.00A	I3: 0.00A	
		MAX UNBALANCE	
	I1: 0.00A	I1: 0%	
	I2: 0.00A	I2: 0%	
	I3: 0.00A	I3: 0%	
< METER >	I3: 0.00A	MAXUNBAL	
	Ig: 0.00A	I1: 100%	
		CURRE I2: 100%	
		I3: 202%	
		CURRENT	

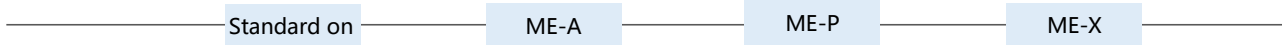

Measurement of electrical parameters

The ME-P and ME-X control unit provides comprehensive electrical parameter measurement functions, allowing customers to browse real-time data of multiple electrical parameters. The menu on the right lists most of the parameter measurement functions. After entering the "Measurement" menu, users can select and browse the corresponding measurement functions.

			RMS	
CURRENT	U12: 0V			
VOLTAGE	U23: 0V			
POWER	U31: 0V			
PWR FACTOR	U1N: 0\	P(KW)		
FREQUENCY	U2N: 0\	P1: 0		
PHASE	U3N: 0\	P2: 0		
		P3: 0		PF
	U12: 0\	Ptot: 0		PF1: 0.0
	U23: 0\	Q(KV)PF2: 0.0		
	U31: 0\	Q1: 0		PF3: 0.0
		Q2: 0		PF: 0.0
< METER >		VOLTA Q3: 0		
		Qtot: 0		
		S(KV)		
		POWER		
				PWR FACTOR

It can measure the maximum, minimum, average, and voltage imbalance of the displayed voltage. Users can choose to view line voltage or phase voltage type according to their needs.

The power measurement function for supply and demand includes effective power P (kW), apparent power Q (KVA), and reactive power S (KVAR).

The Mpro control unit provides advanced measurement functions such as power factor, frequency, phase, etc.

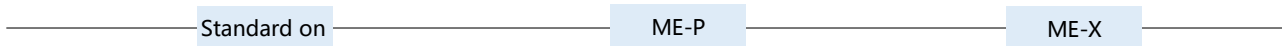

Voltage measurement and external additional power supply

It is necessary to measure the voltage of the three-phase and neutral lines using the above-mentioned comprehensive electrical parameter measurement function, and feedback this data to the control unit. The type P/ type X control unit provides standard voltage measurement and transmission modules for safe and reliable measurement of voltage parameters by the control unit.

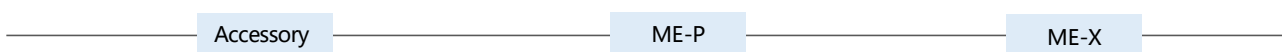

M-PACT plus Air circuit breaker
Control Unit

External additional power supply and reset settings

External additional power supply

The application of advanced functions of the control unit requires an external 24V DC power supply for continuous power supply. The auxiliary power supply unit module can convert the corresponding grid voltage to 24V DC, and this module can also set parameters for the control unit when the load current is low (<20%).

In addition, the testing module can also be used to temporarily supply power to the control unit.

The test module is equipped with a built-in 24V DC battery pack module.



Reset settings

Usually, circuit breakers trip due to circuit faults. Users need to carefully check the specific cause of the fault in the lower level circuit, confirm the cause of the fault and eliminate it before allowing the circuit breaker to be reset and reconnected. The Mpro electronic control unit provides a comprehensive fault trip recording function to help customers analyze the cause, level, size, and location of faults, and take corresponding measures.



In order to track the occurrence of faults, the control unit provides a trip reset function, usually manual reset. But customers can also set the trip reset to manual or automatic reset through the selection knob on the panel. If remote reset of the circuit breaker is required, the selection button on the panel can be set to manual reset, and a remote reset coil can be equipped to achieve the function of tripping and resetting the circuit breaker.



M-PACT plus Air circuit breaker Control Unit

Communication function

Communication function

The optional communication function of the control unit has full duplex Modbus RTU communication function. The communication function requires an external 24V DC power supply, and for Modbus, a power capacity of no less than 90mA is required.

The control unit complies with the Modbus communication protocol and a 2-wire RS485 interface, and can set baud rates of 4800, 9600, and 19200.

The control unit with communication function can simultaneously set parameters through panel or communication, including overcurrent protection setting and protection relay setting.



NFC function

All ME control units are equipped with NFC near-field communication function, using short-range wireless communication method, integrating RFID and interconnection technology, supporting the use of compatible devices to quickly and easily identify and exchange data with M-PACT plus air circuit breakers at close range.

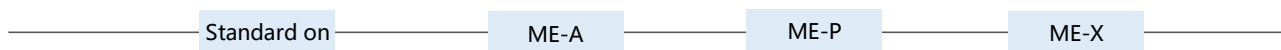

Bluetooth function

The ME-X type control unit is equipped with standard Bluetooth data connectivity, allowing it to identify and read data from circuit breakers within a 10-meter range. Additionally, by using the ME APP, users can view the status of the circuit breaker and achieve remote control. Remote control requires connection to the trip and close coil.



M-PACT plus Air circuit breaker
Control Unit

Measurement Function

The M-PACT plus air circuit breaker has evolved into an intelligent circuit breaker that integrates protection and power management. The X-type control unit, while providing multiple power protection and measurement functions, adopts power metering standards in the design and selection of circuit breaker components and manufacturing processes. This enhances the protection accuracy of the circuit breaker, meeting the power management requirements of customers in most applications.

The X-type control unit achieves a measurement accuracy of $\pm 1\%$ for current, $\pm 1\%$ for voltage, and $\pm 1\%$ for power (within the range of 0.2-1In and Ue).



Waveform Capture and Analysis Function

When a fault current occurs, accurately recording information about the fault is very important. The ME-X control unit provides waveform capture functionality, which can clearly record fault events. This feature can record and save the fault current waveform.

Users can record this waveform to the client through the software module, reset the control unit, and clear the waveform capture record in preparation for the next recording. The captured waveform can be analyzed using the backend management suite.



M-PACT plus Air circuit breaker

Control Unit

Test Kit

The test module is used to verify whether the coordination between breaker and the control unit is effective. This module is equipped with 24V DC battery pack, which can be used to power the control unit when there is no load current in the distribution network. There is a test port on the control unit's panel for connection with the test module.

The ME management software toolkit allows users to monitor, configure, and even test trip curves using a laptop.

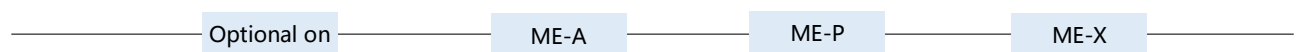

Protection relay: relay input/output

Relay input DI

Provide two relay input functions. Each relay input can choose OFF/TRIP/RELT (one of three options), configured as follows:

DI	Function	Description
Setting option	OFF	OFF
	TRIP	After inputting the signal, the circuit breaker outputs a trip pulse to the magnetic flux coil, causing the circuit breaker to trip
	RELT	After inputting the signal, enable the RELT setting value. (RELT must be set to remote)

Relay output DO

Provide 2 relay output functions. The first group has been automatically assigned to circuit breaker closing, and the second group has been automatically assigned to circuit breaker opening. Each relay output can choose EVENT/ALARM/TRIP (one out of three), and there are multiple options in the sub menu for each function, as shown in the table below

DO	Function	Description
Setting option	EVENT	Action event Lower level menu: NONE (no output), REMOTE-OFF (remote opening), REMOTE-ON (remote closing), RELT-ON (dual short circuit protection)
	ALARM	Send an alarm command, and the circuit breaker will execute the alarm when receiving it Submenus: ALL (All), SELF-TEST (Self check Test), CONT (Electrical Contact Life), PS (Phase Sequence), OF (Overfrequency Alarm), UF (Underfrequency Alarm), RP (Power Reversal Alarm), VU (Voltage Imbalance Alarm), OV (Overvoltage Alarm), UV (Undervoltage Alarm), IU (Current Imbalance Alarm), N-ST (N-Phase Short Circuit Short Delay Alarm), N-LT (N-Phase Overload Long Time Alarm), GFCT (Ground Leakage Alarm), GFSUM (Ground Fault Alarm), GA (Ground Alarm), LT (Overload Long Time Alarm), NONE (No Output)
	TRIP	Send output command, circuit breaker receives trip pulse, magnetic flux trips, circuit breaker trips ALL (All), PS (Phase Sequence), OF (Overfrequency Protection), UF (Underfrequency Protection), RP (Reverse Power Protection), VU (Voltage Imbalance Protection), OV (Overvoltage Protection), UV (Undervoltage Protection), IU (Current Imbalance Protection), N-I (N-Phase Short Circuit Transient Protection), N-ST (N-Phase Short Circuit Short Delay Protection), N-LT (N-Phase Overload Long Time Protection), RELT (Double Short Circuit Protection), HSIOC (Restricted Short Circuit Transient Protection), MCR (Closed Short Circuit Protection), GF CT (Ground Leakage Protection), GF SUM (Ground Fault Protection), I (Short Circuit Transient Protection), ST (Short circuit short delay protection), LT (Overload long Time protection), NONE (No output)

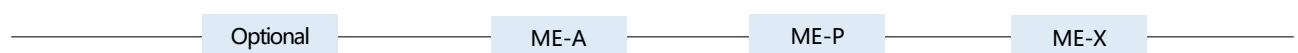

Note: A03 and A06 without relay input/output configuration.

M-PACT plus Air circuit breaker

Breaker Accessories

M-PACT plus Use & Operation

M-PACT plus is operated by a stored energy mechanism that can be charged either manually or electrically.

To charge manually a handle (1) is used to 'load' the springs in the mechanism, 10 pumping movements being required.

During charging a spring status indicator (2) clearly indicates if the breaker is CHARGED (Red), CHARGING (Yellow), or

DIS-CHARGED (Green). After charging is complete, the ready to close indicator (3) indicates that the device can be turned ON and OFF by the ON/OFF buttons (4 & 5) on the breaker front facia. A padlocking mechanism (6) is present for up to three locks that can prevent un-authorized pushbutton operation.

An electrical charging mechanism negates the need for loading the springs manually and allows remotely located pushbuttons to be used to switch ON & OFF

The contact position indicator (7) on the Breaker front provides the user with the correct status of the breaker be OFF or ON.

This indicator is linked to the mechanism and contact system in a manner that allows the device to be used as a Disconnecter and to meet the 'Positive Contact Indication' requirements.

The Breaker Mechanism is of the trip free type and has an integrated anti-pumping system. The front facia also includes room for an optional key padlock to off position (8) that prevents the breaker from being closed if the key is not inserted and the keylock turned to 'close'. The interlock device allows a maximum of 5 keylocks to be placed.

The breaker can be equipped with up to four factory or field mountable releases, 1 x closing coil and a combination of shunt and undervoltage releases being possible. The presence of these releases is made visible on the facia by the use of 4 indicator windows (9).

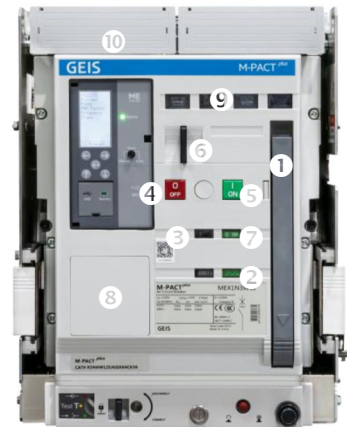

Front panel of circuit breaker

M-PACT plus are available in two patterns, Fixed and Draw-out. A Fixed device is bolted to a substructure or wall and the power connections are directly fixed to the breaker. A draw-out device has a cassette that is mounted and connected separately.

A fixed breaker requires the connection and fixation to be removed to replace the breaker.

A breaker in draw-out pattern is supplied as a moving portion, that easily slides in and out of the separately fixed and connected cassette.

Each standard device is supplied with 4 NO and 4 NC auxiliary contacts. A front panel with door escutcheon seal and a IP20 terminal strip or plug 10 with 39 connection points to wire out accessories.

M-PACT plus Air circuit breaker
Breaker Accessories

M-PACT plus Use & Operation

Draw-out Pattern Cassette



To dismantle a M-PACT plus in the Fixed pattern, it is required that the power supply is turned off and the connections are removed. A breaker in the Draw-out pattern can be quickly and efficiently removed from the system without disconnecting the Power Supply or removing the connections. The Draw-out system allows easy and simple access to the breaker and its components and enables the user to fully disconnect the power from the installation for maintenance purposes.

Access to the breaker being required for periodic checks and some very limited maintenance allowing the device to be used over its full life span. The cassette (1) is mounted and connected separately and the M-PACT plus is supplied as a moving portion that is easily inserted into the cassette. A racking handle (2) is stored within an aperture in the cassette. After removing and unfolding the racking handle and disengaging the blocking mechanism (3), the handle can be inserted into the 'racking' aperture. By rotating the racking handle clockwise to move the moving portion inwards (connect) and anticlockwise to move outwards, the breaker can be racked into one of three positions:

CONNECTED: Breaker and cassette are fully operational all contacts are connected.

TEST: The maincontacts are not connected.The Auxiliary contacts are connected.

DISCONNECTED: The main and auxiliary contacts are not connected. The breaker is still inside the cassette.

A Position indicator (4) provides a positive mechanical indication of the indicated Connected, Test and Disconnected positions. Each M-PACT plus cassette has integrated Safety Shutters that automatically isolate the user from live parts when the moving portion is in disconnect or test position.

Multiple accessories as carriage position switches, mechanical interlocks, a miss-insertion device, IP54 front protection covers, and key lock devices are available (please refer to the relevant sections in this chapter).

Each standard cassette is supplied with standard main connections, racking handle, safety shutters and a IP20 terminal socket system with 39 connection points to wire out accessories.

M-PACT plus Air circuit breaker
Breaker Accessories

Electrical Charging mechanism (motor)

Electrical Operation of Breaker

In order to charge the stored energy mechanism electrically a motor mechanism is available. The design allows factory or field mounting and is available for the full range of M-PACT plus breakers. It is easily fitted with just three bolts.

When the circuit breaker is opened, the mechanism automatically recharges the springs and prepares the breaker for an almost instantaneous reclosure should the need arise.

High speed recharging ensures that the springs are fully charged within four seconds. A "Spring Charged" contact that indicates the status of this device is always present. A 2nd 'ready to close' contact is available that indicates that the springs have been recharged and that the breaker can be closed.

The device is available in multiple AC & DC voltages and can be used in a operating frequency of up to two operations per minute. it has a life span equivalent to that of the breaker without maintenance. To switch the M-PACT plus ON & OFF remotely a Closing Coil and Shunt Release is also necessary.



Connections

The Charging mechanism connection points can be found on terminal A of both the Fixed Pattern & Draw-out Breaker types.

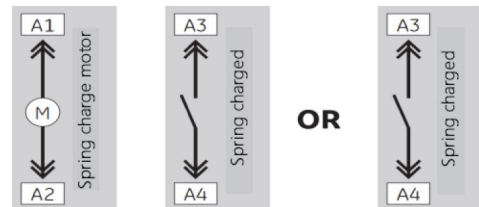

Electrical characteristics	Frame 1	Frame 2 & 3
	Motor Operator	Motor Operator
Control Voltage	Power Consumption	
24-30V DC	300W	480W
110-130V DC		
220 - 250V DC		
110-130V AC	350VA	560VA
220-240V AC		
380-400V AC		

M-PACT plus Air circuit breaker
Breaker Accessories

Closing Coil of Breaker

Closing Coil

To switch the Circuit Breaker ON remotely a closing coil is available that when energized releases the spring charged closing mechanism.

The device is available as a factory mounted component or as a field mountable device. It is an extremely easy-to-fit, clip-on unit, with simple plug-in connectors.

The coils have a life span equivalent to that of the full breaker life with maintenance.

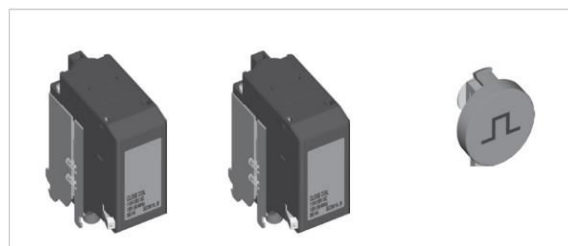

Connections

The Closing coils & Command closing coils connection points can be found on terminal A of both the Fixed Pattern & Draw-out Breaker types.

Electrical characteristics

AC	DC	Power Consumption
-	24V	350 VA Inrush
110-130V	110-130V	
220-240V	220-240V	
380-415V	-	

M-PACT plus Air circuit breaker

Breaker Accessories

Shunt, Undervoltage Releases and remote reset Coil

Shunt release

A device designed to switch the Circuit Breaker OFF remotely. When energized a Shunt Release instantaneously activates the circuit breaker mechanism thus ensuring a rapid disconnection of the main contacts (50msec).

All M-PACT plus Shunt Release are suitable for a continuous power supply and are designed to be used as a closure prevention device when energized. Two Shunt Releases can be mounted in each Power Circuit Breaker.

The device is available as a factory mounted component or as a field mountable device. It is an extremely easy-to-fit, clip-on unit, with simple plug-in connectors.

The individual devices have a wide voltage range, thus limiting the number of devices needed and have a life span equivalent to that of the full breaker life span without maintenance.



Remote reset coil

The remote reset coil accessory is mounted on the PMU base (Protection & Measurement Unit) and used for resetting the Trip unit (Manual mode) from remote location in the event of Trip using a shunt trip coil. For resetting remotely using this accessory the knob on the front of the trip unit should be pointing to manual. The device is available as a factory mounted component or as a field mountable device. It is an extremely easy-to-fit, clip-on unit, with simple plug-in connectors.

Electrical characteristic

AC	DC	Power Consumption
--	24V	350VA / 350W Inrush
110-130V	110-130V	
220-240V	220-240V	
380-415V	--	60 VA / 50W Holding

Undervoltage Release

A device designed to open the breaker contacts and to prevent the breaker from closing when in a 'No volt' condition. On a de-energization the Undervoltage release activates the circuit breaker mechanism and ensures a rapid disconnection of the main contacts (50 Milliseconds). When not re-energized in accordance to the conditions stated in the IEC 60947 the device prevents the Power Circuit Breaker from closing. The M-PACT plus Undervoltage releases are designed to react within a pre-defined Voltage band, only reacting when the voltage supplying drops below the limits of this band. To prevent nuisance tripping due to short power interruptions or 'Brown Outs' the device has a built in delay of 50 Milliseconds. Two Undervoltage Releases can be mounted in each Power Circuit Breaker.

The device is available as a factory mounted component or as a field mountable device. It is an extremely easy-to-fit, clip-on unit, with simple plug-in connectors.

The individual devices have a wide voltage range, thus limiting the number of devices needed and can be used in an operating frequency of up to two operations per minute.



Connection

The connection points of both releases can be found on terminal A of both the Fixed Pattern & Draw-out Breaker types. it is possible to mount a total of three of these releases, the scheme below shows all possible combination

Frame 1&2&3

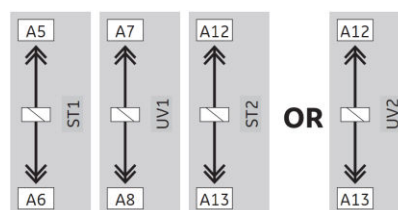

M-PACT plus Air circuit breaker
Breaker Accessories

Time Delay Module

The de-energizing operation of the Undervoltage release can be delayed. This optional, externally mounted module has an adjustable time delay of zero to three seconds. The device can be implemented to prevent undesired Breaker tripping due to momentary voltage interruptions and is connected in series with the Undervoltage release.



Optionally, the M-PACT plus can be supplied with a three phase plus neutral Undervoltage protection device that can provide a power interruption alarm and/or initiate a breaker 'trip'.

Electrical characteristics

AC	DC	Power Consumption
110-130V	--	350VA Inrush
--	110-130V	
220-240V	220-240V	60 VA Holding
380-415V	--	

M-PACT plus Air circuit breaker

Breaker Accessories

Auxiliary Contacts

Auxiliary contacts are designed to indicate the position of the Circuit Breaker main contacts. Each M-PACT plus is supplied with a standard package of 3 Normally open (NO) and 3 normally closed (NC) contacts that operate simultaneously with the breakers main contacts. Optionally other packages are available that can be used to increase the number of available contacts by replacing the standard auxiliary contact block.

Connection

The connection points of the auxiliary contacts can be found on the two terminals (A & B) of both the Fixed Pattern & Draw-out Breaker types.

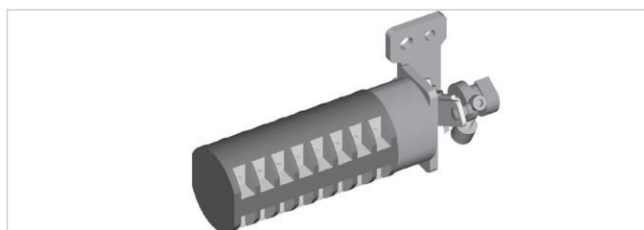

Auxiliary Contact packages options

- power rated contacts 4 NO & 4 NC⁽¹⁾
- power rated contacts 8 NO & 8 NC
- power rated contacts 4 NO & 4 NC plus
- Signal rated contacts 4 NO & 4 NC⁽²⁾

The devices are available as factory mounted components or as a field mountable device. Auxiliary contact packages are easy-to-fit, and have simple plug-in connectors.

Electrical characteristics Auxiliary Contacts Power Rated types

AC		DC	
Voltage	Current	Voltage	Current
110-130V	AC21 - 15A	24V	DC21 -15A
	AC23 - 10A		
220-240V	AC21 - 10A	110-130V ⁽³⁾	DC21 -10A
	AC23 - 5A		
380-440V	AC21 - 5A	250V ⁽⁴⁾	DC21 -5A
	AC23 - 2.5A		

Minimum Operating Current 0,16A at 8V DC

Signal Rated, gold plated contact types

AC		DC	
Voltage	Current	Voltage	Current
250V	AC21-0.1A	8-30V	DC21-0.1A

Minimum Operating Current 1 mA at 5V DC

(1) stand configuration is 4NO & 4NC power rated auxiliary contact. A03 and A06 types do not support other package options

(2) applicable for Frame 1&2&3 (see wiring diagram section for full schematics)

(3) Three contacts in series

(4) Six contacts in series

M-PACT plus Air circuit breaker

Breaker Accessories

Bell Alarm & Cassette position indication

Alarm Contacts

When an Circuit Breaker has tripped due to a fault detected by the trip unit, a Bell Alarm Changeover contact is available to indicate this by switching mechanically

The device is available as a factory mounted component or as a field mountable device. The Bell Alarm contact is easy-to-fit, and has simple plug-in connectors. The contact can only be used when the breaker is adjusted to "manual reset" .

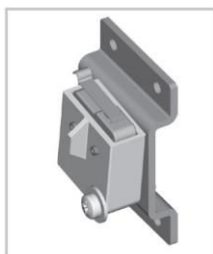

Connection

The connection points of the Bell Alarm contact can be found on terminal A of both the Fixed Pattern & Draw-out Breaker types.

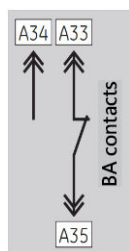

Electrical characteristics Bell Alarm Contact

AC		DC	
Voltage	Current	Voltage	Current
250V	AC21-6A	125V	DC21-0.4A
		250V	DC21-0.2A

Minimum Operating Current 0,16A at 5V DC

Cassette Position Indication Contacts

A breaker in draw-out mode has a cassette that is used for mounting and connecting. The breaker, in its moving portion mode, can be inserted into the cassette and by use of the racking handle and it can be moved to one of three positions

Connected, Test, Disconnected or Withdrawn

To indicate in which position the Breaker is located within the Cassette position is Indication contacts are available. The disconnected position is only being indicated when minimum isolating distances between contacts on both the main and auxiliary circuits have been achieved. The devices are available in two packages with 1 or 2 changeover contacts per position.

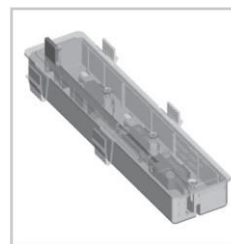

Commonly referred to as Carriage switches they are available as a factory mounted component or as a field mountable device.

The device is located in the left side of the cassette substructure and can be accessed and connected directly.

Electrical characteristics Position Indication Contacts

AC		DC	
Voltage	Current	Voltage	Current
250V	AC21-10A	125V	DC21-0.5A
		250V	DC21-0.25A

M-PACT plus Air circuit breaker
Breaker Accessories

Spring Charged & Ready to close contacts

A breaker with electrical charging mechanism can be optionally equipped with one or two indication contacts. The first the Spring Charged Contact simply does as indicated and is supplied with the standard Motor Operating Mechanism. The second, the ready to close indication, optionally replaces the Spring Charged Contact. It only moves position when the following conditions are met:

- > The circuit breaker is open
- > The closing springs are charged
- > The circuit breaker is not locked/interlocked in open position
- > There is no standing opening order
- > There is no standing opening order

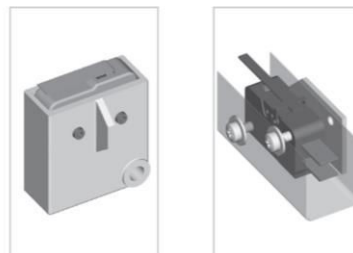

Both contacts are available in a 1NO configuration.

Connection

The connection points of these contacts can be found on terminal A of both the Fixed Pattern & Draw-out Breaker types.

Electrical characteristics Power Rated types

AC		DC	
Voltage	Current	Voltage	Current
250V	AC21-6A	125V	DC21-0.4A
		250V	DC21-0.2A

Minimum Operating Current 0.16A at 5V D

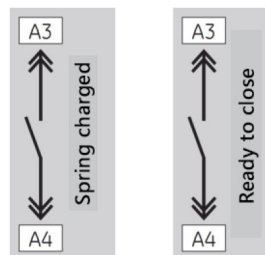

Electrical characteristics Signal Rated types ⁽¹⁾

AC		DC	
Voltage	Current	Voltage	Current
125V	AC21-0.1A	8-30V	DC21-0.1A

Minimum Operating Current 1mA at 5V DC

(1) Spring Charged contact NOT available in signal rated version

M-PACT plus Air circuit breaker

Breaker Accessories

Mechanical Interlocking of Multiple Breakers

Mechanically Interlocked Breakers

Many Low Voltage Installations have multiple power sources that are used in many different configurations. The power sources are required to supply the installation simultaneously, alternatively or in a certain logical combinations of both.

The M-PACT plus can be used to protect these Power supplies and be electrically and mechanically interlocked to provide the necessary logic.

The mechanical interlocks are available for fixed and draw out circuit breakers, enabling the direct interlocking of the breakers, mounted on the left.



The device has two parts; the first a kit for use can only be factory mounted with the breaker in fixed pattern or the cassette when a draw-out pattern is required. Two or more specially designed field mountable flexible cables available in lengths of 1,0; 1,6; 2,0; 2,5; 3,0;3,5 and 4,0 meter s being the second.

Any combination mode (fixed or draw-out), current rating, number of poles or Frame size can be interlocked. The interlocking systems are available in one configuration for 2 breakers and in three others for 3 breakers.

Two Breaker Interlock

Interlock type A in which only one of the two breakers (B1 or B2) can be switched ON. Each breaker must be equipped with a factory mounted interlock type A. Two flexible cables are needed.



Three Breaker Interlock type B

Interlock type B in which only one of the three breakers (B1, B2 or B3) can be switched ON. Each breaker must be equipped with a factory mounted interlock type B. Six flexible cables are needed.

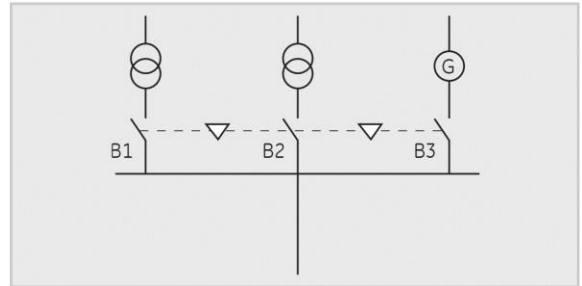

Three Breaker Interlock type C

Interlock type C in which one or two of the three breakers canbe switched ON in accordance with the inserted diagram. Each breaker must be equipped with a factory mounted interlock type C. Six cables are needed.

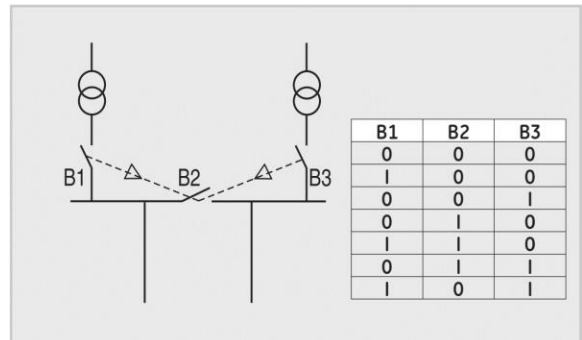

Three Breaker Interlock type D

Interlock type D in which one or two of the three breakers can be switched ON in accordance with the inserted diagram. Breakers B1 & B3 must be equipped with a factory mounted interlock type A and B2 with a interlock type D. Four cables are needed.

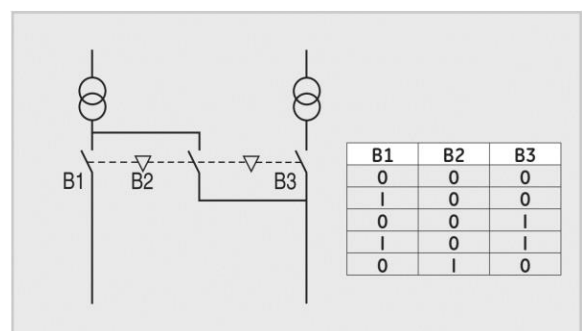

M-PACT plus Air circuit breaker
Breaker Accessories

**Locking provisions for Breaker and Cassette Door-Interlock systems;
 Mis insertion device**

Standard Padlocking Facilities Breaker & Cassette

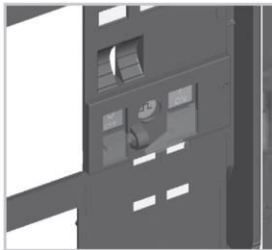

M-PACT plus are supplied with two standard padlocking devices. The breaker in Fixed and Draw out pattern have a padlocking facility for one padlock of 5-8mm allowing the breaker to be locked in its OFF position.

Cassette Key lock facilities

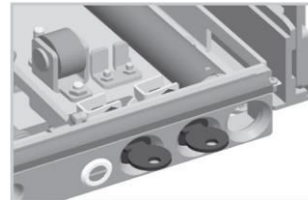

The Cassette of a Circuit breaker can be equipped with key lock. The key lock system encompasses a device fitted to the cassette allowing the locks and the separate locks to be fitted. The device ensures that a draw-out circuit breaker cannot be moved from the TEST or DISCONNECT position unless the key has been inserted and secured within the lock.

Facia Pushbutton Padlocking Facilities

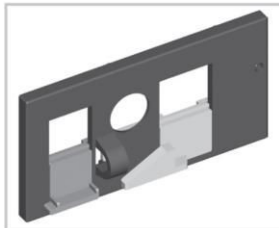

To prevent un-authorized access to both the ON and OFF push buttons on the breakers front facia, a padlockable push button cover can be fixed to the breaker front facia. 1 padlock of 5-8mm can be used.

Mis Insertion Device

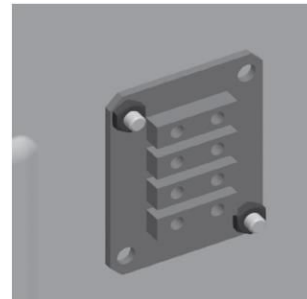

By incorporating this optional security interlock device into the draw-out cassette, an inadvertent insertion of an incorrect rated moving portion is prevented. Before using the interlocking system, the misinsertion logic needs to be set on both the breaker and the device.

Breaker Key lock facilities

A Circuit breaker can be equipped with key locks. The key lock system encompasses a device fitted in the front facia allowing the locks to be fitted and the separate locks. These devices ensure that a circuit breaker cannot be closed unless the key has been inserted and secured within the lock.



For frame 1&2&3, a breaker can be equipped with up to 4 key locks on the facia.

M-PACT plus Air circuit breaker
Breaker Accessories

Installation Accessories

Operations Counter

A simple and easy to install mechanical device that displays an accurate and cumulative record of the number of closing operation of the Circuit Breaker in which it is installed.

The mechanical and electrical life span of the breaker can be extended by limited periodic maintenance. The counter contains information that can assist in determining when.

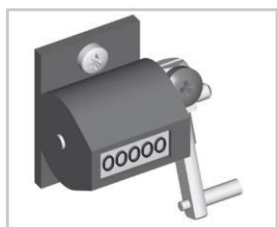

Sensors, Rogowski coils

If the ME Electronic Trip Unit is configured to allow Ground fault protection. For a three pole circuit breaker and 3 phase 5 wire system an external Neutral sensor can be required. Rogowski coils for this application are available as separate items and are supplied with a mounting kit. For the correct sensor choice and application details see Control unit chapter of this catalogue.



Contact Wear Indicator

A second simple and easy to install mechanical device that can be used to ascertain when breaker maintenance is needed. Mounted above the contacts of a breaker in draw-out mode it allows the user to physically see the contacts and contains markers to determine their wear.

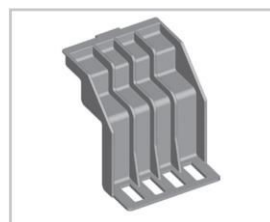

Current Sensors, CT

If the ME Electronic Trip Unit is configured to allow Earth/ Ground fault protection an external Neutral sensor can be required. In most standard applications a Rogowski coil suffices, however in some cases other Sensors are needed. Current Transformer are used for 'Source Ground' return ground fault applications.

If combinations of ground fault options as UEF, REF & SEF are required multiple sensors could be required.

Current Transformers for these application are available as separate item and are supplied with a mounting kit and an extra interposing Current Transformer needed in some specific cases. For the correct sensor(s) choice and application details see Control unit chapter of this catalogue.

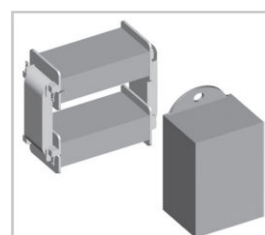

M-PACT plus Air circuit breaker
Breaker Accessories

Installation Accessories

Wall Mounting Brackets

M-PACT plus are designed to be mounted within a frame inside a low voltage Distribution or Control panel. In some cases, specifically when the front connection option is used, wall mounting can be more expedient.

For this purpose, wall mounting brackets are available for the breakers in Fixed Pattern, Frame 1 and 2.

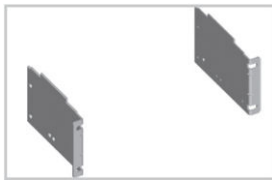

IP54 Cover

All Circuit Breakers are supplied with a door flange/door frame that allows the user to finish the door cut-out professionally, simultaneously providing a protection degree of IP31. If a higher protection degree is required, an additional cover is available allowing IP54

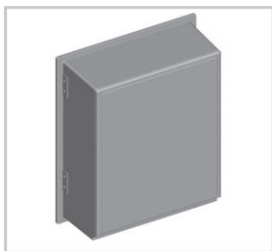

Terminal Block

Breakers in Fixed Pattern, cassettes and breakers in Draw-out mode is always supplied with an auxiliary connection block suitable for 39 connection points (terminal A). When the number of factories installed accessories exceeds the available number of connection points needed a 2nd connection block is automatically added (terminal B). For cases where the accessories are mounted in the field, separate auxiliary connection block is available; two types suited for the breakers in fixed pattern (39 or 78 pole) and one for breakers in draw out mode (adding 39 poles).



Hoisting/Lifting accessories

All M-PACT plus protection devices are equipped with a set of hoisting eyes. To use these hoisting eyes with standard lifting equipment specifically designed adaptors are available.

GLB1 is available for use with Frame 1&2 breakers up to 4000A and GLB2 is for larger Frame3 breaker with rating up to 6400A

M-PACT plus Air circuit breaker
Breaker Accessories

M-PACT plus Circuit Breaker Usage and Operation

Earthing device

To allow either the incoming cables or the busbar to be safely held at earthed potential and locked during system maintenance, all M-PACT plus can be fitted with an earthing device.

The device is available as a separate field mountable accessory and has a Short-circuit rating equal to the short time withstand (Icw) of the breaker.



Spare parts for general use

The M-PACT plus Circuit breaker uses components that are designed to last the full life span of the device. However, certain components can be damaged or break during operational use. For these specific cases, the following spare parts are available:

- Cassette: moving portion Racking Handle (A)
- Shutters (B)
- Breaker (C): Front cover

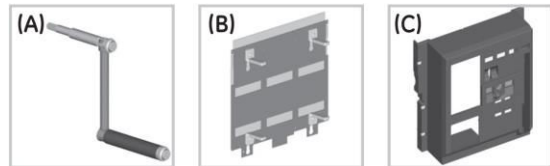

Spare part for maintenance purposes

M-PACT plus Breakers require periodic maintenance. Here, in some cases certain components critical to the devices functionality could need replacement.

Please contact our service department for specialist assistance in establishing which components need replacement and the physical replacement activities. The following items are available:

- Arc Chutes (A)
- Fixed arcing Contacts (B)
- Cassette cluster contacts (C)
- Pliers to remove Cassette cluster contacts (D)

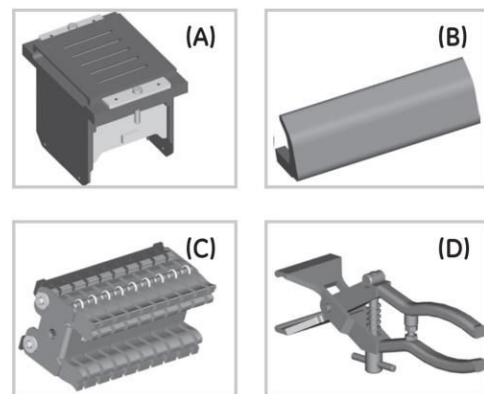

M-PACT plus Air circuit breaker

Breaker Accessories

M-PACT plus Internal Accessories

Motor Operators and closing coil	Voltage	Cat. No.	Ref.No.	Cat. No.	Ref.No.	
			Motor Operator Type Frame 1		Motor Operator Type Frame 2 3	
	24-30V DC	MOP30DP1	MPPA0001	MOP30DP23	MPPA0101	
	110-130V DC	MOP130DP1	MPPA0002	MOP130DP23	MPPA0102	
	220V DC	MOP220DP1	MPPA0003	MOP220DP23	MPPA0103	
	110-130V AC	MOP130AP1	MPPA0004	MOP130AP23	MPPA0104	
	220-250V AC	MOP250AP1	MPPA0005	MOP250AP23	MPPA0105	
	380-415V AC	MOP415AP1	MPPA0006	MOP415AP23	MPPA0106	
Closing coil						
	24V DC	CC24DP	MPPA0201			
	110-130V AC/DC	CC130ADP	MPPA0202			
	220-240V AC/DC	CC240ADP	MPPA0203			
	250-277V AC	CC277AP	MPPA0204			
	380-415V AC	CC415AP	MPPA0205			
Releases						
	Voltage	Cat. No.	Ref.No.	Cat. No.	Ref.No.	
			Undervoltage		Shunt	
	24V DC	UV24DP	MPPA0401	ST24DP	MPPA0301	
	110-130V AC/DC	UV130ADP	MPPA0402	ST130ADP	MPPA0302	
	220-240V AC/DC	UV240ADP	MPPA0403	ST240ADP	MPPA0303	
	250-277V AC	UV277AP	MPPA0404	ST277AP	MPPA0304	
	380-415V AC	UV415AP	MPPA0405	ST415AP	MPPA0305	
Remote reset coil						
	Voltage	Cat. No.	Ref.No.			
	24V DC	CCRR24DP	MPPA0501			
	110-130V AC/DC	CCRR130ADP	MPPA0502			
	220-240V AC/DC	CCRR240ADP	MPPA0503			
Auxiliary Contacts						
	Contact type	Cat. No.	Ref.No.			
	auxiliary contact frame 1/2/3					
	Power Rated 4NO & 4NC	PAUX44P	MPPA0504			
	Power Rated 8NO & 8NC ⁽¹⁾	PAUX88P	MPPA0505			
	Power Rated 4NO & 4NC + signal rated 4NO & 4NC ⁽¹⁾	PSAUX44P	MPPA0506			
Bell Alarm Contacts						
	Contact type	Cat. No.	Ref.No.			
				Bell Alarm Contact Type1/2/3		
	Power rated 1 changeover	PBAT11P	MPPA0507			
signal rated 1 changeover	SBAT11P	MPPA0508				
Indication Contacts						
	Contact type	Cat. No.	Ref.No.	Cat. No.	Ref.No.	
			Power rated		Signal rated	
	breaker RTC indicator 1NO	PRTC10P	MPPA0509	SRTC10P	MPPA0511	
breaker RTC indicator 1NC	PRTC01P	MPPA0510	SRTC01P	MPPA0512		
Position Indication Contacts Cassette						
	Cat. No.	Ref.No.	Cat. No.	Ref.No.		
			Cassette Indication Frame 1		Cassette Indication Frame 2/3	
	1 Changeover power rated 1NO/1NC	PCSWFF11P1	MPPA0513	PCSWFF11P23	MPPA0516	
	2 Changeover Power rated 2NO/2NC	PCSWFF22P1	MPPA0514	PCSWFF22P23	MPPA0517	
2 Changeover Power rated 1NO/1NC & Signal rated 1NO/1NC	PSCSWFF11P1	MPPA0515	PSCSWFF11P23	MPPA0518		

note: A03, A06 control unit only support 4NO + 4NC power contact

M-PACT plus Air circuit breaker
Breaker Accessories

M-PACT plus Internal Accessories



Internal Accessories - Field mountable
 Maximum amount of installable internal accessories

Motor Operator Frame 1 or 2	Closing Coil	Undervoltage Release*	Shunt Release	Auxiliary Contacts Power NO + NC	Auxiliary Contacts signal NO + NC	Bell Alarm contacts	Breaker ready to close indication	Breaker Spring Charged Position Indication Contacts (per Pos.)	Breaker Spring Charged indication	Earthing Device	Locking Mechanis Breaker
1	1	2	1	8	0	1	1	0	2	1	1
1	1	1	2	8	0	1	1	0	2	1	1
1	1	1	0	8	0	1	1	0	2	1	1
1	1	0	1	8	0	1	1	0	2	1	1
1	1	2	1	8	0	1	0	1	2	1	1
1	1	1	2	8	0	1	0	1	2	1	1
1	1	1	0	8	0	1	0	1	2	1	1
1	1	0	1	8	0	1	0	1	2	1	1
1	1	2	1	4	4	1	1	0	2	1	1
1	1	1	2	4	4	1	1	0	2	1	1
1	1	1	0	4	4	1	1	0	2	1	1
1	1	0	1	4	4	1	1	0	2	1	1
1	1	2	1	4	4	1	0	1	2	1	1
1	1	1	2	4	4	1	0	1	2	1	1
1	1	1	0	4	4	1	0	1	2	1	1
1	1	0	1	4	4	1	0	1	2	1	1
1	1	2	1	4	0	2	0	1	2	1	1
1	1	1	2	4	0	2	0	1	2	1	1
1	1	1	0	4	0	2	0	1	2	1	1
1	1	0	1	4	0	2	0	1	2	1	1

*TDM module (Time delay module) is mounted externally to the breaker

M-PACT plus Air circuit breaker
Breaker Accessories

M-PACT plus Internal Accessories

Mechanical safety lock ⁽¹⁾		Description	Type	Cat.No.	Ref.No.
	Frame 1/2/3	mounted on breaker padlocking ⁽¹⁾	Lock A	PT32412	MPPA0601
			Lock B	PT33221	MPPA0602
			Lock C	PT12123	MPPA0603
			Lock D	PT32312	MPPA0604
			Lock E	PT22131	MPPA0605
			facia allow 1 to 4 Locks to be placed		
<hr/>					
Operation counter		Description	Cat.No.	Ref.No.	
	Counter; number of Operations		MOCP	MPPA0607	
	<hr/>				

(1) The mechanism position lock includes a mechanism, lock core, and key. Users need to select the model based on the type of lock core. This position lock is configured for a single circuit breaker. If interlocking is required, each circuit breaker must be configured accordingly.

M-PACT plus Air circuit breaker
Breaker Accessories

Install accessories separately from the circuit breaker and require on-site installation by the user

mechanism interlocking		Description			Cat.No.	Ref.No.	Cat.No.	Ref.No.	Ref.No.
		Interlocking configuration			Fixed breaker frame 1/2/3		Draw-out breaker	Frame 1/2	Frame 3
Type	Breaker 1	Breaker 2	Breaker 3						
A	OFF	OFF		1 set per breaker		1 set per breaker			
	ON	OFF		2WC13PFP123	MPPA0701	2WC13PWP12/2WC13PWP3		MPPA0702	MPPA0703
	OFF	ON							
B	OFF	OFF	OFF	1 set per breaker		1 set per breaker			
	ON	OFF	OFF	B13WC13PFP123	MPPA0704	B13WC13PWP12/B13WC13PWP3		MPPA0705	MPPA0706
	OFF	ON	OFF						
C	OFF	OFF	ON	1 set per breaker		1 set per breaker			
	OFF	ON	OFF	C23WC13PFP123	MPPA0707	C23WC13PWP12/C23WC13PWP3		MPPA0708	MPPA0709
	ON	ON	OFF						
D	OFF	OFF	ON	1 set each for breaker1 and 3		1 set each for breaker1 and 3			
	ON	OFF	OFF	2WC13PFP123	MPPA0710	2WC13PWP12/2WC13PWP3		MPPA0712	MPPA0713
	OFF	OFF	ON						
	ON	OFF	ON	1 set for breaker 2		1 set for breaker 2			
	OFF	ON	OFF	DWC13FDTP123	MPPA0711	DWC13WDTP12/DWC13WDTP3		MPPA0714	MPPA0715



Field mountable cables for interlocking of breakers ⁽¹⁾	Type	Description	Description	Cat.No.	Ref.No.
	interlocking type	Interlocking configuration			
	A	1 cable per breaker, choose length as indicated	Cable length 1m	100BCMCIP	MPPA0716
	B	2 cables per breaker, choose length as indicated	Cable length 1.5 m	150BCMCIP	MPPA0717
	C	2 cables per breaker, choose length as indicated	Cable length 2 m	200BCMCIP	MPPA0718
	D	Brk's 1 and 3: 1 cable per breaker, choose length as indicated Brk. 2: 2 cables per breaker, choose length as indicated	Cable length 2.5 m	250BCMCIP	MPPA0719
			Cable length 3 m	300BCMCIP	MPPA0720
			Cable length 3.5 m	350BCMCIP	MPPA0721
			Cable length 4 m	400BCMCIP	MPPA0722

M-PACT plus Air circuit breaker
Breaker Accessories

Install accessories separately from the circuit breaker and require on-site installation by the user

Time delay module for UVR release TDM ⁽¹⁾	Voltage	Cat.No.	Ref.No.
	110-130V DC	UVTD130DP	MPPA0801
	220-240V DC	UVTD240DP	MPPA0802
	110-130V AC	UVTD130AP	MPPA0803
	220-240V AC	UVTD240AP	MPPA0804
	250-277V AC	UVTD277AP	MPPA0805
	380-415V AC	UVTD415AP	MPPA0806

ME- Accessories	Voltage	Description	Cat.No.	Ref.No.
	Voltage measurement module 690V		MEPT690	MPPA0807
	Voltage measurement module 800V	Each phase of the circuit breaker must be equipped with a voltage measurement module ⁽²⁾	MEPT800	MPPA0808
	Voltage measurement module 1500V		MEPT1500	MPPA0809
	Test/battery module		XTUTK20	MPPA0810
	Communication module Modbus		MEC2R	MPPA0812

(1) External circuit breaker accessory, DIN rail mounting method, used in conjunction with internal accessory undervoltage release

(2) When the control unit requires a voltage measurement display function, this external voltage measurement module is necessary and this is shown as a spare part.

M-PACT plus Air circuit breaker

Breaker Accessories

M-PACT plus Internal Accessories

Operation accessories	Description	Cat.No.	Ref.No.		
	Front Fascia of Breaker				
	Padlocking device for Pushbuttons Frame 1/2/3	PLDP	MPPA0813		
	Operation Indicators				
	Contact Wear Indicator Frame 1/2/3	CWIDP	MPPA0814		
	Cassette				
	Mis insertion device Frame 1/2/3	ACBMIDP	MPPA0815		
<hr/>					
Door Flanges	Description	Cat.No.	Ref.No.		
	Door Flange fixed frame 1/2/3 ⁽¹⁾	FDFP123	MPPA0816		
	Door Flange draw-out frame 1/2 ⁽¹⁾	WDFP12	MPPA0817		
	Door Flange draw-out frame 3 ⁽¹⁾	WDFP3	MPPA0818		
	Door Escutcheon IP54				
<hr/>					
Phase separators ⁽²⁾	Description	Cat.No.	Ref.No.		
	Fixed	Frame 1	FPSBP1	MPPA0820	Single sheet ⁽²⁾
		Frame 2	FPSBP2	MPPA0821	Single sheet ⁽²⁾
		Frame 3	FPSBP3	MPPA0822	Single sheet ⁽²⁾
	Draw-out	Frame 1/Frame 2	WPSBP12	MPPA0823	Single sheet ⁽²⁾
		Frame 3	WPSBP3	MPPA0824	Single sheet ⁽²⁾
<hr/>					
Extended Phase separators					
	Fixed	Frame 2	FPSBP2E	MPPA0825	Single sheet ⁽²⁾
		Frame 3	FPSBP3E	MPPA0826	Single sheet ⁽²⁾
<hr/>					
Top air barrier for fixed breaker	Applicable for voltage over 690V				
	metal with insulation coating	Frame 2	GF2ARCC3F_ST	MPPA0827	
	metal with insulation coating	Frame 3	GF3ARCC3F_ST	MPPA0828	
	High performance plastic type	Frame 2	GF2ARCC3F	MPPA0829	
	High performance plastic type	Frame 3	GF3ARCC3F	MPPA0830	

(1) This attachment is the standard configuration for the circuit breaker, and this is shown as spare parts.

(2) phase separators, each 3-pole circuit breaker is equipped with a quantity of 2, and each 4-pole circuit breaker is equipped with a quantity of 3.

M-PACT plus Air circuit breaker
Breaker Accessories

Sensors for ME Trip Units



Rated current (A)	Frame 1		Frame 2		Frame 3	
	Cat.No.	Ref.No.	Cat.No.	Ref.No.	Cat.No.	Ref.No.
400A	ME1NRCP04	MPPA0840	ME2NRCP04	MPPA0848		
630A	ME1NRCP06	MPPA0841	ME2NRCP06	MPPA0849		
800A	ME1NRCP08	MPPA0842	ME2NRCP08	MPPA0850		
1000A	ME1NRCP10	MPPA0843	ME2NRCP10	MPPA0851		
1250A	M1ENRCP12	MPPA0844	ME2NRCP12	MPPA0852		
1600A	ME1NRCP16	MPPA0845	ME2NRCP16	MPPA0853		
2000A	ME1NRCP20	MPPA0846	ME2NRCP20	MPPA0854		
2500A	ME1NRCP25	MPPA0847	ME2NRCP25	MPPA0855		
3200A			ME2NRCP32	MPPA0856	ME3NRCP32	MPPA0858
4000A			ME2NRCP40	MPPA0857	ME3NRCP40	MPPA0859
5000A					ME3NRCP50	MPPA0860
6400A					ME3NRCP64	MPPA0861

- For use with Ground fault Residual (sum) protection
- Rogowski coils



Rated current (A)	Frame 1		Frame 2		Frame 3	
	Cat.No.	Ref.No.	Cat.No.	Ref.No.	Cat.No.	Ref.No.
400A	ME1NCTP04	MPPA0862	ME2NCTP04	MPPA0870		
630A	ME1NCTP06	MPPA0863	ME2NCTP06	MPPA0871		
800A	ME1NCTP08	MPPA0864	ME2NCTP08	MPPA0872		
1000A	ME1NCTP10	MPPA0865	ME2NCTP10	MPPA0873		
1250A	M1ENCTP12	MPPA0866	ME2NCTP12	MPPA0874		
1600A	ME1NCTP16	MPPA0867	ME2NCTP16	MPPA0875		
2000A	ME1NCTP20	MPPA0868	ME2NCTP20	MPPA0876		
2500A	ME1NCTP25	MPPA0869	ME2NCTP25	MPPA0877		
3200A			ME2NCTP32	MPPA0878	ME3NCTP32	MPPA0880
4000A			ME2NCTP40	MPPA0879	ME3NCTP40	MPPA0881
5000A					ME3NCTP50	MPPA0882
6400A					ME3NCTP64	MPPA0883

For use with Ground fault protection, Source Ground Return method Earth leg Current Transformers
 Kit includes 1 Current Transformer. An interposing current transformer is also required
 (supplied with Trip Unit)

Application Guide

Handling, Mounting and Connecting

Clearance distances

A modern circuit breaker is designed to interrupt high Short-circuit currents in a very limited time frame. In doing so the breaker vents gas and a limited amount of conductive fragments.

M-PACT plus Low-voltage Circuit Breakers have been designed to limit the venting phenomenon to a minimum, but certain clearances do need to be taken into account as indicated in the front and side views.

The maintenance of the fixed pattern devices requires access to the contacts and the removal of the Arc Chutes. Certain distance needs to be left above the breaker to allow for this as indicated in the front and side views.

Minimum Clearance distances on Fixed Pattern breaker from housing to:

	Metal Parts	Insulated parts
A ⁽¹⁾	160	160
B1	30	30
B2	30	30

Minimum Clearance distances from Draw-out cassette housing to:

	Metal Parts	Insulated parts
A	0	0
B1	30	30
B2	30	30

(1) Dimension allows for field Arc Chute replacements

M-PACT plus Application Instructions for Wind Turbine at AC1140V and Above:

- 1) For wind power generation applications at AC1140V and above, the low-voltage switchgear or transformer substation where the circuit breaker is located must be partitioned according to *form 4b* of the "IEC 7251.12 Low-voltage Switchgear and Controlgear Assemblies (Part 2: Power Switchgear and Controlgear Assemblies)".
- 2) In applications of wind power generation at AC1140V and above, phase separators must be installed on the circuit breaker or isolating switch.
- 3) In applications of wind power generation at AC1140V and above, the copper busbar connecting the circuit breaker inside the switchgear must be fitted with heat shrink sleeves.
- 4) Operating conditions with a frequency lower than 50Hz will reduce the short-circuit breaking capacity of the circuit breaker.

Handling

M-PACT plus Frame 1/2/3 Breakers in the fixed pattern & draw-out portion have two retractable lifting eyes. One of these is located on the breaker right hand side and a 2nd on the left (see sketch).

The cassettes have four re-enforced tilting points with M10 screw thread.

Recommended Connection Cross sections

The adjacent table indicates the recommended bus bar dimensions to be used in connecting the M-PACT plus Circuit Breaker. The current ratings of the devices with these recommended bus bar connection sizes are indicated on page below.

Frame 1 & 2 & 3

Side view of fixed/draw-out pattern

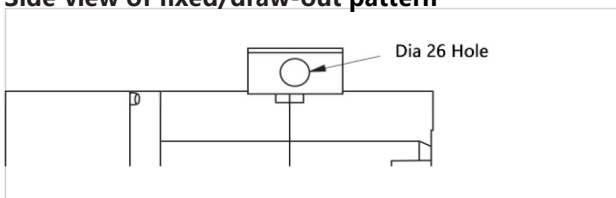

Front View Fixed or Draw-out Pattern

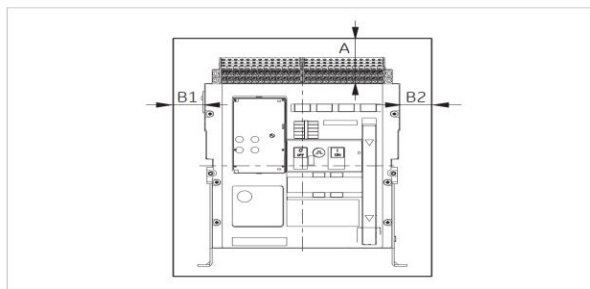

Front View Fixed or Draw-out Pattern

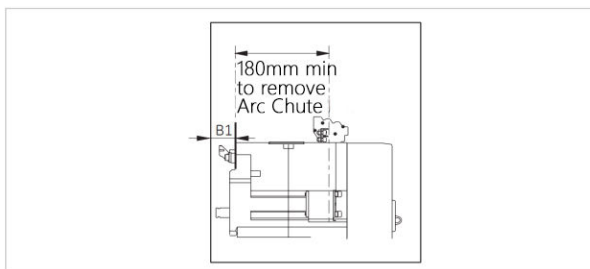

In (A)	Breaker type	Recommended Copper Bus Bar sizes
400	MEX1, MEX2	1 x 40 x 10 or 1 x 80 x 5 or 2 x 40 x 5
		1 x 50 x 10 or 1 x 100 x 5 or 2 x 50 x 5
630	MEX1, MEX2	1 x 50 x 10 or 1 x 100 x 5 or 2 x 50 x 5
		1 x 50 x 10 or 1 x 100 x 5 or 2 x 50 x 5
1000	MEX1, MEX2	1 x 60 x 10 or 2 x 60 x 5
		2 x 40 x 10 or 2 x 80 x 5
1250	MEX1, MEX2	2 x 40 x 10 or 2 x 80 x 5
		2 x 50 x 10 or 2 x 100 x 5
1600	MEX1, MEX2	2 x 50 x 10 or 2 x 100 x 5
		3 x 50 x 10 or 3 x 100 x 5
2000	MEX1, MEX2	3 x 50 x 10 or 3 x 100 x 5
		4 x 50 x 10 or 4 x 100 x 5
2500	MEX1, MEX2	4 x 50 x 10 or 4 x 100 x 5
		4 x 100 x 10
3200	MEX2, MEX3	4 x 100 x 10
		4 x 100 x 10 Plus 1 x 100 x 5
4000	MEX2	4 x 100 x 10 Plus 1 x 100 x 5
		4 x 100 x 10
4000	MEX3	4 x 100 x 10
		5 x 120 x 10 or 6 x 100 x 10
5000	MEX3	5 x 120 x 10 or 6 x 100 x 10
		7 x 120 x 10 or 8 x 100 x 10
6400	MEX3	7 x 120 x 10 or 8 x 100 x 10
		8 x 100 x 10

Note: For Frames 2 4000A and 3@ 6400A, when applied in horizontal wiring, it is recommended to either increase the cross-section of the connecting busbar, enhance cooling measures, or derate the usage.

M-PACT plus Air circuit breaker

Application Guide

Connecting

Frame 1

Fixed pattern

N type 400-1600A Rear Horizontal

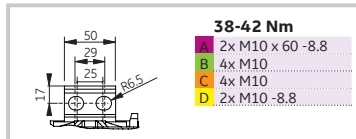

Fixed pattern

400-2500A Rear Vertical

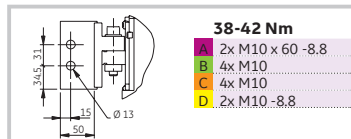

Draw out pattern

400-2500A Rear Horizontal or Vertical

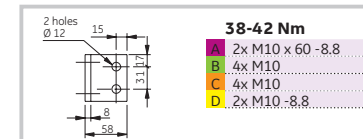

Fixed pattern

S&H type 400-1600A Rear Horizontal

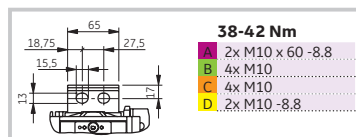

Fixed pattern

2000-2500A Rear Horizontal

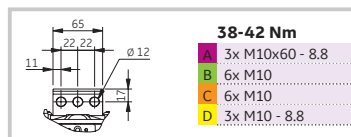

Frame 2

Fixed pattern

400-4000A Rear Horizontal or Vertical

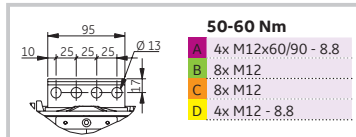

Draw out pattern (1)

400-3200A Rear Horizontal or Vertical

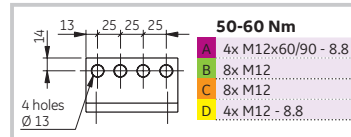

Draw out pattern

4000A Rear Vertical only

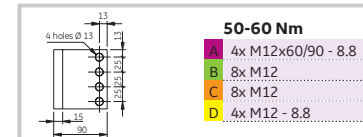

Frame 3

Fixed pattern

4000-6400A Rear Horizontal

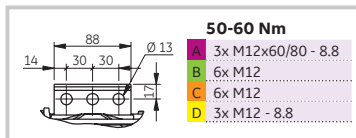

Draw out pattern (2)

4000-5000A Rear Horizontal or 4000-6400A Rear Vertical

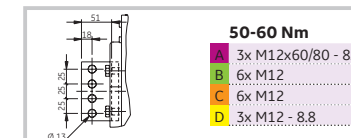

Fixed pattern

5000-6400A Rear Vertical

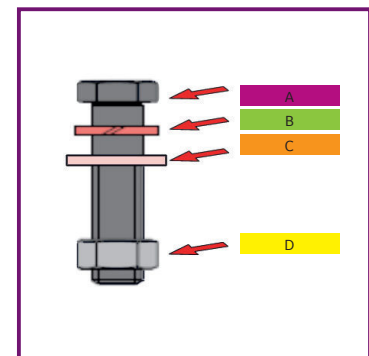
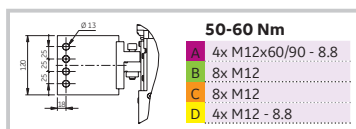

Note: (1) For Frames 2 4000A and 3@ 6400A, when applied in horizontal wiring, it is recommended to either increase the cross-section of the connecting busbar, enhance cooling measures, or derate the usage.

(2) For draw out pattern frame 3, each pole has 2 busbars

Application Guide

Heat Dissipation, Watt loss & Current Ratings at temperatures >50°C

Standards

The standard for low voltage equipment is defined in the EN 60439-1, the EN 50298 and the IEC 60890. These provide a theoretical method to calculate the temperature rise within an enclosure. The main element in these calculations is the power dissipation of the equipment installed. By totalizing this value for all the installed devices, connections, cables and busbars it is possible to calculate the temperature rise within the enclosure. For normal applications a temperature rise within the enclosure of 50 Kelvin is assumed.

Use

An enclosure manufacturer can provide the exact data on the allowable power dissipation within a certain enclosure. The values depend on the enclosure type, the ventilation it offers and where the components are located within this enclosure.

M-PACT plus Circuit breakers

The devices have been designed to offer the lowest, feasible heat dissipation value and the highest possible current ratings when enclosed. The tables here indicate the heat dissipation values and current ratings at temperatures within the direct vicinity of the breaker in free air. The values apply for breakers used with rear connections and the preferred vertical busbars. The recommended connection cross sections and busbar sizes can be found on above page.

Breaker frame type	Frame	In (A)	Power loss at In per pole (W)	Temperature in the direct environment				
				≤50°C	55°C	60°C	65°C	70°C
Maximum user Current Ie in A Vertical connection mode: Fixed pattern								
MEX1	1	400	2,29	400	400	400	400	400
MEX2	2	400	1,66	400	400	400	400	400
MEX1	1	630	5,68	630	630	630	630	630
MEX2	2	630	4,13	630	630	630	630	630
MEX1	1	800	9,15	800	800	800	800	800
MEX2	2	800	6,66	800	800	800	800	800
MEX1	1	1000	14,3	1000	1000	1000	1000	1000
MEX2	2	1000	10,4	1000	1000	1000	1000	1000
MEX1	1	1250	22,3	1250	1250	1250	1250	1250
MEX2	2	1250	16,3	1250	1250	1250	1250	1250
MEX1	1	1600	36,6	1600	1600	1600	1600	1600
MEX2	2	1600	26,6	1600	1600	1600	1600	1600
MEX1	1	2000	57,2	2000	2000	2000	2000	2000
MEX2	2	2000	41,6	2000	2000	2000	2000	2000
MEX1	1	2500	90,3	2500	2375	2250	2190	2125
MEX2	2	2500	65,0	2500	2500	2500	2500	2500
MEX2	2	3200	106	3200	3200	3200	3150	3100
MEX3	3	3200	66,6	3200	3200	3200	3200	3200
MEX2	2	4000	166	4000	3750	3600	3500	3400
MEX3	3	4000	104	4000	4000	4000	4000	4000
MEX3	3	5000	163	5000	5000	5000	4900	4800
MEX3	3	6400	266	6400	6300	6200	6100	6000

Maximum user Current Ie in A Vertical connection mode: Draw-out types								
MEX1	1	400	4,78	400	400	400	400	400
MEX2	2	400	3,74	400	400	400	400	400
MEX1	1	630	11,9	630	630	630	630	630
MEX2	2	630	9,29	630	630	630	630	630
MEX1	1	800	19,1	800	800	800	800	800
MEX2	2	800	15,0	800	800	800	800	800
MEX1	1	1000	29,9	1000	1000	1000	1000	1000
MEX2	2	1000	23,4	1000	1000	1000	1000	1000
MEX1	1	1250	46,7	1250	1250	1250	1250	1250
MEX2	2	1250	36,6	1250	1250	1250	1250	1250
MEX1	1	1600	76,5	1600	1600	1600	1600	1600
MEX2	2	1600	59,9	1600	1600	1600	1600	1600
MEX1	1	2000	120	2000	2000	2000	2000	2000
MEX2	2	2000	93,6	2000	2000	2000	2000	2000
MEX1	1	2500	187,2	2500	2315	2250	2190	2125
MEX2	2	2500	146	2500	2500	2500	2500	2500
MEX2	2	3200	240	3200	3200	3200	3100	3000
MEX3	3	3200	106	3200	3200	3200	3200	3200
MEX2	2	4000	374	4000	3700	3600	3500	3400
MEX3	3	4000	166	4000	4000	4000	4000	4000
MEX3	3	5000	260	5000	5000	5000	4900	4800
MEX3	3	6400	426	6400	6300	6200	6100	6000

Application Guide

Heat Dissipation, Watt loss & Current Ratings at temperatures > 50°C

M-PACT plus circuit breaker

Customers can also choose to connect the busbar in either a rear horizontal wiring or front wiring configuration. The table below lists the power dissipation per pole and the derating of the rated current of the circuit breaker at different ambient temperatures. This table is based on the busbar connection being in a rear horizontal wiring or front wiring configuration. For the recommended cross-sectional area and contact area of the busbar connection, please refer to page 66 of this chapter.

Breaker frame type	Frame	In (A)	Power loss at In per pole (W)	Temperature in the direct environment				
				≤50°C	55°C	60°C	65°C	70°C
				Maximum user Current Ie in A Vertical connection mode: Fixed pattern				
MEX1	1	400	2,29	400	400	400	400	400
MEX2	2	400	1,66	400	400	400	400	400
MEX1	1	630	5,68	630	630	630	630	630
MEX2	2	630	4,13	630	630	630	630	630
MEX1	1	800	9,15	800	800	800	800	800
MEX2	2	800	6,66	800	800	800	800	800
MEX1	1	1000	14,3	1000	1000	1000	1000	1000
MEX2	2	1000	10,4	1000	1000	1000	1000	1000
MEX1	1	1250	22,3	1250	1250	1250	1250	1250
MEX2	2	1250	16,3	1250	1250	1250	1250	1250
MEX1	1	1600	36,6	1600	1600	1600	1600	1600
MEX2	2	1600	26,6	1600	1600	1600	1600	1600
MEX1	1	2000	57,2	2000	2000	2000	2000	2000
MEX2	2	2000	41,6	2000	2000	2000	2000	2000
MEX1	1	2500	89,4	2500	2315	2125	2000	2000
MEX2	2	2500	65,0	2500	2500	2500	2500	2500
MEX2	2	3200	106	3200	3200	3100	3050	3000
MEX3	3	3200	66,6	3200	3200	3200	3200	3200
MEX2	2	4000	(1)	(1)	(1)	(1)	(1)	(1)
MEX3	3	4000	104	4000	4000	4000	4000	4000
MEX3	3	5000	163	5000	5000	5000	4875	4750
MEX3	3	6400	(1)	(1)	(1)	(1)	(1)	(1)

				Maximum user Current Ie in A Vertical connection mode: Draw-out types				
MEX1	1	400	4,8	400	400	400	400	400
MEX2	2	400	3,74	400	400	400	400	400
MEX1	1	630	11,9	630	630	630	630	630
MEX2	2	630	9,3	630	630	630	630	630
MEX1	1	800	19,1	800	800	800	800	800
MEX2	2	800	15,0	800	800	800	800	800
MEX1	1	1000	29,9	1000	1000	1000	1000	1000
MEX2	2	1000	23,4	1000	1000	1000	1000	1000
MEX1	1	1250	47	1250	1250	1250	1250	1250
MEX2	2	1250	36,6	1250	1250	1250	1250	1250
MEX1	1	1600	77	1600	1600	1600	1600	1600
MEX2	2	1600	60	1600	1600	1600	1600	1600
MEX1	1	2000	120	2000	2000	2000	2000	2000
MEX2	2	2000	94	2000	2000	2000	2000	2000
MEX1	1	2500	186,4	2500	2315	2125	2000	2000
MEX2	2	2500	146	2500	2500	2500	2500	2500
MEX2	2	3200	240	3200	3200	3200	3200	2900
MEX3	3	3200	106	3200	3200	3200	3200	3200
MEX2	2	4000	(1)	(1)	(1)	(1)	(1)	(1)
MEX3	3	4000	166	4000	4000	4000	4000	4000
MEX3	3	5000	260	5000	5000	5000	4850	4700
MEX3	3	6400	(1)	(1)	(1)	(1)	(1)	(1)

For products with this rated current level, it is recommended to use vertical terminals for connection. When applied to horizontal terminal, it is advisable to increase the cross-section of the busbar, enhance the cooling method, or use it with reduced capacity.

M-PACT plus Air circuit breaker

Application Guide

Protection of standard Circuits

Protection devices as the M-PACT plus breaker are used in a wide variety of environments to protect conductors, equipment and devices in low voltage distribution circuits. To use this product to its full potential it is necessary to verify that it functions correctly in the environment in which it is used, and that it meets the Electromechanical requirements of the circuit it protect.

Environment

M-PACT plus will function well in almost any industrial environment and fully complies with the environmental requirements of the relevant EN 60 947-2 standard. For conditions other than the above mentioned, please refer to content of this section.

Maximum Short-Circuit Current

Each protective device must be capable of interrupting the maximum Short-circuit current at the point where it is installed. The interruption ratings (Breaking Capacities) of the M-PACT plus circuit breaker can be found in parameter data in this chapter.

Design Current of a circuit

In certain short-circuit events, due to the high system impedance of the circuit, weakest value of short-circuit current will be generated. In this situation, the circuit breaker must also effectively detect this low-current short-circuit fault and reliably interrupt the fault before the electrical equipment or bus cable reaches its short-circuit capacity.

Weakest Short-circuit current in a circuit

The equipment and devices in an electrical circuit determine its current load or design current Ib. A circuit breaker's overload or Ir setting is normally adjusted to a value equal to the design current.

Fault Currents

When a ground fault occurs, it can cause non-live parts to become live, leading to damage to equipment and harm to personnel. Therefore, the circuit breaker must reliably interrupt this fault current. The TN system standards define the disconnection time for this fault current.

The M-PACT plus breaker can reliably interrupt grounded faults within the defined time frame.

Relative Zero Voltage U0	Maximum breaking Time (AC system)
127V	0,8 sec.
230V	0,4 sec.
400V	0,2 sec.
> 400V	0,1 sec.

To protect standard circuits, M-PACT plus are equipped with a number of protection devices.

Overload Protection device

A highly accurate and widely adjustable overload protection device that has a setting range of 0,2 to 1 x the breaker rating. This device is normally set to a value that matches the design current (Ib).

Timed Short-circuit Protection Device

Providing a short circuit short time protection with a setting range of 2 to 12. The setting of this device depends on several parameters as the inrush characteristics of the protected devices. a protection against the weakest Short-circuit current and in some cases against fault currents to earth. To offer selectivity across multiple levels and allow the user to take inrush currents into account.

Ground Fault Protection

It is possible to combine two devices in one. both designed to detect Fault Currents to earth. They can be set as a multiple of the value of the Current Sensors mounted in the breaker and have a broad adjustment range of 0,2 to 1.

The first is a residual device that takes the sum of the current in the three phases and neutral. If this is no longer equal to zero and exceed the setting threshold it sends an alarm or trips the breaker.

The second allows the user to measure the return current running between the Earth leg and neutral. On detecting a fault to earth the device sends an alarm, or trips the breaker. multiple time bands allow the M-PACT plus to interrupt a fault within the timing required by the standards and offer selectivity across multiple levels.

Instantaneous Short-circuit Protection

Set as a multiple of the primary overload adjustment Ie this device offers a broad adjustment range of 2 to 15.

This device is normally used to limit the time that higher Short-circuit currents can run in the protected circuit. Whilst the timed Short-circuit protection device waits for a set time, the instantaneous device immediately trips the breaker once the set value is reached.

The device used in the M-PACT plus Breaker maintains selectivity by only reacting to the 2nd half wave of a Short-circuit current and uniquely allows the use of the 'Zone Selective Interlock' feature.

Application Guide

Protection of Generator sets, Motors, Capacitor banks and Transformers

Use of M-PACT plus in Automatic Power Transfer Systems (ATS)

The Electronic Trip Unit used in the M-PACT plus offers many additional protection devices, a full description of which can be found in trip unit section. Here a number of the possible applications of these devices is described briefly.

Protection of Generator sets

The overload and Short-circuit devices used to protect a generator need to react quicker and at lower current levels than those used to protect other devices.

After establishing the capabilities of the generator set under overload and Short-circuit conditions, the protection devices need to be adjusted accordingly.

On a Power Circuit breaker use of the 'faster' overload protection bands and a low setting of the timed Short-circuit protection ($2.5 \times I_r$) is recommended. The optional 3 phase Undervoltage protection available in the ME-P trip unit can also be considered.

Protection of Motors

On starting electrical Motors draw more current than when running under normal conditions. These starting currents differ strongly per type and should not cause tripping of the device protecting the circuit.

The IEC 60947-4 has defined four different 'operational' or 'Trip' classes:

Trip class	Required tripping times at		
	$1.2 \times I_n$	$1.5 \times I_n$	$7.2 \times I_n$
10A	t < 2 hours	t < 2 min.	$2 \leq t < 10$ sec.
10	t < 2 hours	t < 4 min.	$4 \leq t \leq 10$ sec.
20	t < 2 hours	t < 8 min.	$6 \leq t \leq 20$ sec.
30	t < 2 hours	t < 12 min.	$9 \leq t \leq 30$ sec.

This table is in some cases extended to include a 'trip class 40' (assumed to be a 15-40 second band at $7,2 \times I_n$).

On a Power Circuit breaker, use of the 'slower' protection bands that closely match the indicated classes is recommended (Tr setting from 8s to 24s curve).

Switching on a Motor also produces a high but very short inrush peak current which could activate the Short-circuit protection of a breaker and cause unexpected tripping. Here the timed Short-circuit device of a M-PACT plus must be set to at least $12 \times I_r$ with a time delay of 100 Milliseconds (Tsd sets to 0.1s). If an instantaneous protection device is present and switched on, a setting of at least $12 \times I_e$ is recommended.

After an overload event the Motor and wiring are still warm, immediate re-energization of the electrical circuit could result in damage of the electrical circuit and the motor.

The overload protection device must incorporate a thermal memory device that prevents re-energization before a certain cooling time has elapsed.

Note

For an overview of the used abbreviations see control unit section.

Furthermore, the prevention of anomalies as the motor losing a phase or a motor with blocked rotor need to be prevented and require additional protection devices.

Next to the 'standard' protection devices the ME Electronic Trip Unit has a thermal memory function, an optional 3phase Undervoltage relay and current unbalance device thus providing comprehensive motor protection.

Protection of Capacitor banks

M-PACT plus are designed to offer high making and breaking capacities under adverse conditions: The switching of capacitor banks has little to no effect on the breaker, its characteristics as a protective device or on its lifespan. However the current flowing in the circuit can trip a circuit breaker and a capacitor load does display certain anomalies. Here the current flowing in the circuit cannot be assumed to be the calculated capacitor current only. The effective current value is higher due to harmonic content (normally assumed as 30%) and an allowance must be made for tolerances in the capacitance of the units (10%). The protection devices of the Power Circuit Breaker must be set accordingly.

Protection of LV/LV Transformers

Transformers generally produce a very high inrush current. The crest values of the first half cycle may reach values of 15 to 25 time the normal rated current.

Manufactures data and tests have indicated that a protection device feeding a transformer must be capable of carrying the following current values without tripping.

Transformer value	imum crest inrush values		
	1st period	2nd period	After 3 periods
< 50 kVA	$25 \times I_n$	$12 \times I_n$	$5 \times I_n$
≥ 50 kVA	$15 \times I_n$	$8 \times I_n$	$3.5 \times I_n$

It is recommended that the timed Short-circuit protection of M-PACT plus is set to at least $8 \times I_r$ with a time delay of 100 Milliseconds (Tsd sets to 0.1). If an instantaneous protection device is present, the use of the extended adjustment range with setting of $15 \times I_e$ is advisable.

Automatic Transfer Systems

M-PACT plus are available with mechanical interlocks for 2 to 3 breakers and have a unique electrical network interlocking system allowing the user to completely lock out one of more breakers.

Application Guide

Environmental Considerations

Ambient temperature

M-PACT plus are designed to operate normally at temperatures of -5 degrees to +70°C. They can be used at temperatures down to -20°C with a reduced electrical and mechanical life span.

To prevent materials from reaching temperatures that have an adverse effect on their electrical and/or mechanical properties, de-rating factors must be applied when the device is used in ambient temperatures higher than 50°C.

Storage temperature

Circuit Breakers can be stored at non operational temperatures of -40 degrees up to +70°C.

Influence of Altitude

Up to an altitude of 2000m above sea level no de-rating of breaker current or rated voltage is applicable. For altitudes above 2000m the following de-rating factors apply:

Altitude Correction factors			
Altitude	≤ 2000M	2500M	4000M
Voltage (Ue)	1	0,95	0,8
Current (In)	1	0,99	0,96

Other atmospheric conditions

The M-PACT plus has been designed to operate at the temperatures and relative humidities defined in the EN 60947 clause 6.1.3.1. They also meet the requirements of the following standards:

Standard	Experiment
IEC 68-2-1	Cold temperature test
IEC 68-2-2	Dry heat test
IEC 68-2-3	Damp heat test
IEC 68-2-11	Corrosion resistance test
IEC 68-2-14	Change of temperature test
IEC 68-2-30	Damp heat cyclic test
IEC 721	Environmental resistance test

Shock and Vibration

Kover Circuit Breakers meet the shock and vibration requirements of the Germanischer Lloyd's Register of Shipping, the Germanischer Lloyd and the American Board of Shipping. They also meet the requirements of the following standards:

Standard	Experiment
IEC 68-2-6	Vibration test
IEC 68-2-27	Shock test
IEC 68-2-29	Bump test
IEC 68-2-31	Rough handling shock test

Other

All M-PACT plus meet the existing European ROHS directive and carry the CE mark.

Electromagnetic compatibility

The M-PACT plus and its electronic trip unit meet the most stringent requirements of the EN60947-2 and IEC 1004 standard. The following tests have been successfully completed.

Harmonics, current dips, interruptions and power frequency variations

All EN 60947 Annex F, Sub-clause F4.1 through 3 requirements covering non sinusoidal currents resulting from harmonics are met. Testing covering the following elements:

- Wave forms consisting of a fundamental + 3rd harmonic component at 50 and 60Hz
- Wave forms consisting of a fundamental + 5th harmonic component at 50 and 60Hz
- Composite wave forms with a fundamental component + 3rd, 5th and 7th harmonic at 50 and 60Hz
- Current dips and current interruptions
- Frequency variations from 45 to 65Hz in 1 Hz steps

Electrostatic discharge

EN 60947 Annex F, Sub-clause F and the IEC 1004-2

- Passed level 4, air discharge 15kV

Radiated, radio frequency, electromagnetic field immunity test

EN 60947-2 Annex F, Sub-clause F7 and the IEC 1000-4-3 (basic standard)

- Passed higher than level 4, Field strength 30V/m

Electrical fast transient/burst

EN 60947-2 Annex F, Sub-clause F5 and the IEC 1000-4-4 (basic standard)

- Passed level 4 burst peak voltage 4kV

Surge immunity test

EN 60947-2 Annex F, Sub-clause F5 and the IEC 1000-4-5 (basic standard)

- Passed level 4 Voltage 1,2µs/50µs 6kV; current 8µs/20µs 3kA

Dry heat test

EN 60947-2 Annex F, Sub-clause F8

- Passed all test requirements

Thermal shock test

EN 60947-2 Annex F, Sub-clause F9

- No nuisance tripping within the 28-day temperature cycles

Environmental Considerations

M-PACT plus Air circuit breaker

Dimensions

MEX1 Draw-out pattern

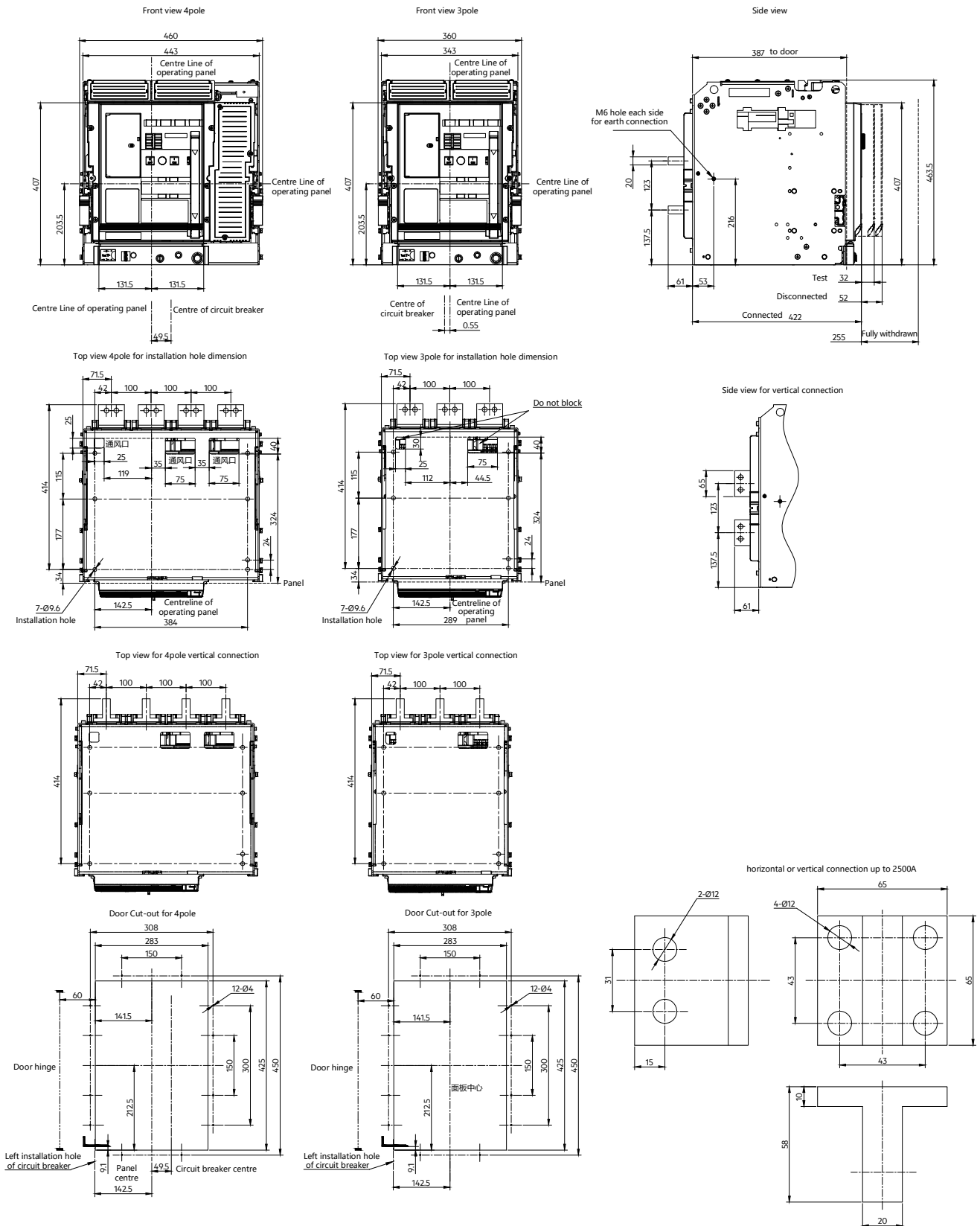

M-PACT plus Air circuit breaker
Dimensions

MEX2 Fixed Pattern

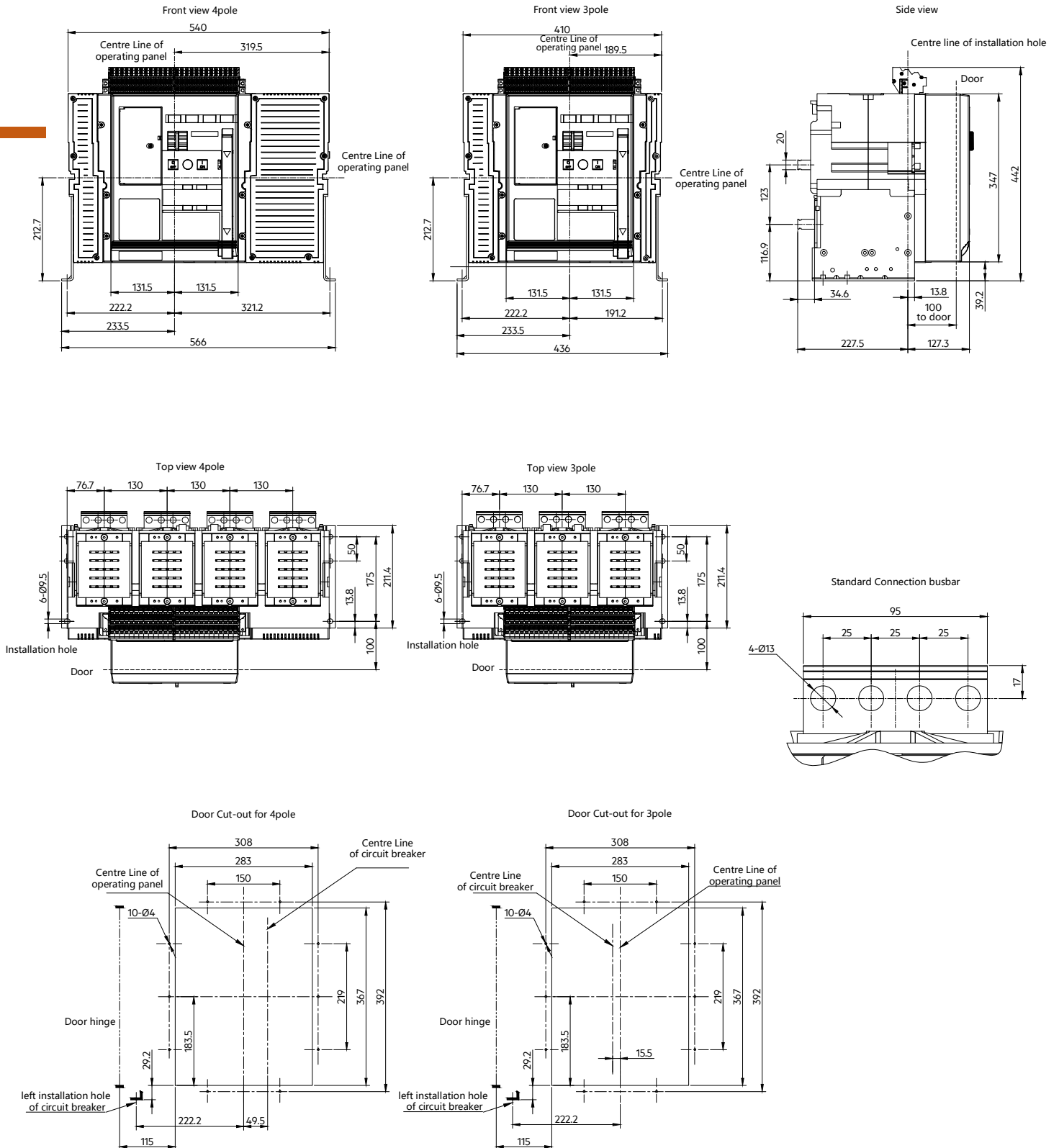

M-PACT plus Air circuit breaker

Dimensions

MEX2 Draw-out pattern

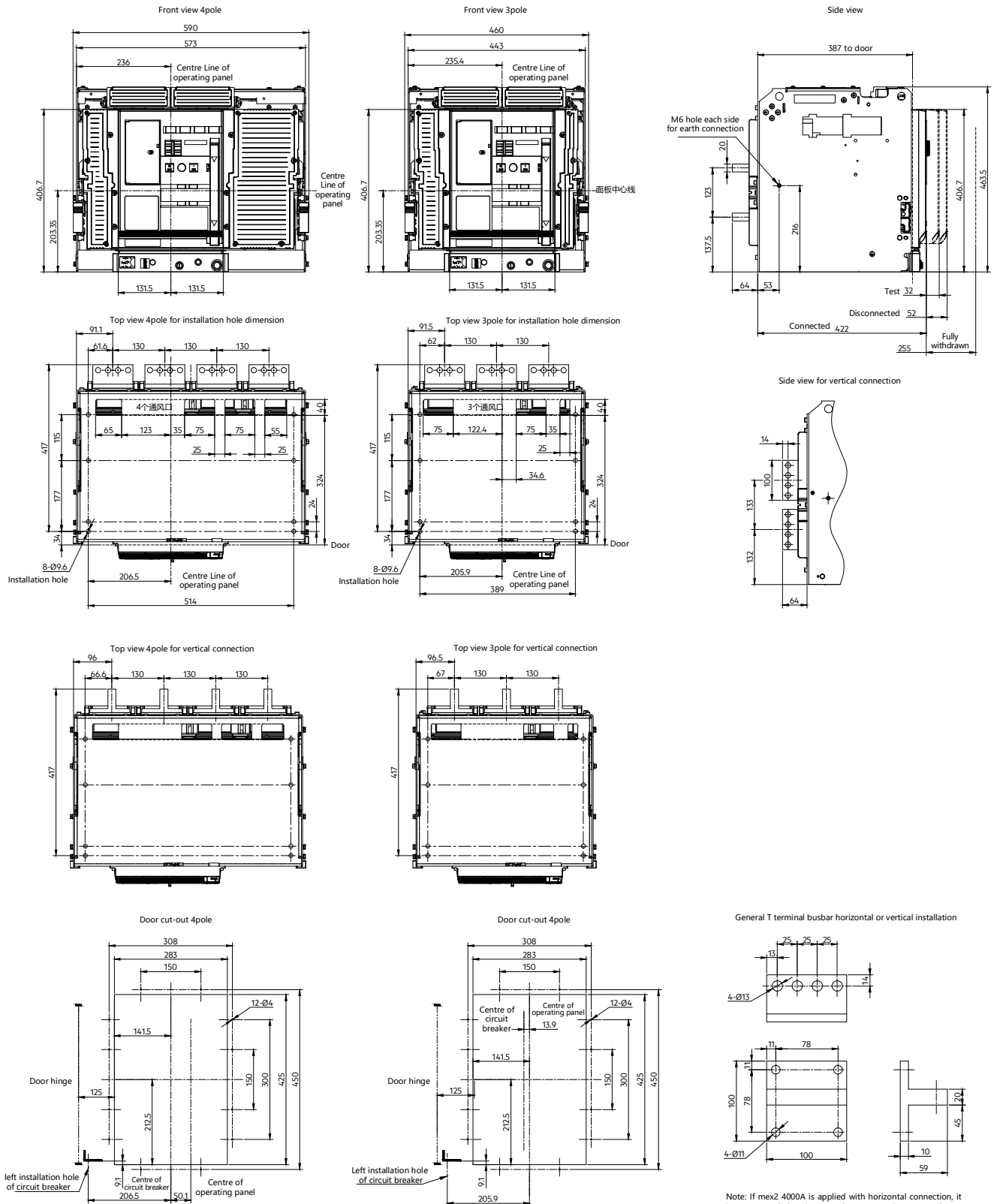

Dimensions

MEX1, MEX2, Fixed pattern optional connection busbar dimensions

MEX1 Fixed pattern rear vertical connection 2500A

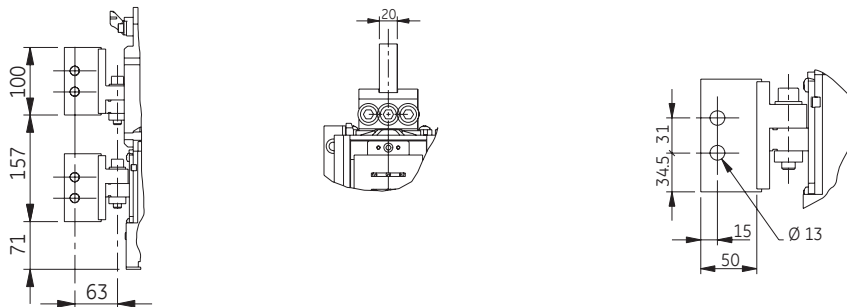

MEX2 Fixed pattern rear vertical connection

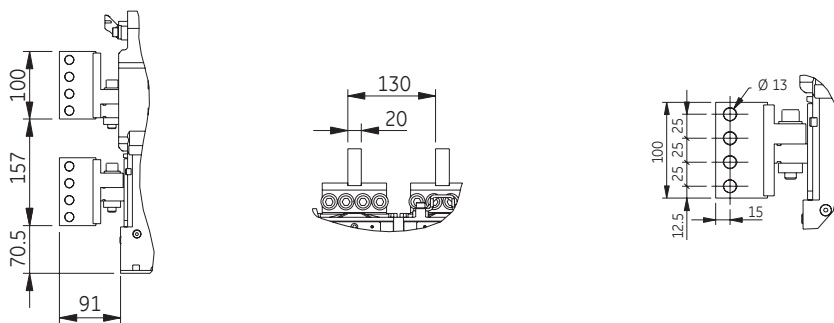

Note: If mex2 4000A is applied with horizontal connection, it is recommended to increase the cross section area, enhance the heat dissipation or reduce the rated capacity

M-PACT plus Air circuit breaker
Dimensions

MEX3 Fixed pattern

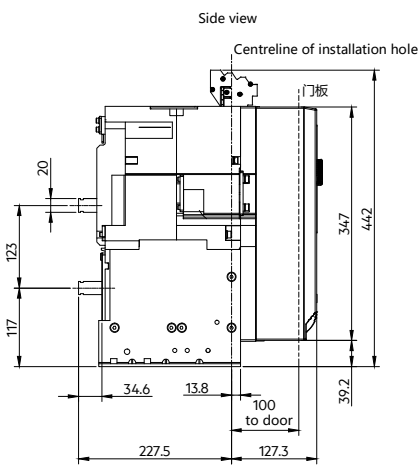
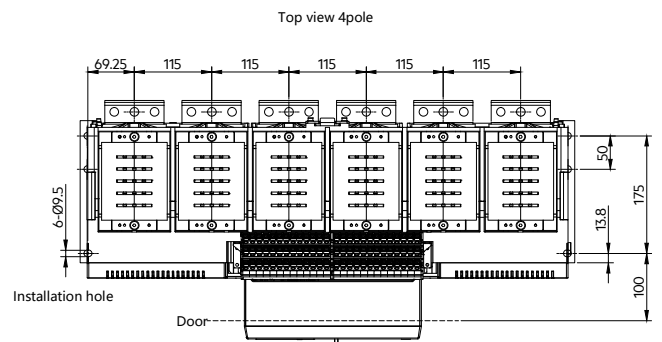
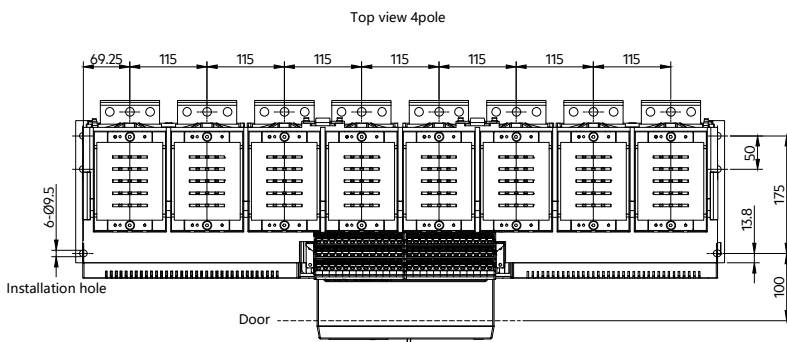
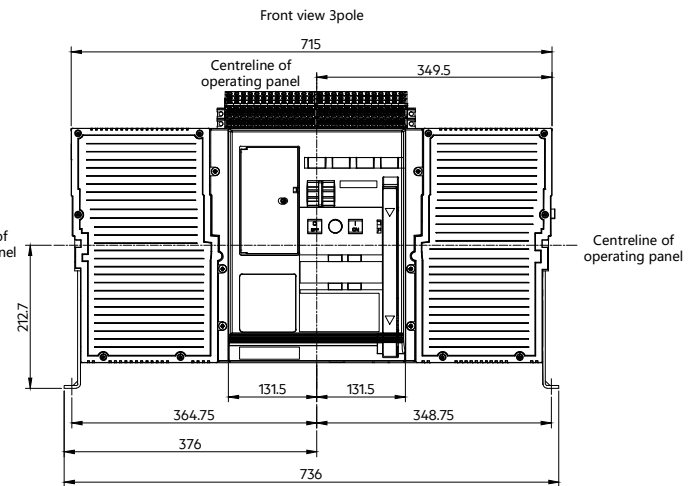
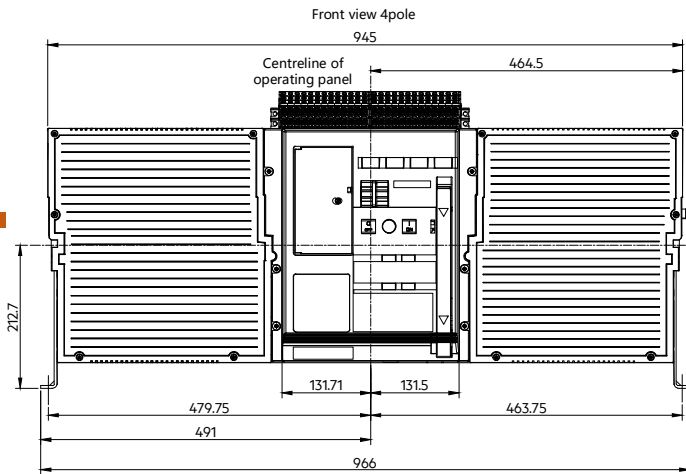

Standard rear vertical connection busbar up to 6400A

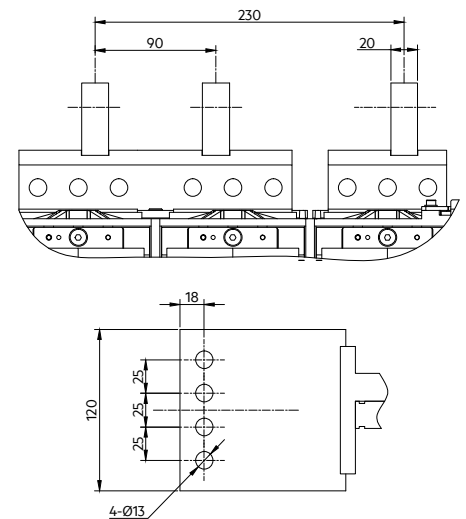
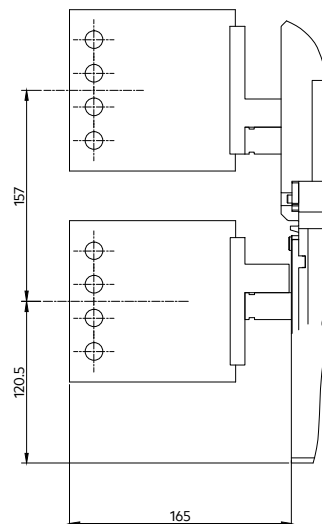

Standard rear vertical connection busbar up to 5000A

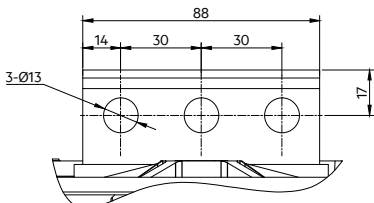

Note: If 6400A is applied with horizontal connection, it is recommended to increase the cross section area, enhance the heat dissipation or reduce the rated capacity

M-PACT plus Air circuit breaker

Dimensions

MEX3 Draw-out pattern

Front view 4pole

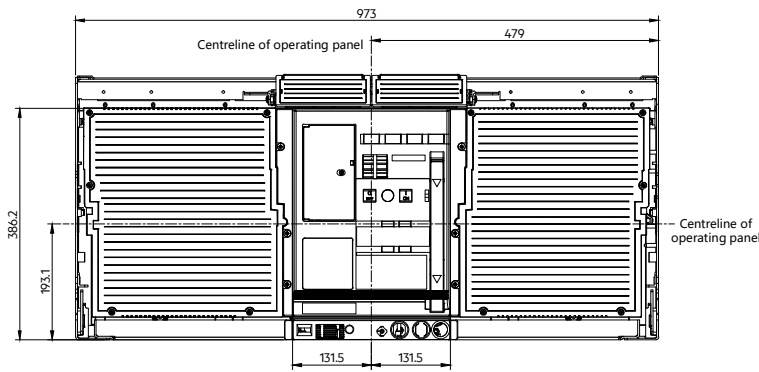

Front view 3pole

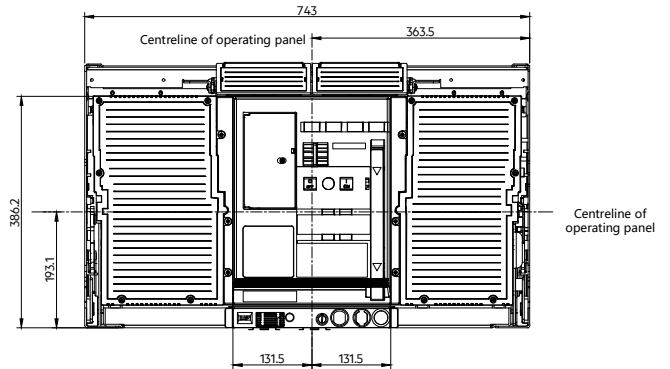

Top view 4pole bottom installation hole dimension

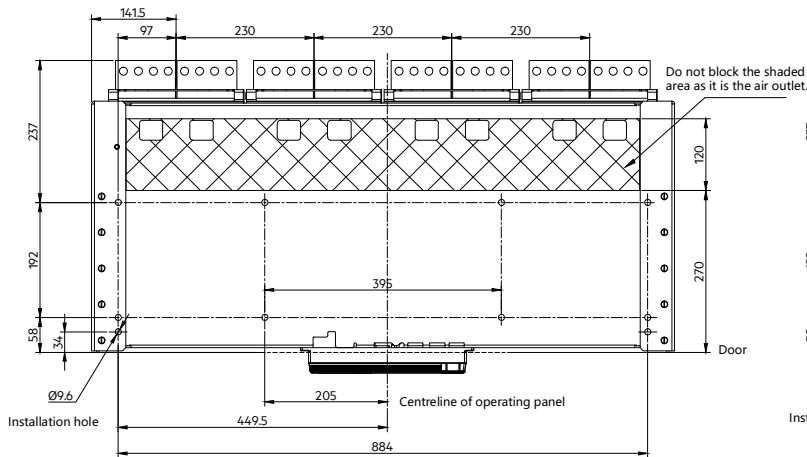

Top view 3pole bottom installation hole dimension

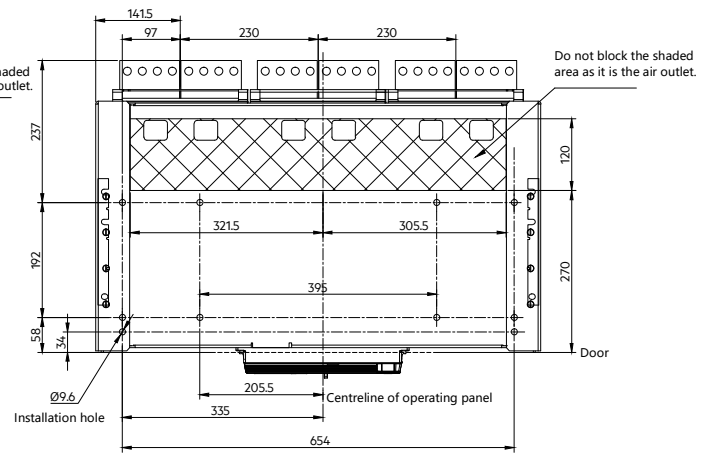

Side view

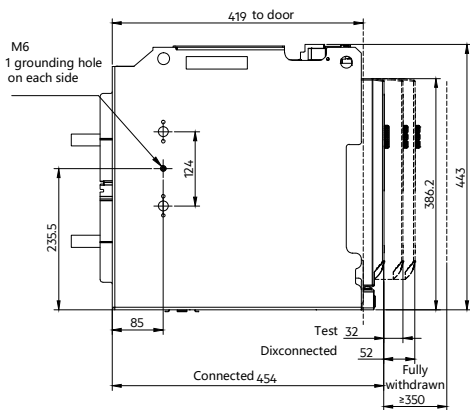

Standard rear horizontal connection busbar up to 5000A

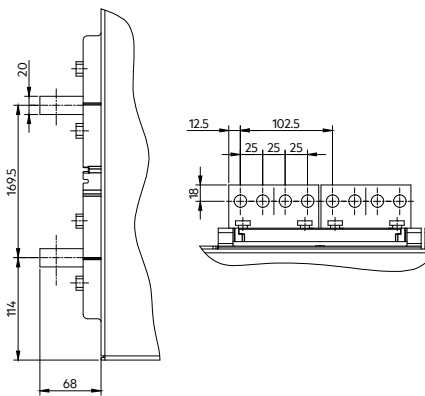

Standard rear vertical connection busbar up to 6400A

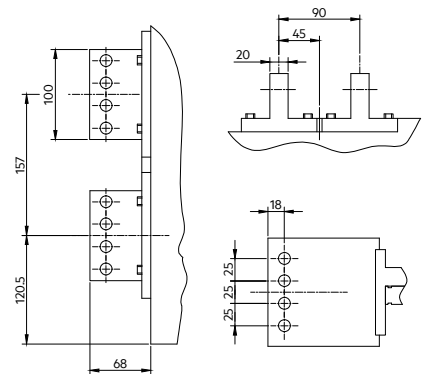

Note: If 6400A is applied with horizontal connection, it is recommended to increase the cross section area, enhance the heat dissipation or reduce the rated capacity

M-PACT plus Air circuit breaker
Dimensions

MEX3 Door cut-out dimension

MEX3 Fixed pattern door cut-out dimension

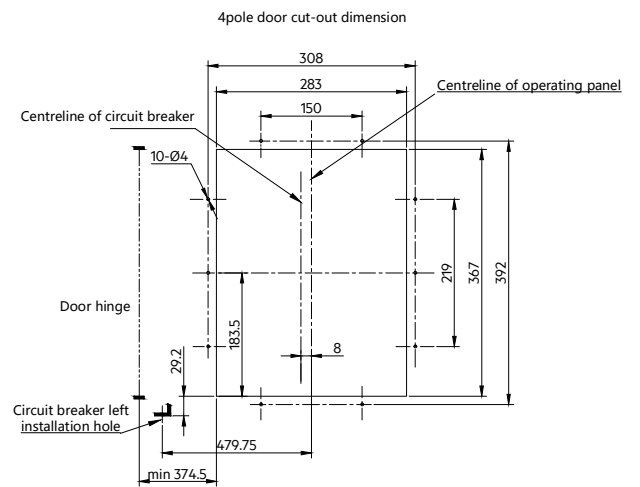
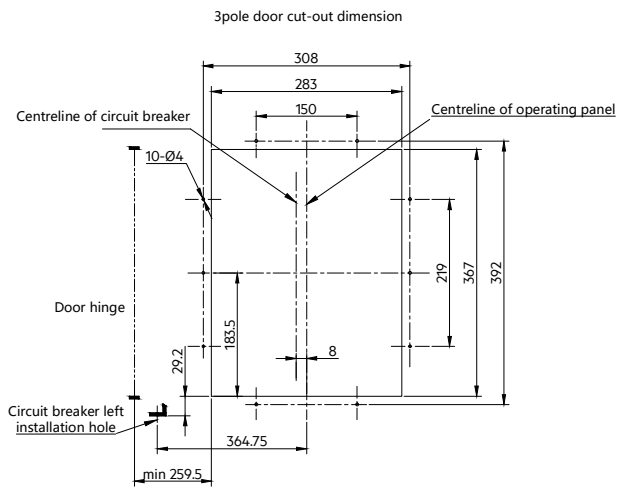

MEX3 draw-out pattern door cut-out dimension

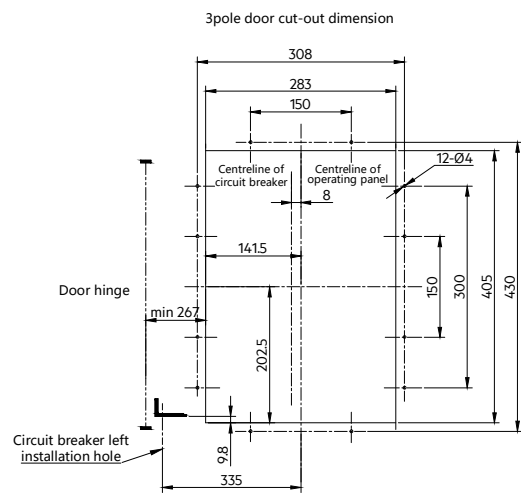
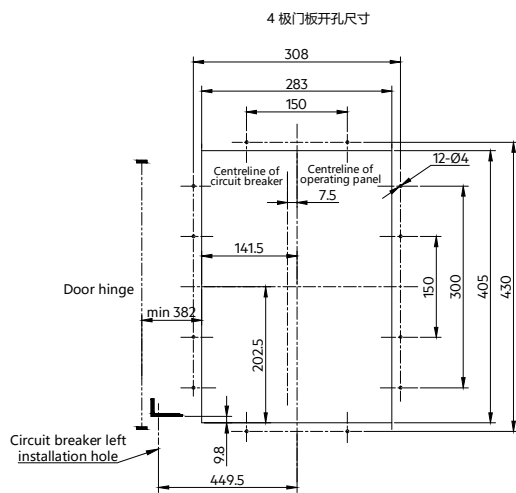

Dimensions

MEX Isolation phase separator dimension

MEX 1&2 standard isolation phase separator dimension for fixed pattern

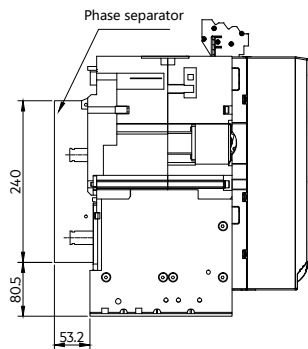

MEX2 extended isolation phase separator dimension for fixed pattern

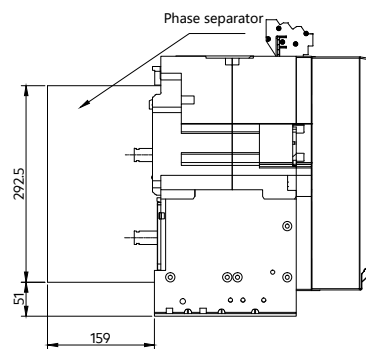

MEX 3 standard isolation phase separator dimension for fixed pattern

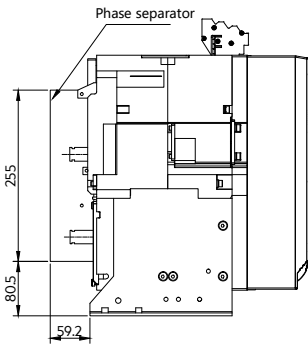

MEX3 extended isolation phase separator dimension for fixed pattern

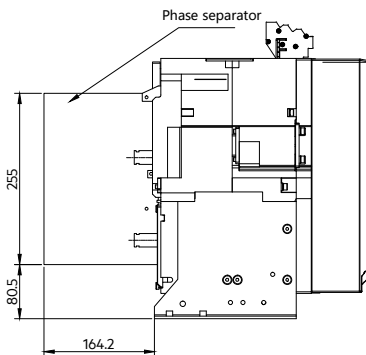

MEX extended isolation phase separator dimension for draw-out pattern

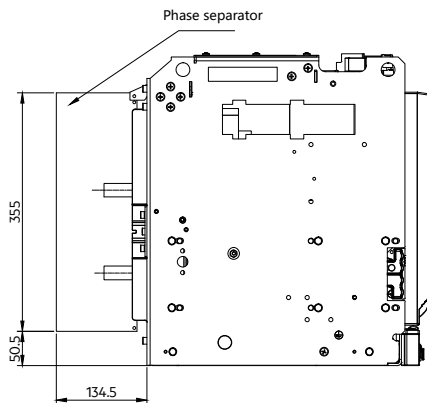

Dimensions

UVR Time delay module & external power module

UVR Time delay module

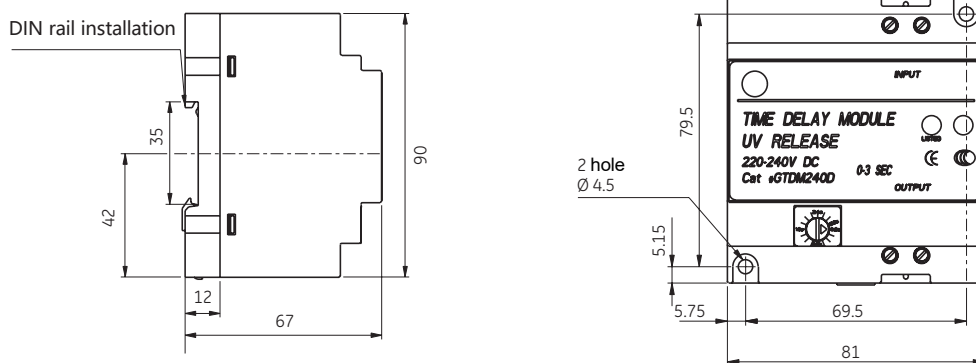

24V External power module

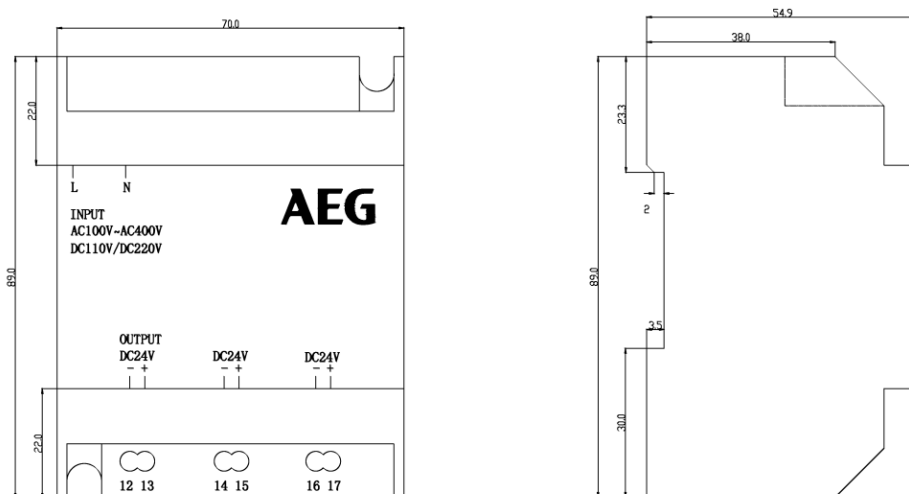

M-PACT plus Air circuit breaker

Dimensions

Voltage measurement module for 400/690/800V system

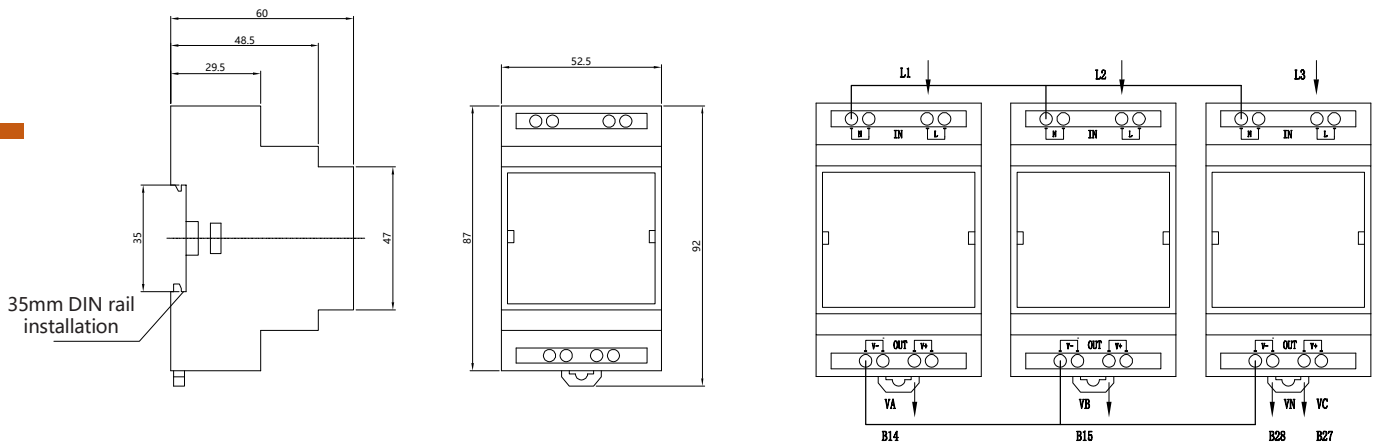

Voltage measurement module for 1140V system

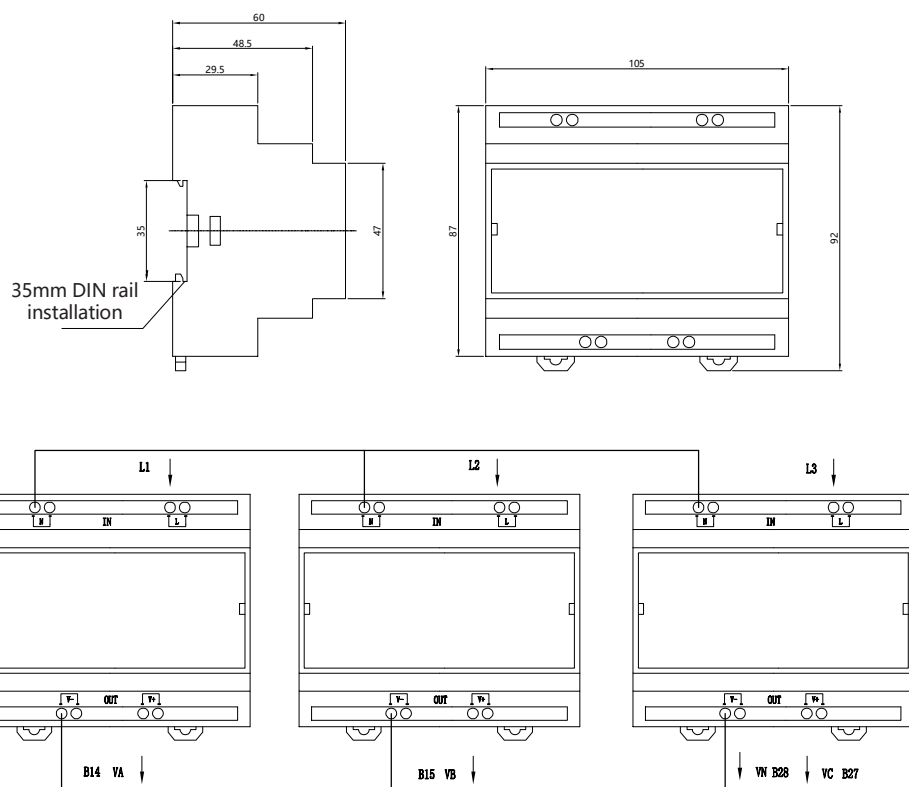

M-PACT plus Air circuit breaker Dimensions

Rogowski coil, current transformer, door interlock mechanism, wall-mounted installation accessories

External rogowski coil

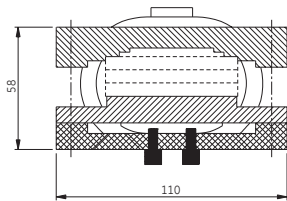
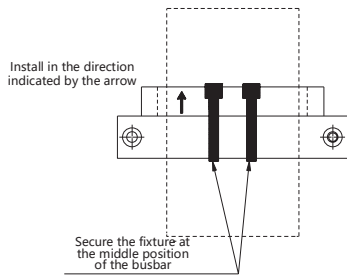

Note: Install 2 coils for currents greater than 4000A

External current transformer

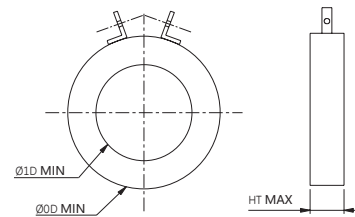

Rated current	1D	0D	HT
400A	94	144	24
630A	85	135	30
2000A	87	151	31
3200A	84	154	34
4000A	81	154	57
5000A	85	198	58
6400A	85	210	65

Door interlock mechanism

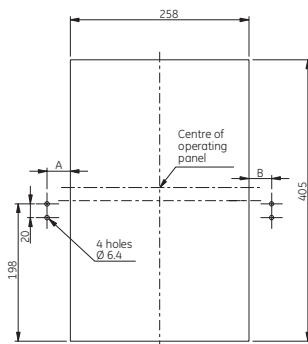

Frame	A
F1-3P	30
F1-4P	100

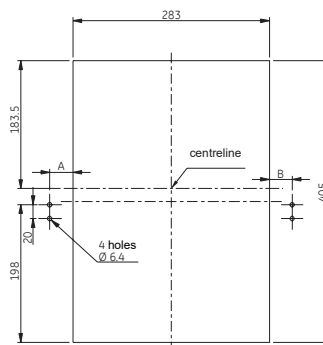

Frame	A	B
F1-3P	33.5	32.5
F1-4p	33.5	132.5
F2-3P	98.5	67.5
F2-4P	98.5	197.5
F3-3P	240.5	225.5
F3-4P	355.5	340.5

Wall-mounted installation (fixed pattern and draw-out pattern, front connection for primary connection)

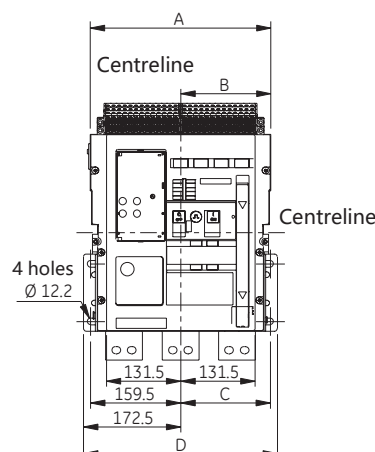
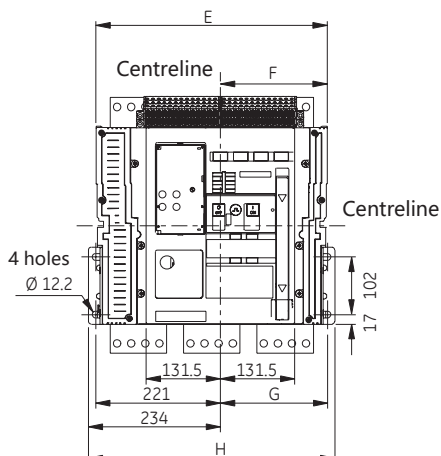

	3pole	4pole
A	320	420
B	159.5	259.5
C	158.5	258.5
D	344	444
E	410	540
F	189.5	319.5
G	190	320
H	437	567

Dimensions

2-Way Mechanical Interlocking Mechanism

2-way mechanical interlocking mechanism / Fixed pattern - Front connection / Rear connection

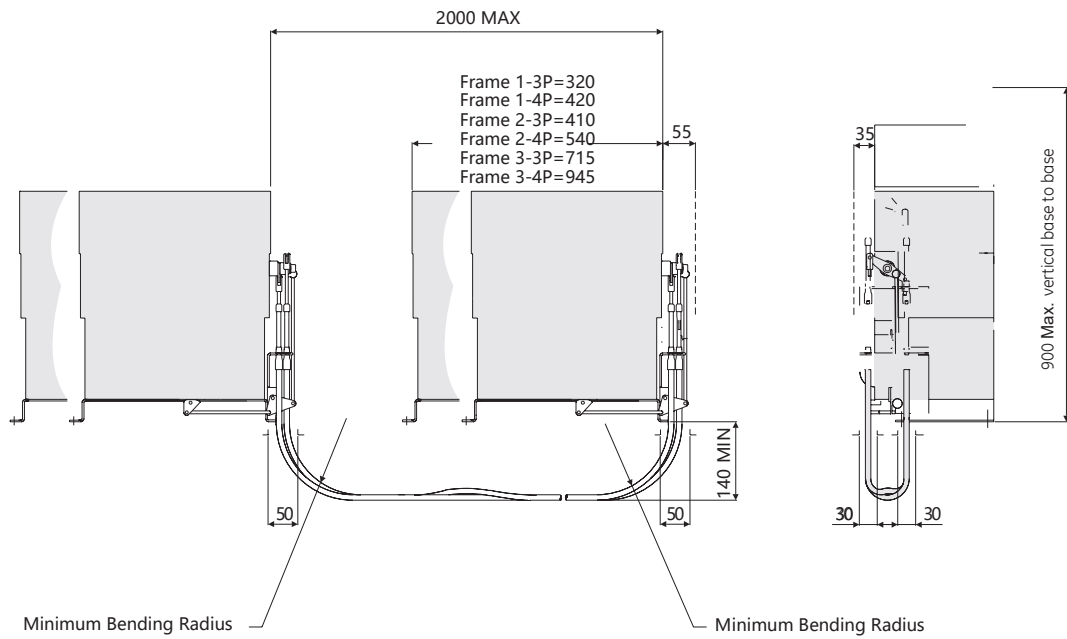

2-way mechanical interlocking mechanism / Draw-out pattern - Front connection / Rear connection

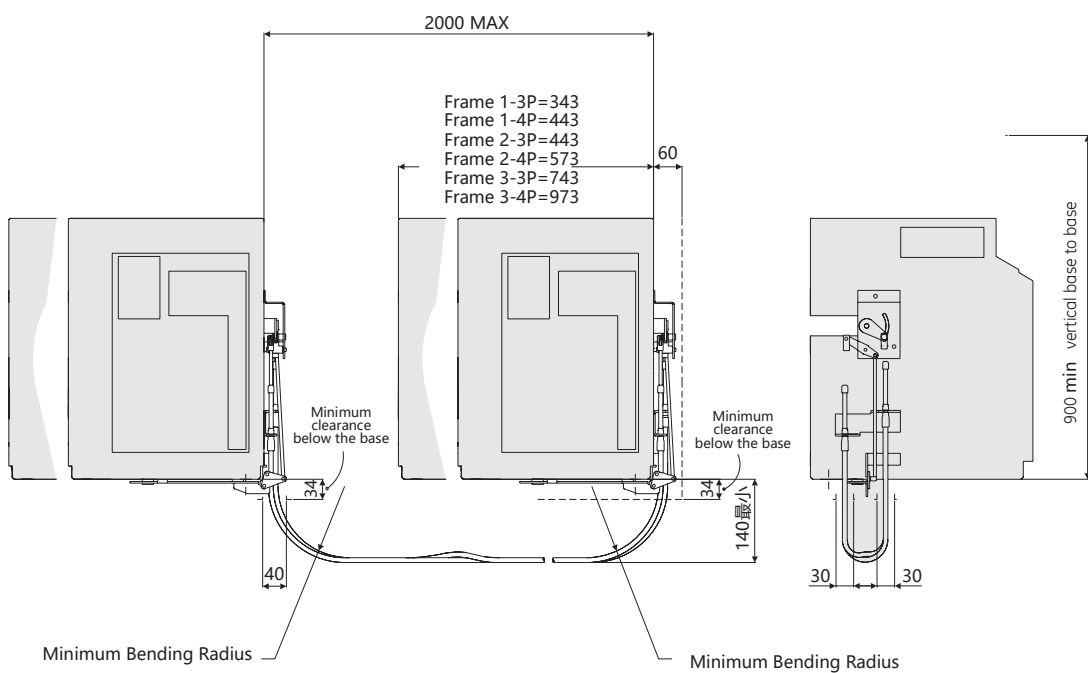

Dimensions

3-way Mechanical Interlocking Mechanism

3-way mechanical interlocking mechanism / Fixed pattern - Front connection / Rear connection

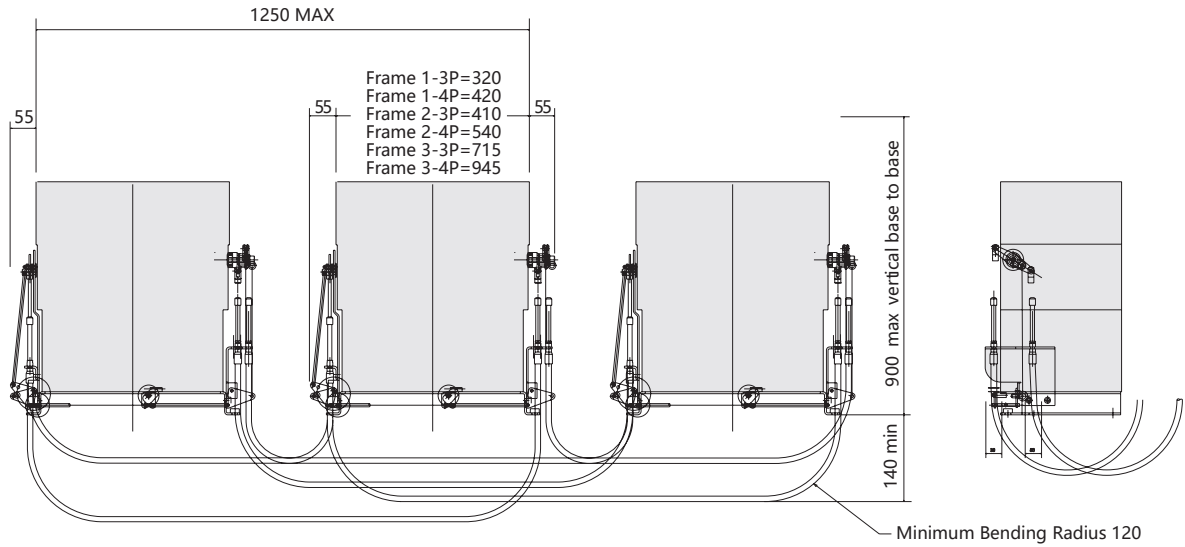

3-way mechanical interlocking mechanism / draw-out pattern - Front connection / Rear connection

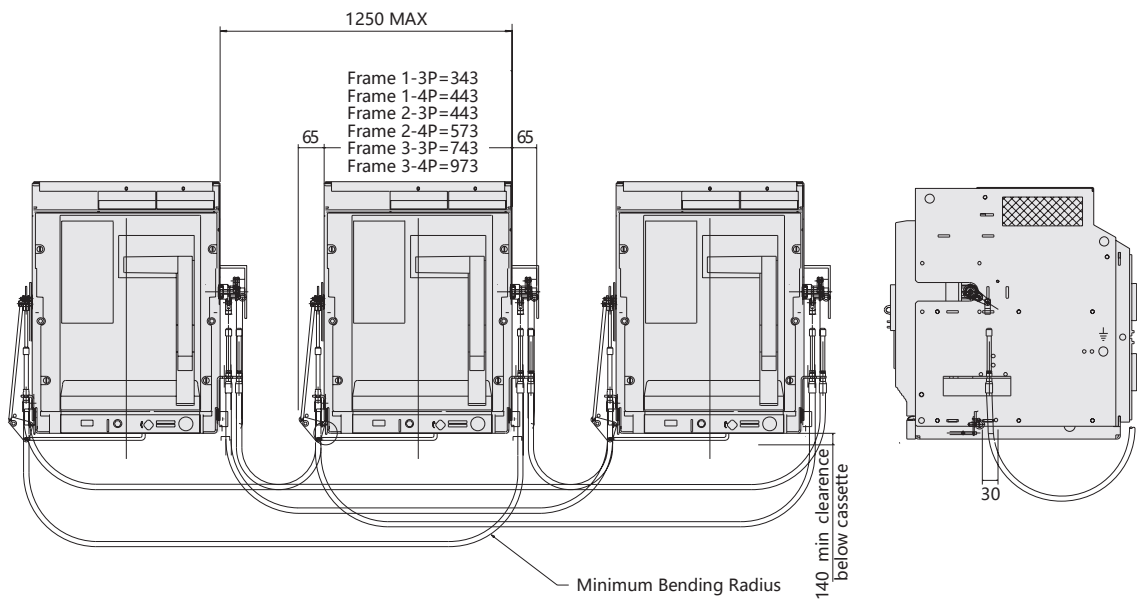

M-PACT plus Air circuit breaker

Wiring Diagrams

ME Control Unit Wiring Diagram

Terminal A standard wiring diagram

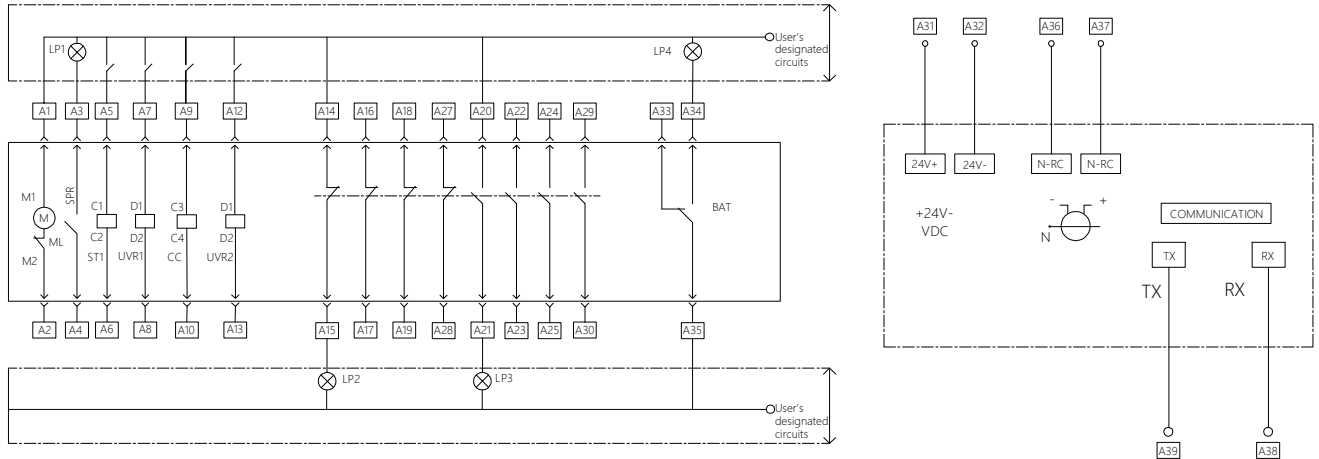

Terminal A wiring diagram for optional function

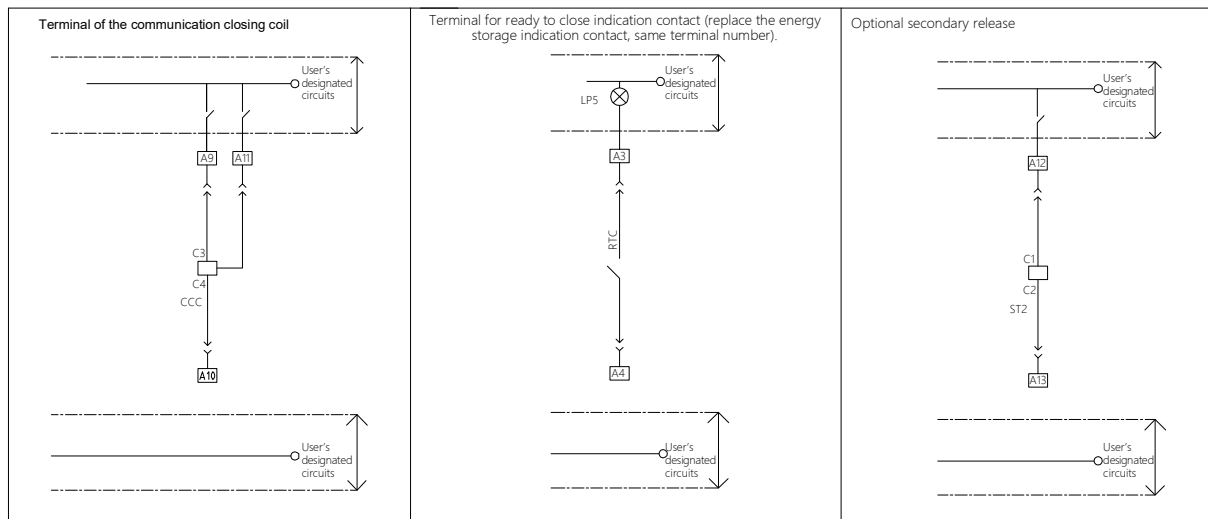

Acronyms explanation:

CC: Closing coil
 ST: Shunt release
 UVR: Undervoltage release
 SPR: Spring status
 RTC: Ready to close
 M: Motor operator
 BAT: Bell alarm trip

CCC: Command Closing Coil
 24V+/24V-: Auxiliary power supply to control unit
 N-RC: External rogowski coil for neutral line
 RXD: Communication terminal
 TXD: Communication terminal
 A14-A19, A27-A28: Normally Closed Contact of the Changeover Switch
 A25, A29-A30: Normally Opened Contact of the Changeover Switch

M-PACT plus Air circuit breaker
Wiring Diagrams

ME Control Unit Wiring Diagram

Terminal B standard wiring diagram (A03 A06 control unit not applicable)

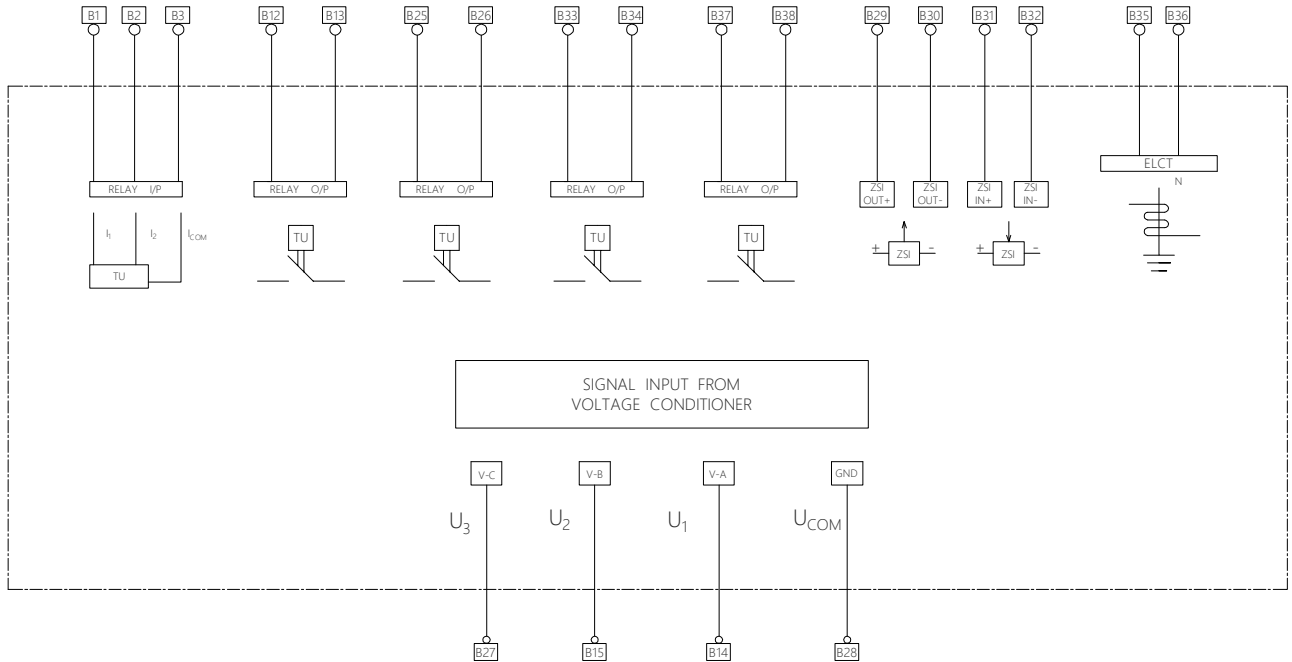
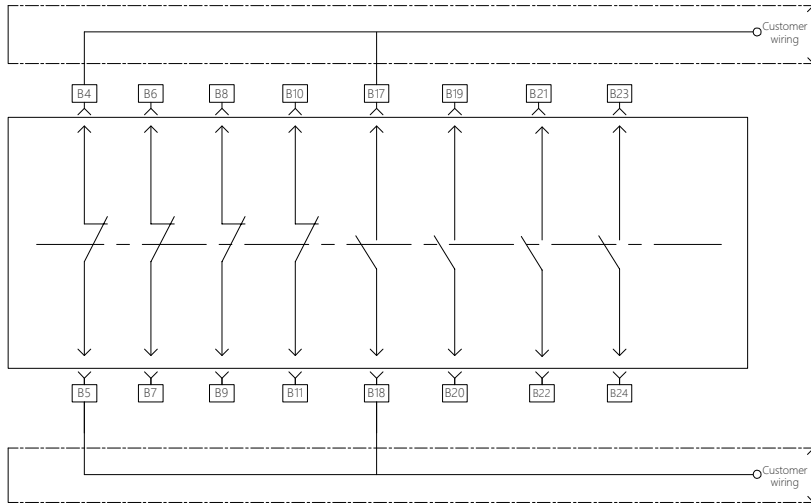

Acronyms explanation:

ELCT: Earth leg CT input
 RELAY O/P: Relay output
 RELAY I/P: Relay input
 V-A/V-B/V-C: Signal input from voltage conditioner
 GND: Ground for voltage

ZSI OUT: Zone selective interlock output
 ZSI INPUT: Zone selective input
 B4-B11: Normally Closed Contact of the Changeover Switch
 B17-B24: Normally opened Contact of the Changeover Switch

Wiring Diagrams

Optional indicator for base position

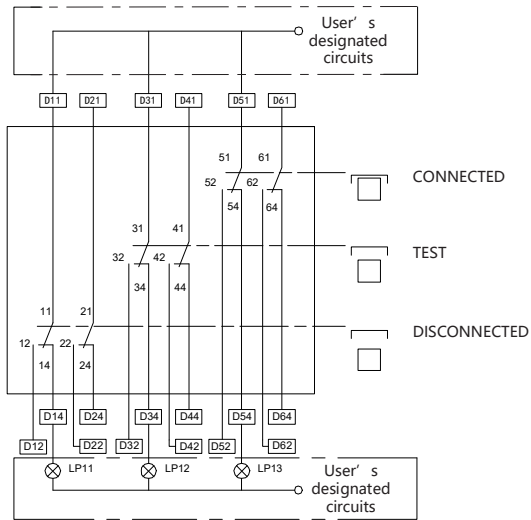

User External Connection Indication

LP11: Circuit breaker at disconnected position

LP12: Circuit breaker at test position

LP13: Circuit breaker at connected position

M-PACT plus Air circuit breaker

Order Codes

1.Order number:	2.Requiring date:	3.Bidding factory:	4.Ordering quantity:															
5.Project:	6.Purchaser:	7.Industry:																
Technical specification																		
Product type MEX	<input type="checkbox"/>	<input type="checkbox"/>	<input type="checkbox"/>	<input type="checkbox"/>	<input type="checkbox"/>	<input type="checkbox"/>	<input type="checkbox"/>	<input type="checkbox"/>	<input type="checkbox"/>	<input type="checkbox"/>	<input type="checkbox"/>	<input type="checkbox"/>	<input type="checkbox"/>	<input type="checkbox"/>	<input type="checkbox"/>	Product type	<input type="checkbox"/> Draw-out	<input type="checkbox"/> Fixed
Rated working voltage	<input type="checkbox"/> AC415V	<input type="checkbox"/> AC690V	<input type="checkbox"/> AC800V	<input type="checkbox"/> AC1140V														
Frame 1, 400-2500A	<input type="checkbox"/> N, 55/45kA, AC415/690V	<input type="checkbox"/> S,70/55kA, AC415/690V	<input type="checkbox"/> H,85/66kA, AC415/690V															
Frame 2, 400-4000A	<input type="checkbox"/> N,55/55kA, AC415/690V	<input type="checkbox"/> S,70/66kA, AC415/690V	<input type="checkbox"/> H, 85/85kA, AC415/690V															
	<input type="checkbox"/> M,100/85kA, AC415/690V																	
	<input type="checkbox"/> C, 66kA, AC800V	<input type="checkbox"/> F, 66kA, AC1140V																
Frame 3, 3200-6400A	<input type="checkbox"/> M,100kA, AC415/690V	<input type="checkbox"/> L,150/65kA, AC690/1140V	<input type="checkbox"/> H, 80kA, AC1140V															
Rating current	<input type="checkbox"/> 400A	<input type="checkbox"/> 630A	<input type="checkbox"/> 800A	<input type="checkbox"/> 1000A	<input type="checkbox"/> 1250A	<input type="checkbox"/> 1600A												
	<input type="checkbox"/> 2000A	<input type="checkbox"/> 2500A	<input type="checkbox"/> 3200A	<input type="checkbox"/> 4000A	<input type="checkbox"/> 5000A	<input type="checkbox"/> 6400A												
Poles	<input type="checkbox"/> 3pole	<input type="checkbox"/> 4pole neutral pole on right(standard)	<input type="checkbox"/> 4 pole neutral pole on left															
Preferred connection for draw-out type	<input type="checkbox"/> T terminal busbar, rear horizontal (1)	<input type="checkbox"/> T terminal busbar, rear vertical																
Preferred connection for fixed type	<input type="checkbox"/> Standard rear connection	<input type="checkbox"/> Upper terminal vertical adaptor	<input type="checkbox"/> Bottom terminal vertical adaptor															
Control unit	<input type="checkbox"/> A03	<input type="checkbox"/> A06	<input type="checkbox"/> A13	<input type="checkbox"/> A16														
	<input type="checkbox"/> P13H	<input type="checkbox"/> P16H	<input type="checkbox"/> X13H	<input type="checkbox"/> X16H	<input type="checkbox"/> Non-protection													
Ground fault protection type	<input type="checkbox"/> GF SUM	<input type="checkbox"/> GF CT																
Extended Features	<input type="checkbox"/> Modbus communication Module	<input type="checkbox"/> DI/DO module																
Auxiliary power supply to control unit	<input type="checkbox"/> Wide Voltage Module, AC 100-400V , DC 110/220V																	
Control voltage																		
Motor operator	<input type="checkbox"/> DC24V	<input type="checkbox"/> AC/DC110-130V	<input type="checkbox"/> AC/DC220-240V	<input type="checkbox"/> AC250-277V	<input type="checkbox"/> AC380-415V													
Close coil	<input type="checkbox"/> DC24V	<input type="checkbox"/> AC/DC110-130V	<input type="checkbox"/> AC/DC220-240V	<input type="checkbox"/> AC250-277V	<input type="checkbox"/> AC380-415V													
Shunt release coil	<input type="checkbox"/> DC24V	<input type="checkbox"/> AC/DC110-130V	<input type="checkbox"/> AC/DC220-240V	<input type="checkbox"/> AC250-277V	<input type="checkbox"/> AC380-415V													
Undervoltage coil	<input type="checkbox"/> DC24V	<input type="checkbox"/> AC/DC110-130V	<input type="checkbox"/> AC/DC220-240V	<input type="checkbox"/> AC250-277V	<input type="checkbox"/> AC380-415V													
Time delay undervoltage coil	<input type="checkbox"/> DC24V	<input type="checkbox"/> AC/DC110-130V	<input type="checkbox"/> AC/DC220-240V	<input type="checkbox"/> AC250-277V	<input type="checkbox"/> AC380-415V													
Auxiliary contact	<input type="checkbox"/> Power type 4NO+4NC	<input type="checkbox"/> Power type 8NO+8NC ²⁾	<input type="checkbox"/> Power type 4NO+4NC, Signal type 4NO+4NC ²⁾															
Bell alarm trip	<input type="checkbox"/> Power type1NO+1NC	<input type="checkbox"/> Signal type 1NO+1NC																
	<input type="checkbox"/> Operations Counter	<input type="checkbox"/> Ready to close contact 1NO																
Draw-out cassette Three-Position Contact	<input type="checkbox"/> Ready to close contact 1NO+1NC	<input type="checkbox"/> Power type 2NO+2NC																
	<input type="checkbox"/> Power type1NO+1NC, Signal type1NO+1NC																	
OFF position padlock	<input type="checkbox"/> Lock A	<input type="checkbox"/> Lock B	<input type="checkbox"/> Lock C	<input type="checkbox"/> Lock D	<input type="checkbox"/> Lock E													
Mechanical cable interlock	<input type="checkbox"/> Interlock A	<input type="checkbox"/> Interlock B	<input type="checkbox"/> Interlock C	<input type="checkbox"/> Interlock D														
Cable length	<input type="checkbox"/> 1.5m	<input type="checkbox"/> 2m	<input type="checkbox"/> 3m															
	<input type="checkbox"/> Breaker Key lock facilities	<input type="checkbox"/> Phase separators																
Please note any other special requirements here.																		

Confirm and stamp by customer :

Standard configuration of the circuit breaker: motor operator (with signal output), closing coil, shunt release coil, 4NO+4NC power type Auxiliary contacts, external auxiliary power supply to control unit, standard door frame, draw-out cassette for the draw-out circuit breaker, rear T-type or L-type terminals (draw-out type).

Note1: If Frame2 4000A or Frame3 6400A is applied with horizontal connection, it is recommended to increase the bar cross section area, enhance the heat dissipation or reduce the rated capacity.

Note 2: The A03 and A06 control units do not support the extended power type with 8NO+8NC; the power type with 4NO+4NC, and the signal type with 4NO+4NC auxiliary contacts.

GEIS

GEIS Electric

Website: www.geis.tech

Hotline: +86 400-820-5234

This catalog may be subjected to revision without prior notice.

Version No.: GENCLVAM26V2

