

GEIS

GEIS-X

Busway System

GEIS Electrical Protection

Safer Smarter Greener

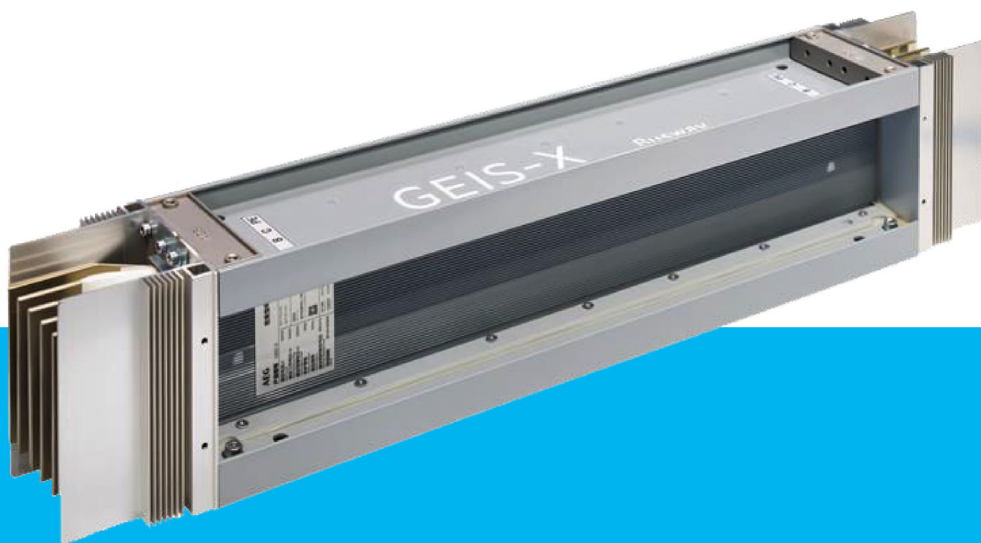

About GEIS

GEIS was established in 2019 following the spin-off of several businesses and assets that ABB had acquired from GE on July 1, 2018, including 3 manufacturing centers, Warehousing & Trading business at FTZ, China Technology Center.

- Components: Full range of circuit breakers up to 40.5kV: Medium voltage vacuum circuit breakers, LV circuit breakers: ACB, MCCB, MCB, RCD, RCBO: Control components.
- Equipment: MV switchgear (Air insulation and Gas Insulation Technology), LV switchgear, switchboard.
- Medium voltage distribution transformer.
- Medium voltage ATS system (Paralleling Switchgear).

After the separation, all the above product lines were rebranded as AEG for selected markets and GEIS for global markets. Moreover, GEIS has expanded its technological portfolio to include medium-voltage controls such as VFDs and soft starters, as well as ATS systems and EV chargers.



Quality is Built-in

Where Technology Meets Manufacturing Excellence for Customers

- Since 2000, we have been specializing in localizing world-class products and manufacturing technologies, developing strong expertise and a highly capable team.
- Vertical integrated Shanghai Manufacturing Center brought key manufacturing processes into a 75,000 m² facility, enabling high-quality, high-efficiency production and fostering innovation. A dedicated R&D team committed to developing products that meet global standards and serve diverse applications.
- Global expansion: GEIS's first Thailand facility makes it easier to serve customers worldwide.



GEIS deliver complete range of products for the evolving electrification needs:



SecoVac VCB



M-PACT Plus ACB



Elfa Series MCB/RCBO



SolidDrive MV VFD



SecoGear MV Switchgear



RMU Gas Insulated Switchgear



WaveCast Transformer



MLS LV Switchgear

GEIS-X Busway system

Fully upgraded Busway system

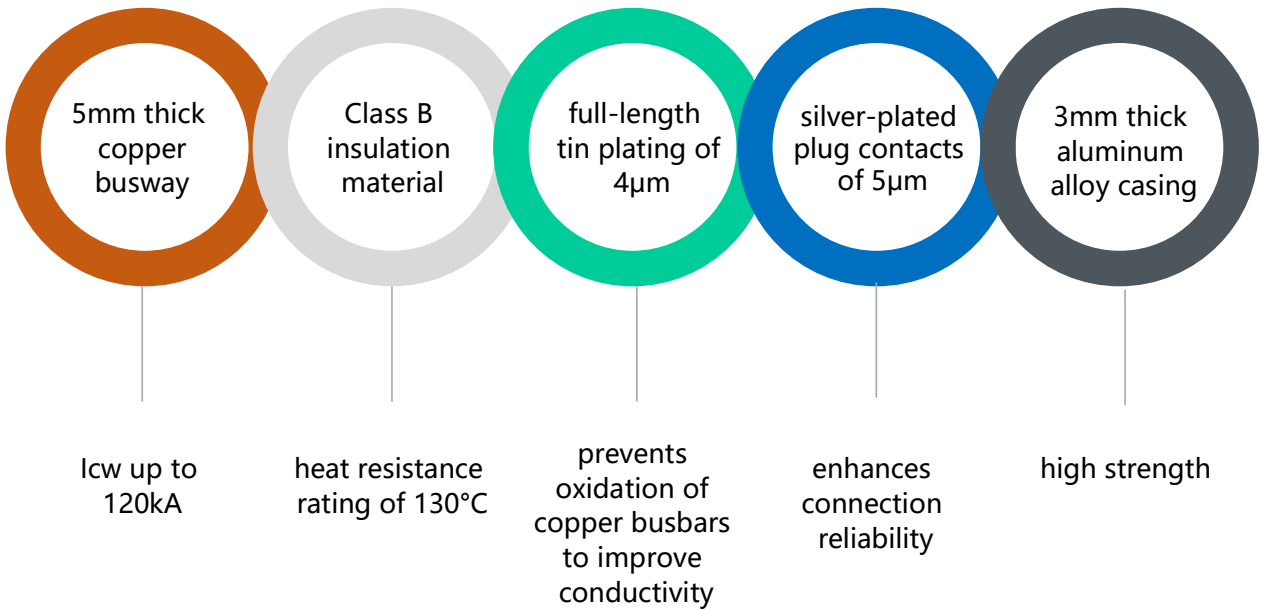
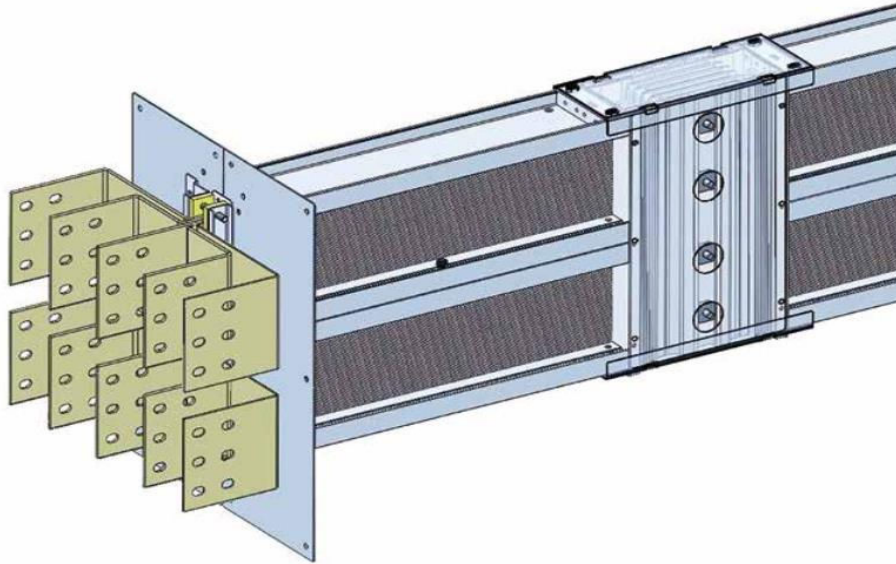

High-performance compact bus duct

The GEIS-X compact Busway features a high-standard design approach, from the selection of conductive and insulating materials to the protection of the product and the convenience for customers. By enhancing conductivity, it saves energy during electricity transmission and usage.

The high reliability of its electrical performance and mechanical strength ensures that the product is maintenance-free throughout its lifespan, delivering efficient and stable performance to help customers achieve added-value electrical services.

Catalogue

A

Product

B

Selection Guide

C

Technical data

D

Functional units

E

Plug-in-Boxes

F

Installation

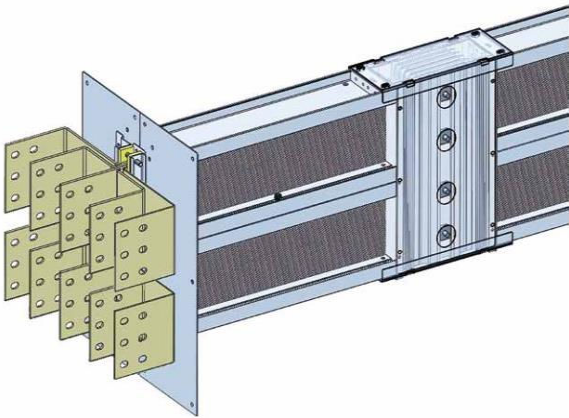

Products

The GEIS-X busway is designed with the goal of " peak carbon and carbon neutrality" to reduce the energy consumption of electrical transmission, making it a responsible product for future societies. Conductive materials utilize high-performance, high-quality pure copper as the transmission solution. The product line is complete, standardized , compact in size, and large in capacity. The GEIS-X busway products are suitable for AC 50Hz, rated voltages of 400V/690V/1000V, and rated currents up to 6300A in three-phase four-wire and three-phase five-wire power distribution system projects.

The design process of the GEIS-X busway utilized advanced platforms and methods, selecting 5mm thick high-quality pure copper and Class B 130°C insulation film materials, with careful consideration of electrical performance parameters. Located at the GEIS busway manufacturing center, the manufacturing process is centered around the ALPS Lean Manufacturing System, featuring digital lean management to provide reliable products.

The exterior of the GEIS-X busway adopts a highly popular industrial color scheme, greatly considering the practicality of the product on site while balancing performance and appearance.

The GEIS-X busway have a large current capacity and excellent electrical and mechanical performance. It utilizes high-strength alloys for its casing, resulting in significantly reduced footprint compared to traditional distribution methods, strong short-circuit load capability, long service life, flexibility in equipment addition or modification, high reliability, compact size, lightweight, simple connection, easy construction, and inspection.

It is the preferred power transmission solution for modern construction and distribution.

The GEIS-X busway complies with international and Chinese standards including IEC 61439-1, IEC 61439-6, GB/T 7251.1, and GB/T 7251.6. It has obtained China Compulsory Certification (CCC).

The GEIS-X busway meet the testing requirements of CB and CE.

The GEIS-X busway system continuously serves customers and markets with perfect and highly competitive products in terms of design, material selection, craftsmanship, manufacturing, etc. The products are widely used in key industries such as large industrial plants, petrochemicals, energy and power, municipal construction, data centers , rail transportation, airports, hospitals, commercial complexes, hotels, buildings, etc., providing value-added services to customers and society.



Execution Standard:
IEC 61439-6
GB/T 7251.6-2015





Copper conductor materials

The GEIS-X busway, as a low impedance electric power transmission system, adopts high-quality pure copper conductors with a copper content of over 99.95%. Through scientific and precise simulation analysis calculations, the selected copper busway cross-sectional area and current-carrying capacity far exceed industry standards. The main busbars and N phase of the entire series adopt 5mm thick pure copper conductors, ensuring excellent conductivity while comprehensively improving the short-term withstand capability of the intensive busway, with a maximum I_{cw} of up to 120kA.



Aluminum alloy casing

The GEIS-X busway series uses high-strength, new aluminum alloy materials, shaped through specialized molds and manufacturing processes in one go. The surface coating employs fully automated electrostatic epoxy resin powder spraying, applied by automatic unmanned spray guns. Pre-treatment involves spray-type back-flushing, ensuring an even coating with no dead angles. Drying and curing are performed using natural gas heating, which is environmentally friendly. The intensive busway integrates high strength, high protection, and lightweight characteristics, making it easy to install and durable.



Insulation protection

The busway utilizes Class B insulation film materials, which can withstand temperatures up to 130°C. Combined with a multi-layer folding and wrapping process, the excellent insulation properties easily elevate the product's insulation voltage to 1000V, with an impulse withstand voltage of 12kV. Even under conditions of short-term withstand at 120kA, the insulation performance is fully guaranteed.

Product protection

The copper busbars are fully tin-plated with a thickness of up to 4 μm , preventing oxidation and enhancing conductivity.



Electrical connections

The GEIS-X busway system connector adopts silver plating treatment with a thickness of 5 μ m, ensuring both prevention of oxidation and electrical connection performance at the joints, enabling the current of the plug-in box to be $\leq 1000A$.



Electrical protection

The GEIS-X busway system utilizes rotating double-break plastic shell circuit breakers as core protective components. With over 20 years of experience in manufacturing and applying double-break MCCBs, GEIS provides reliable electrical protection for customers' distribution lines and equipment. The double-break plastic shell circuit breakers feature strong current-limiting capability, fast breaking speed, and high short-circuit breaking capacity, reducing the impact of electrical faults and effectively protecting customer equipment.



Protection level

The GEIS-X busway system fully considers the safety of personnel and equipment during use, with a straight section protection level up to IP66 and a protection level of up to IP54 with plug-in boxes.

- IP54
 - 5 - Preventing the infiltration of foreign objects and dust.
 - 4 - Preventing water splashing from all directions from entering the electrical appliances and causing damage.
- IP66
 - 6 - Dust tight, completely preventing the infiltration of foreign objects and dust.
 - 6 - Preventing strong water jets.

GEIS-X Busway system

Selection Guide

GEIS-X busway functional unit

GEIS-X	40	34	F3	Protection Level
Product Series	Rated Current	System Type	Functional Unit	blank IP54
GEIS-X Busway system	04 400A	34 3L+N+PE(Enclosure)	F3 Straight section length 3m, without plug interface	66 IP66
	06 630A	35 3L+N+PE(Copper Busbar)	P3 Straight section length 3m, with plug interface	
	08 800A	33 3L+PE(Enclosure)	LH L-shaped Horizontal Bend	
	10 1000A		LV L-shaped Vertical Bend	
	12 1250A		TH T-shaped Horizontal Bend	
	16 1600A		TV T-shaped Vertical Bend	
	20 2000A		ZH Z-shaped Vertical Bend	
	25 2500A		ZV Z-shaped Horizontal Bend	
	32 3200A		TC Variable volume joint	
	40 4000A		EU expansion joint	
	50 5000A		SP Starting Box	
	63 6300A		EC End Cap	
			FE Flange Joint	
		JT Connector		

Selection Example:

Requirements: 4000A, three-phase five-wire system, PE line with copper conductor, without socket, length 3 meters, protection grade IP54; Model: GEIS-X40/35-F3

GEIS-X busway plug-in box

GP	35	R+	N	3	T	400
Product Type	Straight Section System Type	Circuit Breaker Type	Breaking Capacity	Number of Poles	Trip Unit Type	Current Rating
GEIS-X Plug-in box	34 3L+N+PE(Enclosure)	R+ R+series	S 36kA	3 3P	T Thermal magnetic release	016 16A
	35 3L+N+PE(Copper Busbar)	RC+ RC+series	N 50kA	4 4P	
	30 3L+PE(Enclosure)		H 80kA		E electronic release	125 125A
					
						250 250A
					
						400 400A
					
						1000 1000A

GEIS-X Busway system

Technical Data

GEIS-X Technical Data

Rated current of straight section		A	400	630	800	1000	1250	1600	2000	2500	3200	4000	5000	6300
Rated operating voltage	Without Plug-in Unit	V	1000	1000	1000	1000	1000	1000	1000	1000	1000	1000	1000	1000
	With Plug-in Unit	V	690	690	690	690	690	690	690	690	690	690	-	-
Rated insulation voltage	Without Plug-in Unit	kV	1000	1000	1000	1000	1000	1000	1000	1000	1000	1000	1000	1000
	With Plug-in Unit	V	800	800	800	800	800	800	800	800	800	800	-	-
Protection class	Without Plug-in Unit		IP66	IP66	IP66	IP66	IP66	IP66	IP66	IP66	IP66	IP66	IP66	IP66
			IP54	IP54	IP54	IP54	IP54	IP54	IP54	IP54	IP54	IP54	IP54	IP54
	With Plug-in Unit		IP54	IP54	IP54	IP54	IP54	IP54	IP54	IP54	IP54	IP54	-	-
Frequency		Hz	50											
Rated Short-Time Withstand Current	I _{cw}	kA	30	30	30	50	50	85	85	85	85	120	120	120
Rated Peak Short-Circuit Current	I _{pk}	kA	66	66	66	110	110	187	187	187	187	264	264	264
Plug-in Unit Current	Max.	A	200	315	400	500	630	800	1000	1000	1000	1000	-	-
Conductor Resistance														
Resistance	20°C	μΩ/m	0.098	0.086	0.068	0.053	0.038	0.028	0.021	0.016	0.014	0.010	0.008	0.005
Reactance	20°C	μΩ/m	0.035	0.034	0.031	0.021	0.017	0.014	0.011	0.009	0.014	0.006	0.004	0.003
Impedance	20°C	μΩ/m	0.105	0.093	0.076	0.057	0.042	0.032	0.024	0.019	0.016	0.012	0.009	0.006
Grounding Resistance														
Aluminum Alloy Enclosure Grounding	20°C	μΩ/m	46.5	46.5	42.4	37.5	32.4	26.3	21.6	17.6	13.7	11.1	9.1	
50% Independent Grounding	20°C	μΩ/m	148.3	148.3	118.7	91.3	69.8	49.4	37.1	28.3	24.7	18.5	14.1	
Voltage Drop 20°C														
cosØ	1	V/m	0.041	0.056	0.057	0.055	0.051	0.048	0.045	0.043	0.048	0.043	0.042	0.038
cosØ	0.9	V/m	0.043	0.061	0.063	0.059	0.054	0.053	0.051	0.048	0.054	0.051	0.046	0.041
cosØ	0.8	V/m	0.042	0.058	0.061	0.057	0.053	0.052	0.049	0.048	0.054	0.051	0.045	0.041
cosØ	0.7	V/m	0.039	0.055	0.059	0.054	0.051	0.051	0.047	0.046	0.052	0.048	0.043	0.039
cosØ	0.6	V/m	0.036	0.052	0.055	0.051	0.047	0.047	0.044	0.045	0.049	0.046	0.041	0.036
Temperature derating °C														
	45	0.095	400	630	800	1000	1250	1600	2000	2500	3200	4000	5000	6300
	50	0.091	400	630	800	1000	1250	1600	2000	2500	3200	4000	5000	6300
	55	0.085	400	630	800	1000	1250	1600	2000	2500	3200	4000	5000	6300
	60	0.081	400	630	800	1000	1250	1600	2000	2500	3200	4000	5000	6300
	65	0.074	400	630	800	1000	1250	1600	2000	2500	3200	4000	5000	6300
	70	0.067	400	630	800	1000	1250	1600	2000	2500	3200	4000	5000	6300

Functional Units

Straight section

The GEIS-X compact busway's casing is made of a new type of aluminum alloy profile and can offer products with 3L+N+PE (casing). The neutral line is designed with 100% phase line capacity, utilizing the casing as the PE grounding solution. Its equivalent grounding capability exceeds 50% of the phase line capacity. The overall continuous grounding system has low grounding resistance and reliable grounding.

Meanwhile, GEIS-X also considers diverse customer needs by providing a product solution of 3L+N+PE (50% phase line copper busway), meeting the 50% independent grounding option for customers.

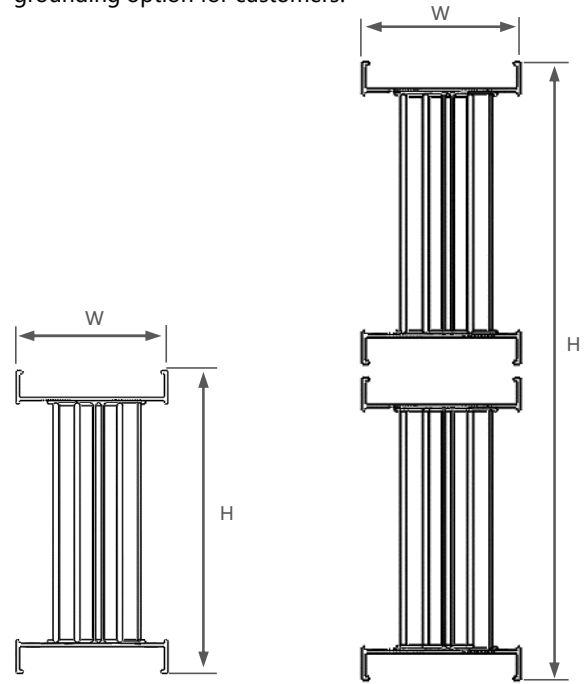
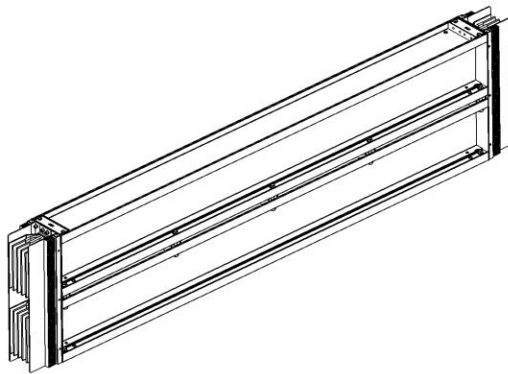

rated current (A)	code	code (with socket)	weight (kg/m)			dimensions(mm)	
			3P3W	3P4W	3P5W	W	H
400	GEIS-XZ04	GEIS-XZC04	13	14	15	135	99
630	GEIS-XZ06	GEIS-XZC06	13	14	15	135	99
800	GEIS-XZ08	GEIS-XZC08	14	17	18	135	109
1000	GEIS-XZ10	GEIS-XZC0	17	20	21	135	124
1250	GEIS-XZ12	GEIS-XZC12	20	24	26	135	144
1600	GEIS-XZ16	GEIS-XZC16	25	31	34	135	179
2000	GEIS-XZ20	GEIS-XZC20	32	39	43	135	219
2500	GEIS-XZ25	GEIS-XZC25	40	50	54	135	269
3200	GEIS-XZ32	GEIS-XZC32	52	63	69	135	380
4000	GEIS-XZ40	GEIS-XZC40	64	80	87	135	460
5000	GEIS-XZ50	GEIS-XZC50	81	95	110	135	560
6300	GEIS-XZ63	GEIS-XZC63	100	115	125	135	630

Functional Units

Form L-vertical bend

rated current (A)	code	standard dimensions (X,Y)mm
400	GEIS-XCZ04	500
630	GEIS-XCZ06	500
800	GEIS-XCZ08	500
1000	GEIS-XCZ10	500
1250	GEIS-XCZ12	500
1600	GEIS-XCZ16	500
2000	GEIS-XCZ20	500
2500	GEIS-XCZ25	500
3200	GEIS-XCZ32	750
4000	GEIS-XCZ40	750
5000	GEIS-XCZ50	750
6300	GEIS-XCZ63	750

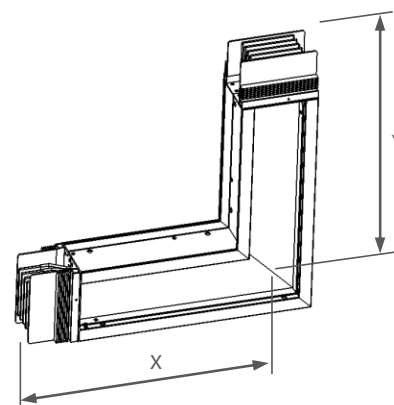

Form L-horizontal bend

rated current (A)	code	standard dimensions (X,Y)mm
400	GEIS-XSP04	500
630	GEIS-XSP06	500
800	GEIS-XSP08	500
1000	GEIS-XSP10	500
1250	GEIS-XSP12	500
1600	GEIS-XSP16	500
2000	GEIS-XSP20	500
2500	GEIS-XSP25	500
3200	GEIS-XSP32	500
4000	GEIS-XSP40	500
5000	GEIS-XSP50	500
6300	GEIS-XSP63	500

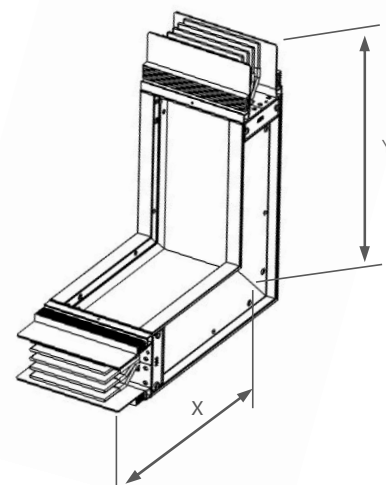

Functional Units

Form T-vertical bend

current (A)	code	standard dimensions (X+Y+Z)mm
400	GEIS-XCT04	500+500+500
630	GEIS-XCT06	500+500+500
800	GEIS-XCT08	500+500+500
1000	GEIS-XCT10	500+500+500
1250	GEIS-XCT12	500+500+500
1600	GEIS-XCT16	500+500+500
2000	GEIS-XCT20	500+500+500
2500	GEIS-XCT25	500+500+500
3200	GEIS-XCT32	750+750+750
4000	GEIS-XCT40	750+750+750
5000	GEIS-XCT50	750+750+750
6300	GEIS-XCT63	750+750+750

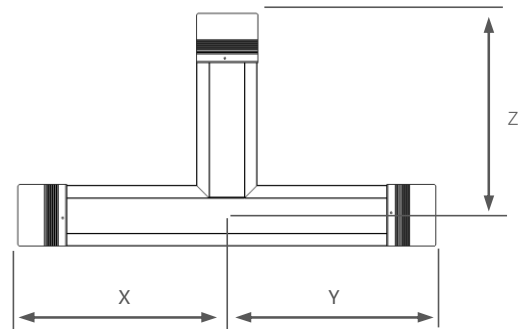

Form T-horizontal bend

current (A)	code	standard dimensions (X+Y+Z)mm
400	GEIS-XST04	500+500+500
630	GEIS-XST06	500+500+500
800	GEIS-XST08	500+500+500
1000	GEIS-XST10	500+500+500
1250	GEIS-XST12	500+500+500
1600	GEIS-XST16	500+500+500
2000	GEIS-XST20	500+500+500
2500	GEIS-XST25	500+500+500
3200	GEIS-XST32	500+500+500
4000	GEIS-XST40	500+500+500
5000	GEIS-XST50	500+500+500
6300	GEIS-XST63	500+500+500

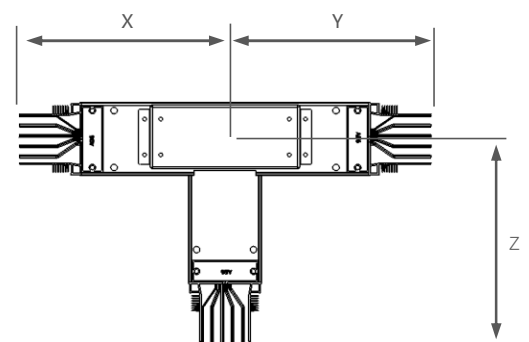

Functional Units

Form Z-vertical bend

current (A)	code	standard dimensions (X+Y+Z)mm
400	GEIS-XZC04	500+500+500
630	GEIS-XZC06	500+500+500
800	GEIS-XZC08	500+500+500
1000	GEIS-XZC10	500+500+500
1250	GEIS-XZC12	500+500+500
1600	GEIS-XZC16	500+500+500
2000	GEIS-XZC20	500+500+500
2500	GEIS-XZC25	500+500+500
3200	GEIS-XZC32	750+750+750
4000	GEIS-XZC40	750+750+750
5000	GEIS-XZC50	750+750+750
6300	GEIS-XZC63	750+750+750

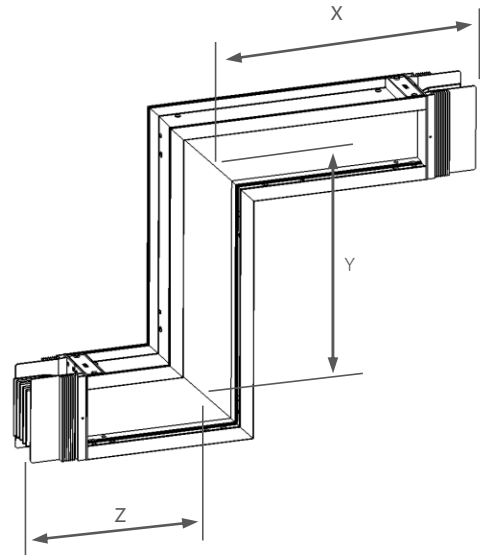

Form Z-horizontal bend

current (A)	code	standard dimensions (X+Y+Z)mm
400	GEIS-XZS04	500+500+500
630	GEIS-XZS06	500+500+500
800	GEIS-XZS08	500+500+500
1000	GEIS-XZS10	500+500+500
1250	GEIS-XZS12	500+500+500
1600	GEIS-XZS16	500+500+500
2000	GEIS-XZS20	500+500+500
2500	GEIS-XZS25	500+500+500
3200	GEIS-XZS32	750+750+750
4000	GEIS-XZS40	750+750+750
5000	GEIS-XZS50	750+750+750
6300	GEIS-XZS63	750+750+750

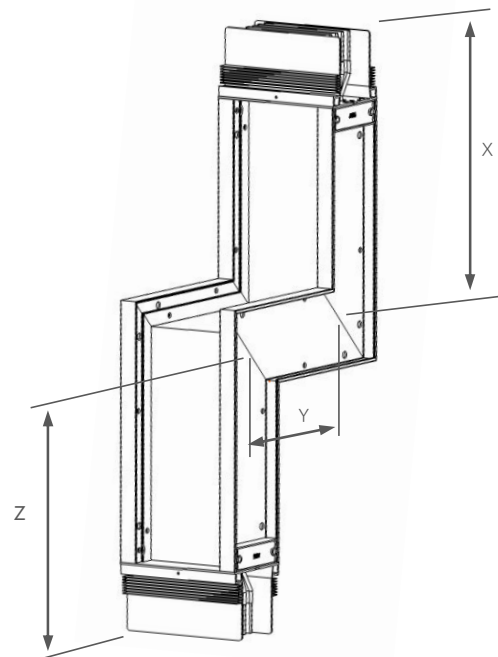

Functional Units

Starting bus bar

The GEIS-X compact busway features a specially designed and convenient starting bus bar structure for easy connections at electrical construction sites.

current (A)	code	X(mm)	Y(mm)	Z(mm)
400	GEIS-XFL04	500	250	100
630	GEIS-XFL06	500	250	100
800	GEIS-XFL08	500	250	100
1000	GEIS-XFL10	500	250	100
1250	GEIS-XFL12	500	250	100
1600	GEIS-XFL16	500	250	125
2000	GEIS-XFL20	500	250	125
2500	GEIS-XFL25	500	250	125
3200	GEIS-XFL32	500	250	150
4000	GEIS-XFL40	500	250	150
5000	GEIS-XFL50	500	250	150
6300	GEIS-XFL63	500	250	150

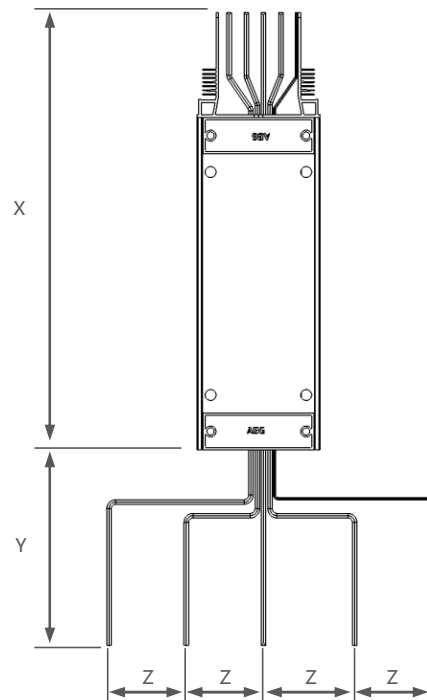

copper bar width	hole pitch	slot hole
30	20*40	Ø13
40	20*40	Ø13
50	25x25	Ø9
60	30x30	Ø11
80	40x40	Ø13
100	50x50	Ø17
120	60x60	Ø21
125	65x65	Ø21

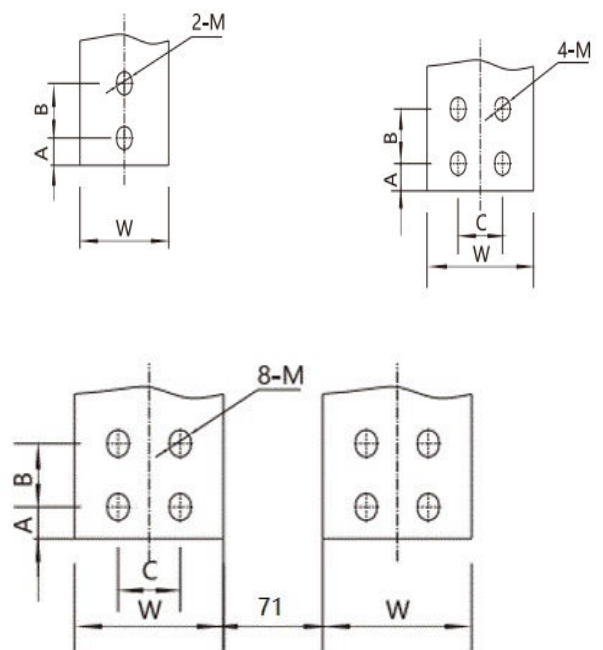

double-layer busway

Functional Units

Starting flange

Rated current (A)	H (mm)	A (mm)	B (mm)	C (mm)
400	99	442	81.5	0
630	99	442	81.5	0
800	109	442	86.5	0
1000	124	442	94	0
1250	144	442	104	0
1600	179	442	121.5	0
2000	219	442	141.5	0
2500	269	442	166.5	0
3200	380	442	222	0
4000	460	442	262	0
5000	560	442	312	0
6300	630	442	347	0

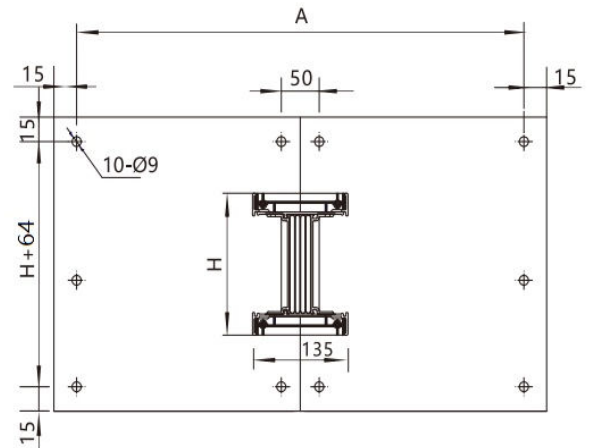
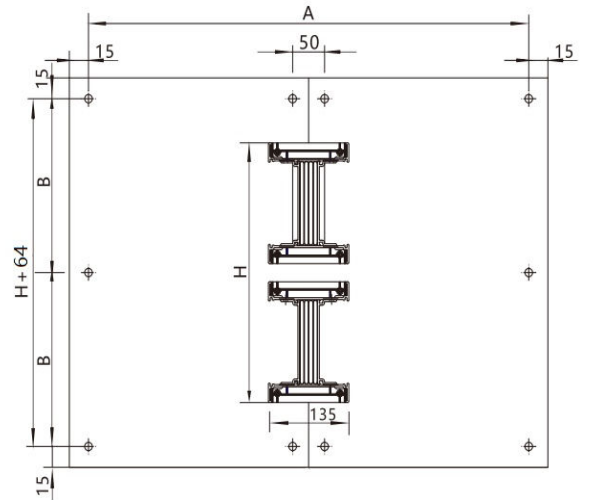

Starting box

The starter box is an enclosed casing that connects the busway's beginning or end with on-site low-voltage cabinets or transformers. Its size is determined by on-site measurements and can also be customized according to drawings or user requirements.

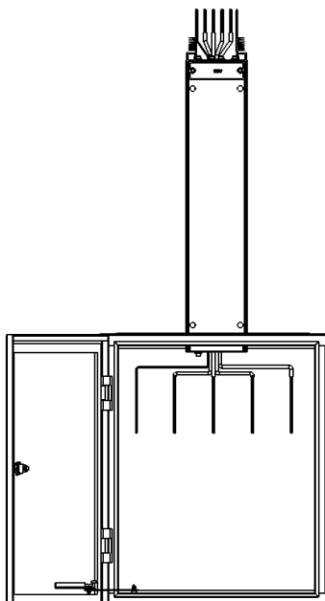

starter box with flange joint

Functional Units

Flexible connection

current rating	L	W	A	B	C	T
(A)	(mm)					
400	500	30	15	0	40	4
630	500	30	15	0	40	10
800	500	40	15	0	40	10
1000	500	50	15	12	12	10
1250	500	60	15	15	15	10
2000	500	80	20	40	40	10
2500	500	125	30	65	65	10
3200	500	120	30	60	60	10
4000	500	125	30	65	65	10
5000	500	125	30	65	65	10
6300	500	125	30	65	65	10

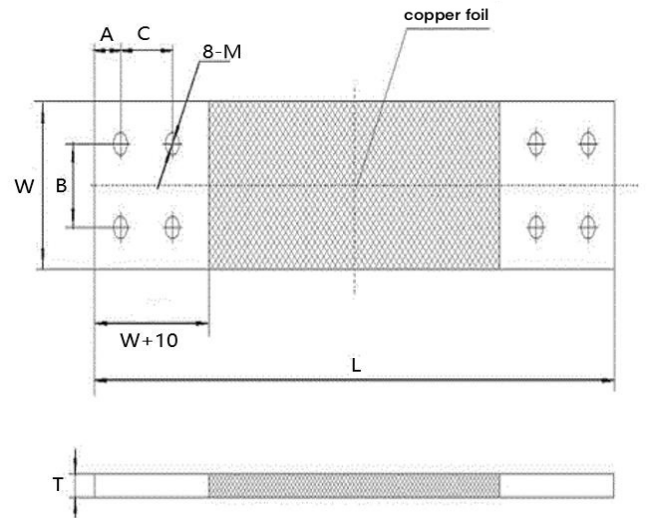

Expansion joint

In complex working conditions, when busway are used, the length changes caused by thermal expansion and contraction due to environmental temperature changes or when crossing wall expansion joints can be compensated by installing expansion bus duct joints. The expansion range is $\pm 25\text{mm}$, and an expansion joint should be installed every 60 meters along the straight distance.

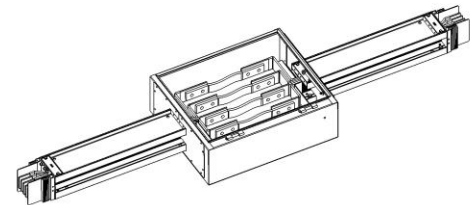

Compensating joint

In engineering, to achieve a more economical power distribution method, compensating joints can be installed to facilitate the transition of current from large to small.

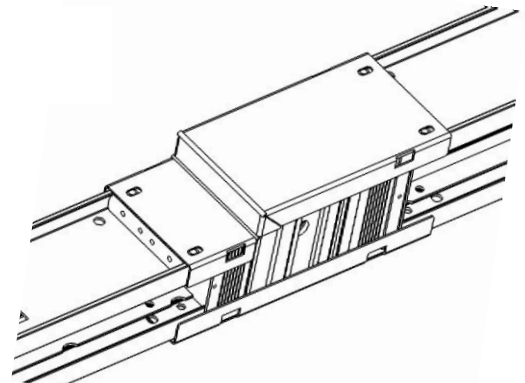

Plug-in Boxes

Plug-in box

The design of the plug-in box facilitates flexible distribution of electrical power to loads. By coordinating with specialized connectors for compact bus ducts, it enables quick power access and reserves provisions for future load demands.

The plug-in box is equipped with a mechanical interlocking device that prevents insertion and removal operations when the circuit is closed. This ensures the electrical safety of both the plug-in box and the bus duct itself, as well as the personal safety of the operators.

The configured molded case circuit breaker can be selected based on the distribution system type of the straight section and the needs of the user.

- Diverse circuit breaker options, R+ or RC+ series
- Short-circuit breaking capacity of 36/50/80kA
- 3-pole or 4-pole protection
- Thermal-magnetic or electronic protection, grounding, leakage protection, etc

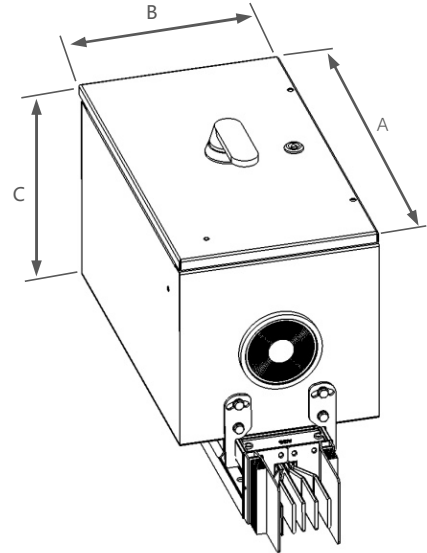

current rating (A)	enclosure dimensions (height*width*depth)mm A*B*C
16A-160A	410*250*310
180A-350A	520*300*310
400A-630A	820*370*350
800A-1000A	1200*430*350

Plug-in Boxes

R+ molded case circuit breaker

The R+ series circuit breakers have evolved into a protection device that integrates aesthetics and technology, used for low-voltage distribution and control applications. The circuit breakers are available in three sizes, each conforming to the requirements associated with their applications.

The R+ molded case circuit breakers are used for protection, isolation, and switching circuits in low-voltage distribution networks. They combine devices with unique current-limiting characteristics and integrated protection units known as trip units to protect circuits. The trip units are used to protect circuits and/or electromechanical or electronic devices connected to these circuits. Electromechanical thermal-magnetic trip units offer various protection modes, such as thermal-magnetic with overload and short circuit protection, or purely magnetic for short circuit protection. Electronic trip units provide a wide range of settings, with multiple types offering more precise and comprehensive protection. Each trip unit's parameter setting area is covered with a sealable transparent plastic panel.

The breakthrough design of the R+ MCCB lies in its rotary double contacts, which allow the device to achieve the highest current rating in the smallest size. When the circuit breaker operates, it does so at twice the speed and force of traditional circuit breakers, thus providing exceptional current-limiting capabilities. This reduces the peak current and power values in the circuit, lowering the electrical and thermal stresses on the protected cables, downstream circuit breakers, and devices.



By implementing backup protection to limit electromechanical and thermal stresses, the protective devices installed downstream of the R+ circuit breaker must withstand the thermal effects and electromechanical forces generated at their installation points. Installing a current-limiting circuit breaker upstream limits these values, allowing for the use of smaller and more economical protective devices compared to situations without current limitation.

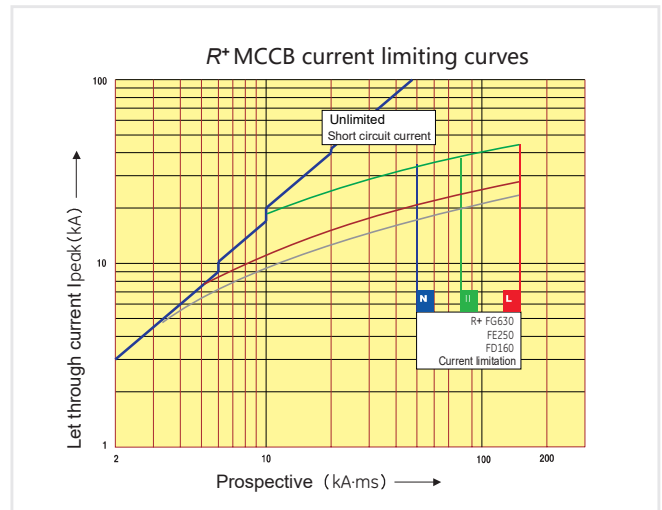
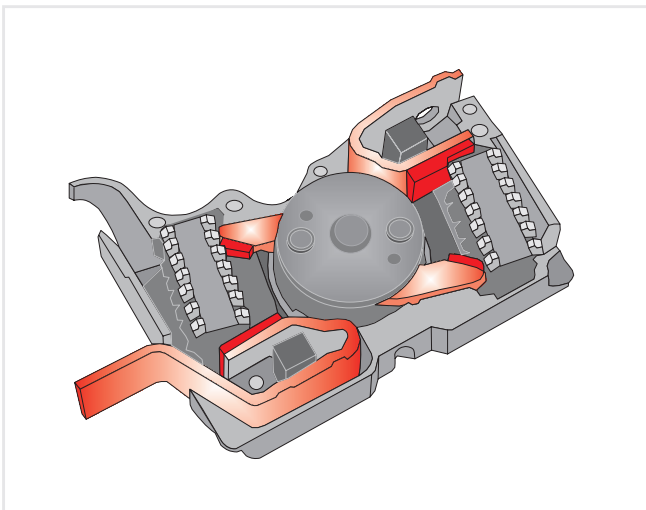

Plug-in Boxes

The R+ thermal-magnetic trip unit.

The R+ circuit breaker can isolate and switch low-voltage distribution circuits, protecting the cables and equipment within the circuit. These typical thermal-magnetic devices provide overload (thermal) protection and short-circuit (magnetic) protection. The trip unit is designed with the user in mind, and its rating is usually calibrated in amperes. To prevent unauthorized adjustments to the breaker settings, the trip unit includes a transparent, tamper-resistant seal cover. The unit comes in 3-pole and 4-pole configurations and offers various subtypes determined by the application. Thermal protection devices are typically calibrated at an ambient temperature of 40 degrees Celsius, with versions also available for calibration at 55 degrees Celsius.



Field-adjustable thermal-magnetic protection device

Even with thermal-magnetic protection, the R+ molded case circuit breaker allows for convenient adjustment of the breaker's overload and short-circuit protection settings via the adjustment knob located on the front of the trip unit.

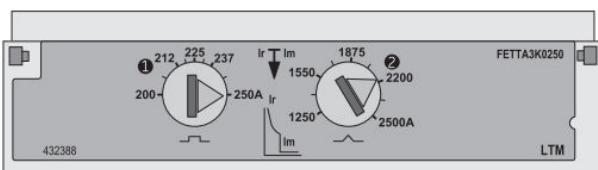
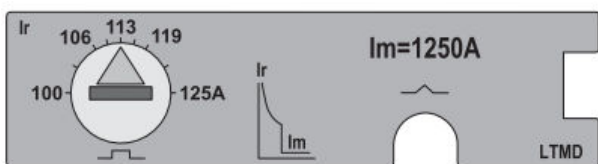

Fault type indication device.

The device current range available is from 3 to 250A, as a three-pole or four-pole device. The high-performance thermal-magnetic trip units come in selective and non-selective types, equipped with a fault indicator that conforms to HD384 and can distinguish between overload and short-circuit events. This patented safety feature allows users to manually reset the circuit breaker directly after an overload event to minimize downtime.

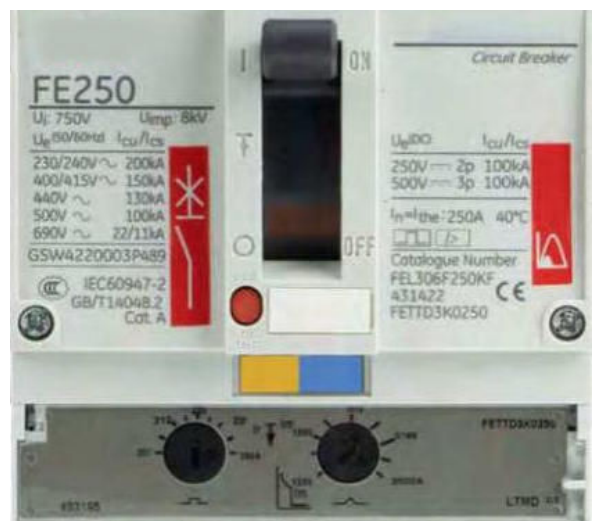

Plug-in Boxes

R+ electronic trip unit

Simple Elegant

The PremEonS series of new-generation electronic trip units offer high stability and reliability, suitable for low-voltage distribution networks in various harsh environments. The PremEonS series electronic trip units are based on 32-bit processor technology, providing comprehensive protection features to meet the demands of low-voltage distribution networks.

The design features a simple dial setting method, offering a wide range of adjustable rated current values from 0.4 to 1In.



PremEon S

Each standard unit includes multiple adjustable overcurrent protection setting knobs. The overload long-time delay protection setting (LT) ranges from 0.4 to 1 In (the rated current of the electronic trip unit), with 16 adjustable steps marked with actual current values on the setting knob. The short-circuit short-time delay protection setting (ST) ranges from 1.5 to 10Ir (Ir being the LT setting value), and this function can be turned off (adjustment knob set to OFF); short-circuit short-time delay setting Tsd, when I²t is set to OFF it defaults to a fixed short-circuit short-time delay of 0~0.4s, and when I²t is set to ON, it becomes an inverse time short-circuit short-time delay of 0.1~0.4s, with four adjustable levels for each. Standard electronic protection units have a fixed value for short-circuit instantaneous protection, whereas high-performance electronic protection units allow adjustment of the instantaneous protection value. Short-circuit instantaneous protection also features selective protection, determined by waveform capture and recognition to ensure coordination with downstream circuit breakers. Optional ground fault protection features are available, with ground fault protection settings ranging from 0.2 to 1 In and protection delay times adjustable by dial, offering fixed-time limit protection or I²T inverse time limit protection. All specifications of electronic trip units are equipped with LED indicators.

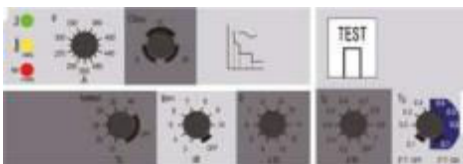
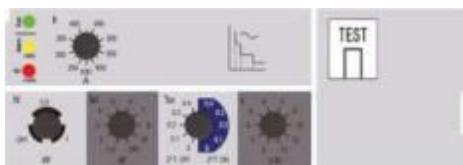

Plug-in Boxes

Universal accessories

Safe, easy to install

The internal accessories are designed for easy installation and safety. When the circuit breaker panel is removed, it automatically trips and remains tripped until the panel is reinstalled. Removing the panel provides access to specially designed insulated compartments where accessories can be safely and easily installed in marked areas. This personalized design also includes wiring channels for external connections, allowing access to internal terminals for easier accessory connections. These terminals are meticulously designed to accommodate wire sizes ranging from 0.5 to 2.5mm².

The same internal accessories are used across FD, FE, and FG frame specifications. The installation system and wiring method are both simple and effective. For plug-in and withdrawable circuit breakers, an 8-pole plug/socket combination can be used. These combinations feature wiring with special openings that can pass through the back of the circuit breaker.

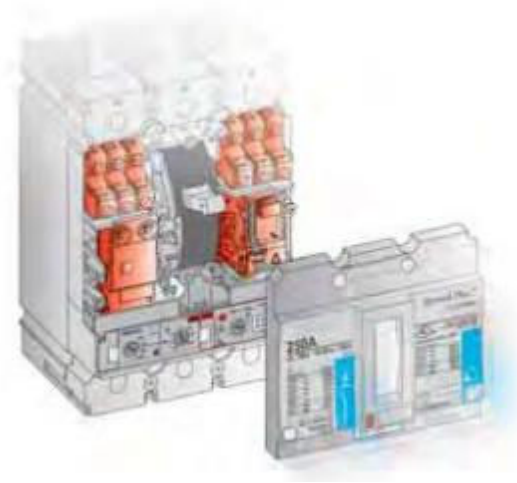

Auxiliary contacts and alarm contacts

The internal accessories are universal for FD, FE, and FG frame molded case circuit breakers in the R+ series. They offer a novel, patented auxiliary contact module with both normally closed and normally open contacts, suitable for high-current applications. Selective alarm contacts with basic contact features are also available.

Trip coil

The shunt and undervoltage trip coils are a newly designed type of trip coil that combines the advantages of both electromechanical and electronic functions. Most trip coils are universal for both AC and DC voltages and feature a wide voltage range. They incorporate all the characteristics of the internal accessories for R+ series molded case circuit breakers, such as low power consumption, contactless operation, locking design, and ease of use.

Installation

Busway connection diagram

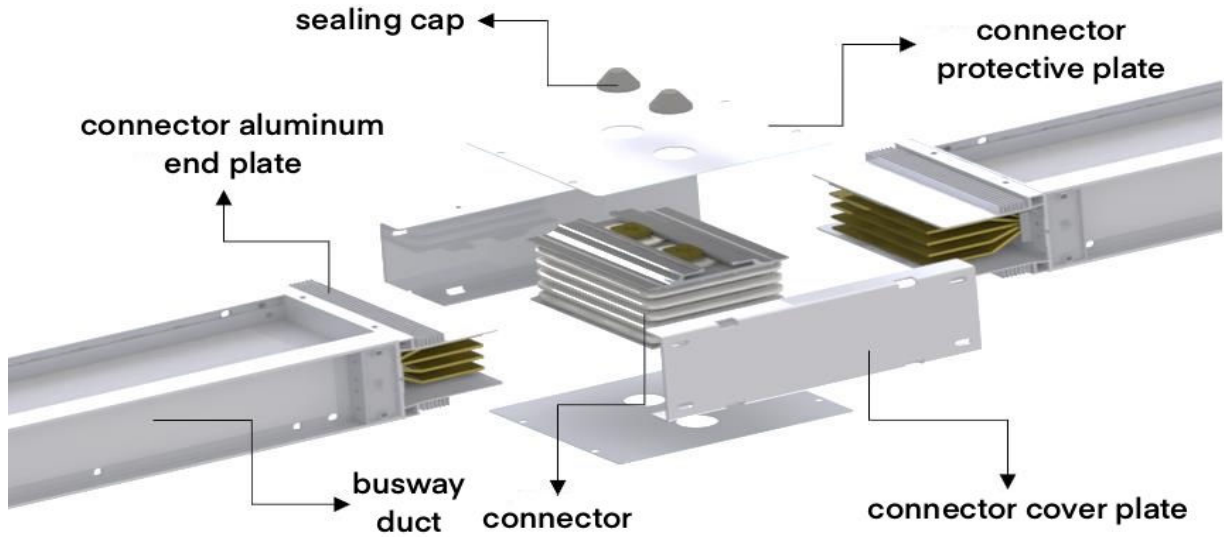

Installation accessories

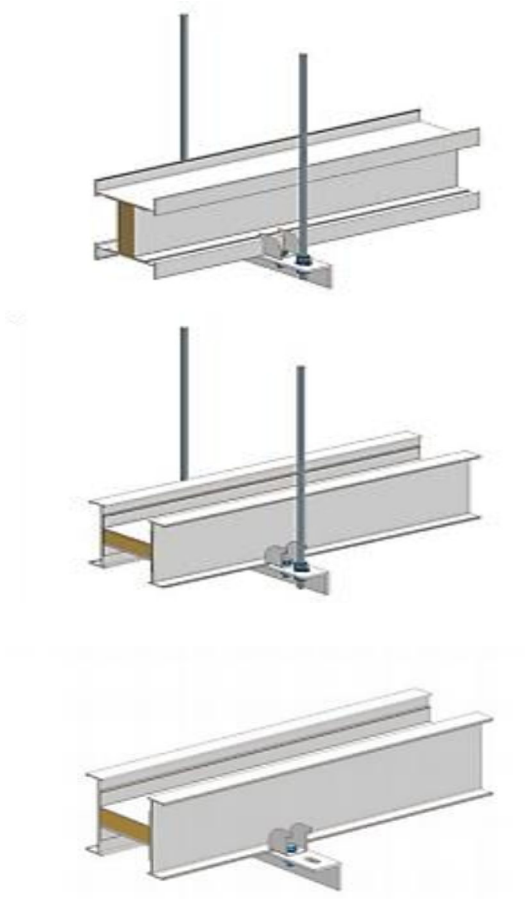

Busway Trunking System	name	code	installation method
GEIS-X04-25	M12all-thread hanger	GEIS-XDJ12	vertical
GEIS-X32-63	M16all-thread hanger	GEIS-XDJ16	vertical
GEIS-X04-25	M12all-thread hanger	GEIS-XDJ12	horizontal
GEIS-X32-63	M16all-thread hanger	GEIS-XDJ16	horizontal
GEIS-X04-63	arm support bracket	GEIS-XTB	vertical/horizontal
GEIS-X04-63	pressure plate	GEIS-XYB	vertical/horizontal

Installation

Installation accessories

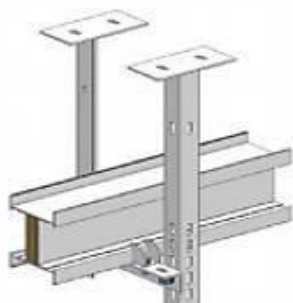
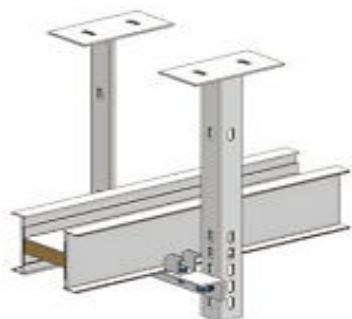

Busbar Trunking System	name	code	installation method
GEIS-X04-25	5#Angle Steel Bracket Arm	GEIS-XDJ50	Horizontal
GEIS-X32-63	5#Angle Steel Bracket Arm	GEIS-XDJ50	Horizontal
GEIS-X04-25	5#Angle Steel Bracket Arm	GEIS-XDJ50	Vertical
GEIS-X32-63	5#Angle Steel Bracket Arm	GEIS-XDJ50	Vertical

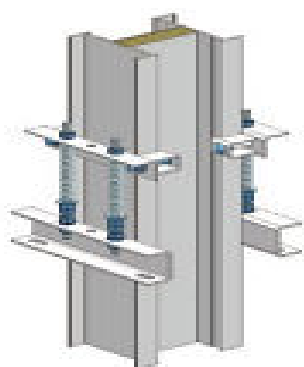

Busbar Trunking System	name	code	installation method
GEIS-X04-12	Spring Bracket - Single Spring	GEIS-XTH1	Vertical
GEIS-X16-25	Spring Bracket - Double Spring	GEIS-XTH2	Vertical
GEIS-X32-63	Spring Bracket - Triple Spring	GEIS-XTH3	Vertical
GEIS-X04-63	Vertical Fixed Bracket	GEIS-XGD	Vertical

Installation

Vertical installation

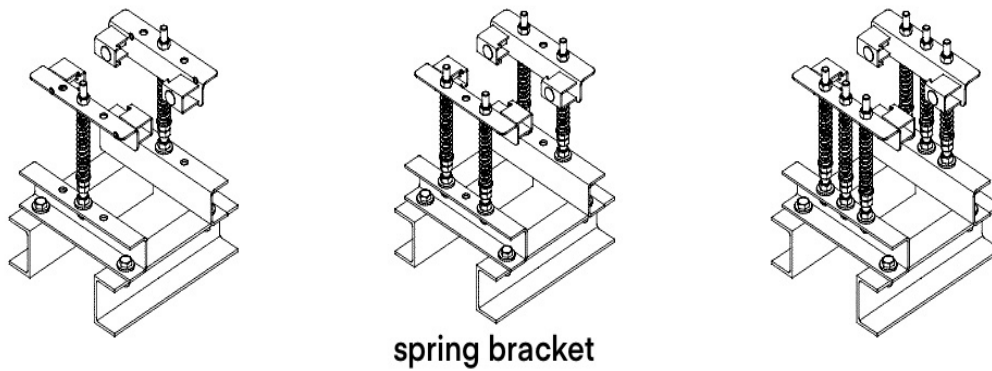
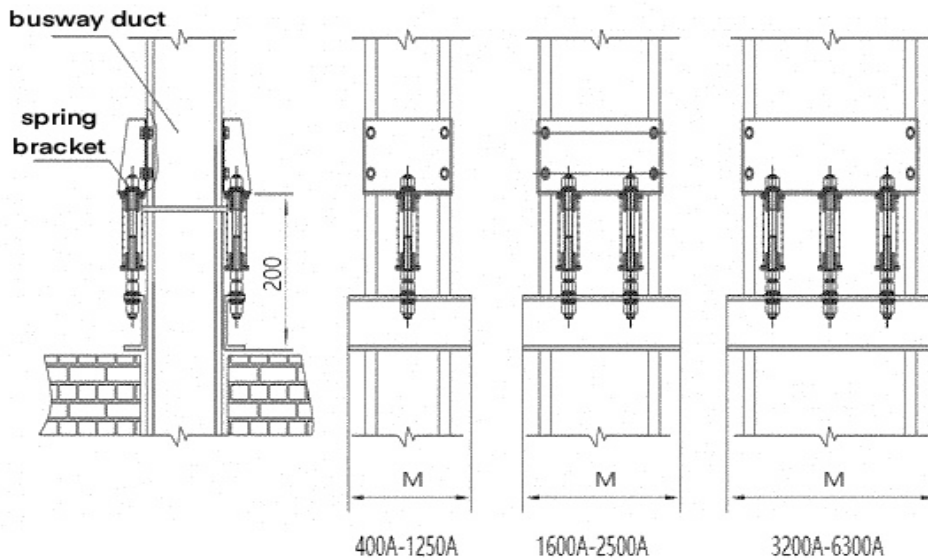

Rated current (A)	Code	M(mm)
400	GEIS-XTH04-200	200
630	GEIS-XTH06-200	200
800	GEIS-XTH08-250	250
1000	GEIS-XTH10-250	250
1250	GEIS-XTH12-250	250
1600	GEIS-XTH16-300	300
2000	GEIS-XTH20-320	320
2500	GEIS-XTH25-370	370
3200	GEIS-XTH32-480	480
4000	GEIS-XTH40-560	560
5000	GEIS-XTH50-660	660
6300	GEIS-XTH63-730	730

Installation

Horizontal support arm installation

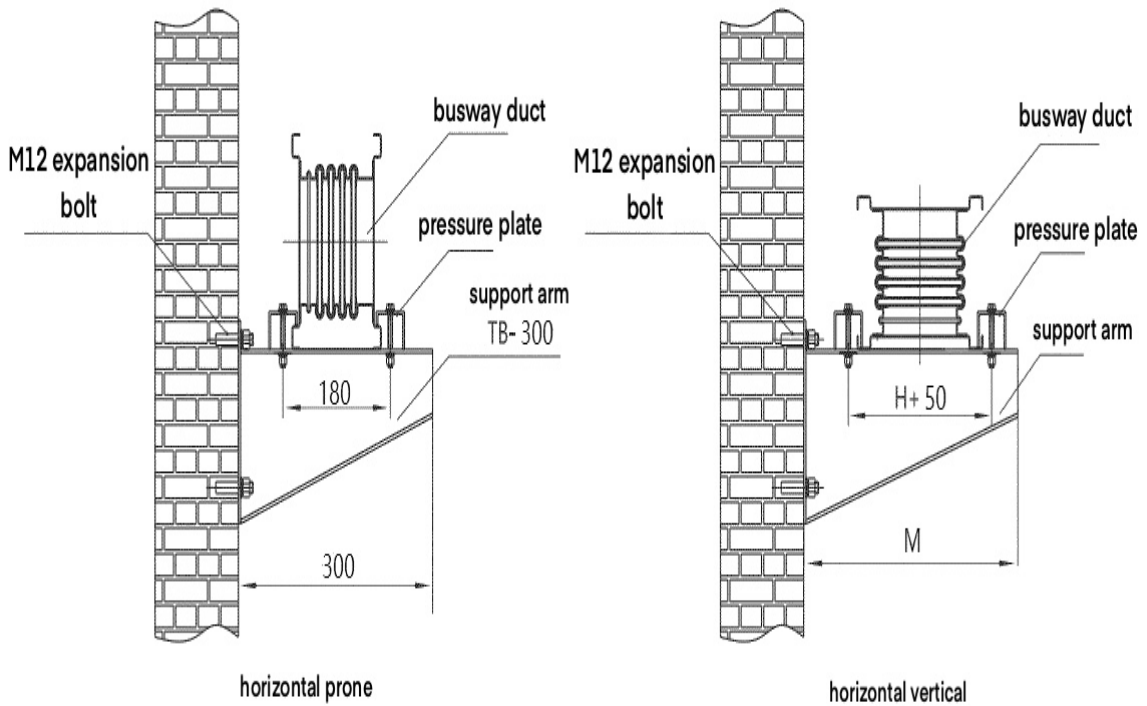

Rated current (A)	Code	H(mm)	L(mm)
400	GEIS-XTB04-200	99	200
630	GEIS-XTB06-200	99	200
800	GEIS-XTB08-250	109	250
1000	GEIS-XTB10-300	124	300
1250	GEIS-XTB12-300	144	300
1600	GEIS-XTB16-350	179	350
2000	GEIS-XTB20-350	219	350
2500	GEIS-XTB25-550	269	550
3200	GEIS-XTB32-600	380	600
4000	GEIS-XTB40-650	460	650
5000	GEIS-XTB50-700	560	700
6300	GEIS-XTB63-750	630	750

Installation

Horizontal hanger installation

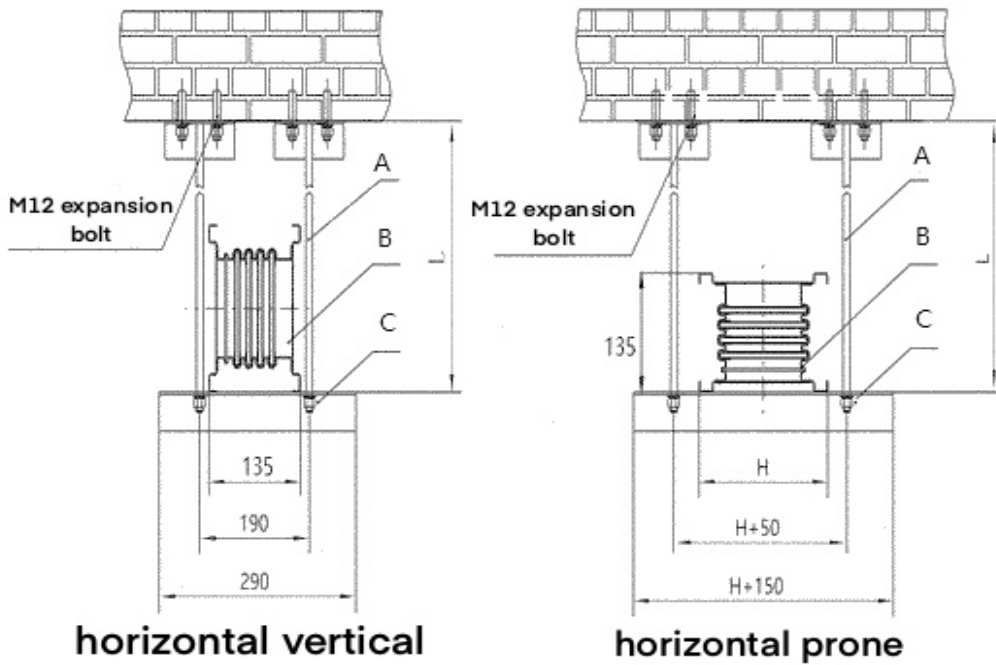

Note: A* threaded hanger, B* busway trunking, C* crossarm

Rated current (A)	Code	H(mm)	L(M)
400	GEIS-XDJ04-12	99	M12 theaded rod, not exceeding 5 meters
630	GEIS-XDJ06-12	99	
800	GEIS-XDJ08-12	109	
1000	GEIS-XDJ10-12	124	
1250	GEIS-XDJ12-12	144	
1600	GEIS-XDJ16-12	179	
2000	GEIS-XDJ20-12	219	
2500	GEIS-XDJ25-12	269	M12 theaded rod, not exceeding 5 meters
3200	GEIS-XDJ32-16	380	
4000	GEIS-XDJ40-16	460	
5000	GEIS-XDJ50-16	560	
6300	GEIS-XDJ63-16	630	

GEIS

GEIS Electric

Website: www.geis.tech

Hotline: +86 400-820-5234

This catalog may be subjected to revision without prior notice. Version No.: GENCLVBR25V2

